

PR Series Process Control Card PC201 User Guide

Warning Symbol



The Symbol calls attention to an operating procedure, practice, or the like, which, if not correctly performed or adhered to, could result in personal injury or damage to or destruction of part or all of the product and system. Do not proceed beyond a warning symbol until the indicated conditions are fully understood and met.

Preface

Original equipment manufacturer reserves the right to change information available in this document without notice. Manufacturer is not liable for any damages incurred to equipment/personal during installation or use of equipment as explained in this document. User must acquire sufficient knowledge & skills prior to use the equipment in the application and follow all the local standards & regulations to meet safety requirements

Copyright

The documentation and the software included with this product are copyrighted 2016 By Brainchild Electronic Co. Ltd. All rights are reserved. Brainchild Electronic Co., Ltd. reserves the right to make improvements in the products described in this manual at any time without notice.

No part of this manual may be reproduced/ copied/ translated or transmitted in any form or by any means without the prior written permission of Brainchild Electronic Co.,Ltd. The information we supply is believed to be accurate and reliable as of this printing. However, we assume no responsibility for its use.

Contact Information

Head Office & Factory

Brainchild Electronic Co. Ltd.

209 Chongyang Road, Nangang Dist.,

Taipei 11573, Taiwan

Tel: +886-2-2786-1299 Fax: +886-2-2786-1395

Website: www.brainchild.com.tw

Email: sales@brainchild.com.tw; service@brainchild.com.tw

China Sales Office

Brainchild Electronic (Kunshan) Co. Ltd.

Room 405, Building #6, Huamin Gentlefolk Garden

No. 13, Qianjin Central Road, Kunshan City, Jiangsu 215300, China

Tel: +86-512-5511-6133 Fax: +86-512-5511-6113

Website: www.brainchild.com.cn

Email: sales@brainchild.com.cn;

service@brainchild.com.cn

TABLE OF CONTENTS

1	INTRODUCTION	8
1.1	INTRODUCTION	8
1.2	FEATURES	8
1.3	PROCESS CONTROL CARD	9
1.3.1	<i>Flexible Configuration of Program</i>	11
1.3.2	<i>Maximum Capacity of Program</i>	11
1.3.3	<i>Event Input</i>	11
1.3.4	<i>Programmable Event Outputs</i>	11
1.3.5	<i>High Accuracy</i>	11
1.3.6	<i>Fast Sampling Rate</i>	11
1.3.7	<i>Fuzzy Control</i>	12
1.3.8	<i>Auto-tuning</i>	12
1.3.9	<i>Lockout Protection</i>	12
1.3.10	<i>Bumpless Transfer</i>	12
1.3.11	<i>Digital Filter</i>	12
1.3.12	<i>Soft-start Ramp</i>	12
1.3.13	<i>Pump Control</i>	12
1.4	EXPANSION I/O MODULES FOR PID	12
1.4.1	<i>PID Control Module</i>	12
1.5	SMART MECHANISM	13
1.6	PROCESS CONTROL CARD PC201 ORDERING CODE	13
1.7	SPECIFICATION	14
1.7.1	<i>Input1</i>	14
1.7.2	<i>Input2</i>	15
1.7.3	<i>Input3 (Event Input)</i>	16
1.7.4	<i>Output1/Output2</i>	16
1.7.5	<i>Alarm 1/ Alarm 2</i>	17
1.7.6	<i>Control Mode</i>	17
1.7.7	<i>Digital Filter</i>	18
2	INSTALLATION AND WIRING	19
2.1	UNPACKING	19
2.2	INPUT OUTPUT WIRING CONNECTION	20
2.2.1	<i>Wiring Precautions</i>	20
2.2.2	<i>PID Control Module</i>	20
3	PROCESS CONTROL CARD FEATURES	22
3.1	CONFIGURATION	22
3.2	CONTROLLER	22
3.3	RAMP & DWELL FUNCTION	22
3.4	ON FIELD CALIBRATION	22
4	PROCESS CONTROL CARD FUNCTIONS	23
4.1	MENUS	23
4.2	STATUS BAR	32

4.3	PROCESS CONTROL CARD CONFIGURATION -----	33
4.3.1	<i>Process Control Card Configuration</i> -----	34
4.3.1.1	Controller -----	35
4.3.1.1.1	Name -----	36
4.3.1.1.2	Parameter -----	36
4.3.1.1.3	Channel -----	72
4.3.1.1.4	Sample Configuration of Process Control Card -----	76
4.3.1.1.4.1	Heat Only ON-OFF Control -----	76
4.3.1.1.4.2	Cool Only ON-OFF Control -----	78
4.3.1.1.4.3	Heat Cool Control -----	78
4.3.1.1.4.4	Heater Break Alarm -----	80
4.3.1.1.4.5	Loop Break Alarm -----	81
4.3.1.1.4.6	Sensor Break Alarm -----	81
4.3.1.1.4.7	Failure Transfer -----	82
4.3.1.1.4.8	Bumpless Transfer -----	83
4.3.1.1.4.9	PV1 Shift -----	84
4.3.1.1.4.10	SP1 Range -----	85
4.3.1.1.4.11	Dwell Timer -----	85
4.3.1.1.4.12	Process Alarms -----	86
4.3.1.1.4.13	Deviation Alarm -----	88
4.3.1.1.4.14	Deviation Band Alarm -----	90
4.3.1.1.4.15	Event Input -----	91
4.3.1.1.4.16	Second Set Point -----	93
4.3.1.1.4.17	Second PID Set -----	93
4.3.1.1.4.18	Ramp & Dwell -----	94
4.3.1.1.4.19	Remote Set Point -----	96
4.3.1.1.4.20	Differential Control -----	97
4.3.1.1.4.21	Output Power Limit -----	98
4.3.1.1.4.22	Digital Filter -----	98
4.3.1.1.4.23	Auto-Tuning and Manual Tuning -----	99
4.3.1.2	Ramp & Dwell(Profile) -----	102
4.3.1.2.1	Ramp & Dwell: -----	103
4.3.1.2.2	Segments: -----	104
4.3.1.2.2.1	Ramp Segment Parameters: -----	105
4.3.1.2.2.2	Dwell Segment Parameters: -----	108
4.3.1.2.2.3	Go Back Segment Parameters: -----	108
4.3.1.2.2.4	End Segment Parameters: -----	108
4.3.1.2.2.5	Time to Target Segment Parameters: -----	109
4.3.1.2.3	Start/End Jobs -----	109
4.3.1.2.4	Start/Stop Profile(Ramp &Dwell) -----	109
4.4	DISPLAY -----	111
5	APPLICATION -----	112
5.1	OVEN CONTROL WITH ZONE TEMPERATURE RECORDING -----	112

Table of Figures

Figure 1-1.Fuzzy PID System Block Diagram	9
Figure 1-2.PID System Stability with and without Fuzzy.....	10
Figure 2-1.Process Control Card Wiring Diagram	21
Figure 3-1.Configuration Layout	22
Figure 4-1.Home Screen.....	23
Figure 4-2.Menu Screen.....	24
Figure 4-3.Real Time Menu	24
Figure 4-4.Overview Display	25
Figure 4-5.PID Controller Module Display	25
Figure 4-6.Display Modes	26
Figure 4-7.Real Time Alarms	26
Figure 4-8.Historical Data Screen	27
Figure 4-9.Event History	28
Figure 4-10.Report Screen	29
Figure 4-11.More Menu.....	29
Figure 4-12.Operate Menu.....	30
Figure 4-13.Configuration Layout	31
Figure 4-14.More Menu.....	32
Figure 4-15.Status Bar During Logging	32
Figure 4-16.Status Bar During Logging Stopped.....	32
Figure 4-17.Status Bar during Logging with Batch function	32
Figure 4-18.Status Bar During Logging Stopped with Batch Function	32
Figure 4-19.Tree Type Configuration Layout	33
Figure 4-20.Process Control Card Channel Configuration	35
Figure 4-21.Process Control Card Channel Configuration	36
Figure 4-22.Process Control Card Configuration Window.....	37
Figure 4-23.Process Control Card Configuration Window for Read only Parameter	37
Figure 4-24.Process Control Card Channel Configuration	72
Figure 4-25.Log Speed	74
Figure 4-26.Events with Job	74
Figure 4-27. Event Configuration Example	76
Figure 4-28.Heat Only ON-OFF Control	77
Figure 4-29.Cool Only ON-OFF Control.....	78
Figure 4-30. Heater Break Alarm	80
Figure 4-31.Without Bumpless Transfer.....	83
Figure 4-32. With Bumpless Transfer.....	84
Figure 4-33.PV1 SHIFT Application.....	85
Figure 4-34.SP1 Range	85
Figure 4-35.Dwell Timer.....	86
Figure 4-36.Normal Process Alarm	87
Figure 4-37.Latching Process Alarm	87
Figure 4-38.Holding Process Alarm	88
Figure 4-39.Latching / Holding Process Alarm	88
Figure 4-40.Normal Deviation Alarm	89
Figure 4-41.Latching Deviation Alarm.....	89
Figure 4-42.Holding Deviation Alarm.....	89
Figure 4-43.Latching/Holding Deviation Alarm.....	90
Figure 4-44.Normal Deviation Band Alarm.....	90
Figure 4-45.Latching Deviation Band Alarm	91
Figure 4-46.Holding Deviation Band Alarm	91

Figure 4-47.Latching/Holding Deviation Band Alarm	91
Figure 4-48.Ramp Function	94
Figure 4-49.Dwell Timer.....	95
Figure 4-50.Ramp Accompanied with Dwell Timer	96
Figure 4-51.Relationship Between PV1 & PV2 for Differential Control.....	97
Figure 4-52.Power Limit Function.....	98
Figure 4-53.Filter Characteristics	99
Figure 4-54.Process Control Module Real time.....	100
Figure 4-55.Auto-Tuning	100
Figure 4-56.Auto-Tuning In progress.....	101
Figure 4-57.Manual Tuning In Progress.....	101
Figure 4-58.Ramp & Dwell Configuration Window	102
Figure 4-59.Set Point Profile	103
Figure 4-60.Ramp Segment	105
Figure 4-61.Hold Back on Dwell.....	107
Figure 4-62.Hold Back on Positive Ramp	107
Figure 4-63.Hold Back Negative Ramp	107
Figure 4-64.Dwell Segment	108
Figure 4-65.Go Back Segment.....	108
Figure 4-66.End Segment	108
Figure 4-67.Time To Target Segment	109
Figure 4-68.Profile Start/End Job.....	109
Figure 4-69.Run Profile	110
Figure 4-70.Profile Running.....	110
Figure 5-1.Oven Control with Zone Temperature Recording	112
Figure 5-2. Oven Control with Zone Temperature Recording System.....	113

Table of Tables

Table 1-1. Input 1 Characteristics	15
Table 1-2. Input 2 Characteristics	16
Table 1-3. Output Characteristics	16
Table 1-4. SSR Output Characteristics	17
Table 2-1.Environmental Specification	19
Table 4-1.PID Parameter List.....	47
Table 4-2.Process Control Card Input Range	48
Table 4-3.Range of A1SP	48
Table 4-4.Range of A2SP	48
Table 4-5.Range Of SP2.....	48
Table 4-6.Mode Selection	49
Table 4-7.Communication Mode	49
Table 4-8.Communication Protocol	50
Table 4-9.Communication Baud Rate	50
Table 4-10.Communication Data Length	51
Table 4-11.Communication Parity	51
Table 4-12.Communication Stop Bit	51
Table 4-13 Function of AOFN	52
Table 4-14 Selection of IN1 Type	53
Table 4-15.Display Unit for IN1 & IN2	53
Table 4-16.Decimal Digit for DP1&DP2	53
Table 4-17.IN2 Input.....	54
Table 4-18.EIFN Function	55
Table 4-19.OUT1 Action.....	55
Table 4-20.OUT1 & OUT2 Type.....	55
Table 4-21.OUT2 Function	56
Table 4-22.Display Function	56
Table 4-23. Alarm1 & Alarm 2 Function	57
Table 4-24.Alarm1 & Alarm2 Operation Mode.....	57
Table 4-25.Alarm1 & Alarm2 Failure Transfer Mode.....	58
Table 4-26.Auto Tuning	58
Table 4-27.Sleep Mode	58
Table 4-28.PV Mode Selection	59
Table 4-29.SP2 Set Point Format	59
Table 4-30 Filter Damping Time Constant of PV	59
Table 4-31 Set Point Mode Selection	60
Table 4-32 SEL Selection	61
Table 4-33 Default File Selection	61
Table 4-34.Error Codes and Corrective Actions.....	68
Table 4-35 PROG CODE	69
Table 4-36 Mode	70
Table 4-37.Unit Determination for A1SP,A1DV,A1HY	70
Table 4-38.Unit Determination for A2SP,A2DV,A2HY	71
Table 4-39.RAMP Unit	71
Table 4-40 .Unit Determination of AOLO & AOHI	71
Table 4-41.Heat Cool Control Modes	79

1 Introduction

1.1 Introduction

Generally most of the furnace applications require Controller and Recorder separately to control and record the data. Some Furnaces application requires Ramp & Dwell controllers .The new generation Paperless Recorder provides PID Control, Ramp & Dwell Control and Recording in one device by using the new process control Card PC201 . This is a **single loop controller** for Furnace applications. This will reduce Cost ,Space ,Wiring required for using controller and Recorder separately.

1.2 Features

The Process Control Card has lot of unique Features on its hardware and Software. The unique Features are listed below.

- ❖ PID Controller, Ramp & Dwell Controller and Recorder 3 in one Device
- ❖ Plug and Play I/O Options
- ❖ 18-bit Universal input A-D for PID Control
- ❖ 15-bit output D-A
- ❖ Fuzzy + PID microprocessor-based control
- ❖ Fast input sampling rate 200msec for PID Control
- ❖ Two level of function complexity
- ❖ 50 Profiles, 1000 Segments in Total
- ❖ Differential control
- ❖ Auto-tuning and Self Tuning function
- ❖ Sleep mode function
- ❖ " Soft-start " Ramp and Dwell timer
- ❖ Universal inputs(Thermocouple, RTD, mA, VDC)
- ❖ Analog input for remote set point and CT
- ❖ Event input for changing function & set point
- ❖ Programmable digital filter
- ❖ Hardware lockout + remote lockout protection
- ❖ Loop break alarm
- ❖ Heater break alarm
- ❖ Sensor break alarm + Bumpless transfer
- ❖ Pump control

- ❖ 100msec Sampling rate and log speed for Data Acquisition
- ❖ Real time and Historical Trends for PV and SV

1.3 Process Control Card

The Process Control Card uses Fuzzy Logic plus PID microprocessor technology for its control. The Fuzzy Logic plus PID microprocessor based technology enables a process to reach a predetermined set point in the shortest time, with the minimum of overshoot during power-up or external load disturbance. The module can be easily plugging into the rear side IO slots of the paperless recorder. Various control and input parameters can be configured easily by using the touch screen menus and navigations.

This Process Control Card can be configured by using the Configuration Menu on the device or by using the PC Based Configuration Software.

Even though PID control has been used and proved to be an efficient controlling method by many industries for more than a decade, yet the PID is difficult to deal with some sophisticated systems such as second and higher order systems, long time-lag systems, during set point change and/or load disturbance circumstance etc. The PID principle is based on a mathematic modeling which is obtained by tuning the process. Unfortunately many systems are too complex to describe in numerical terms precisely. In addition to these, systems may be variable from time to time. In order to overcome the imperfection of PID control, the Fuzzy Technology is introduced.

What is the Fuzzy Control? It works like a good driver. Under different speeds and circumstances, he can control a car well with experiences he had before and does not require the knowledge of kinetic theory of motion. The Fuzzy Logic is a linguistic control which is different from the numerical PID control. It controls the system by experiences and does not need to simulate the system precisely as been controlled by PID.

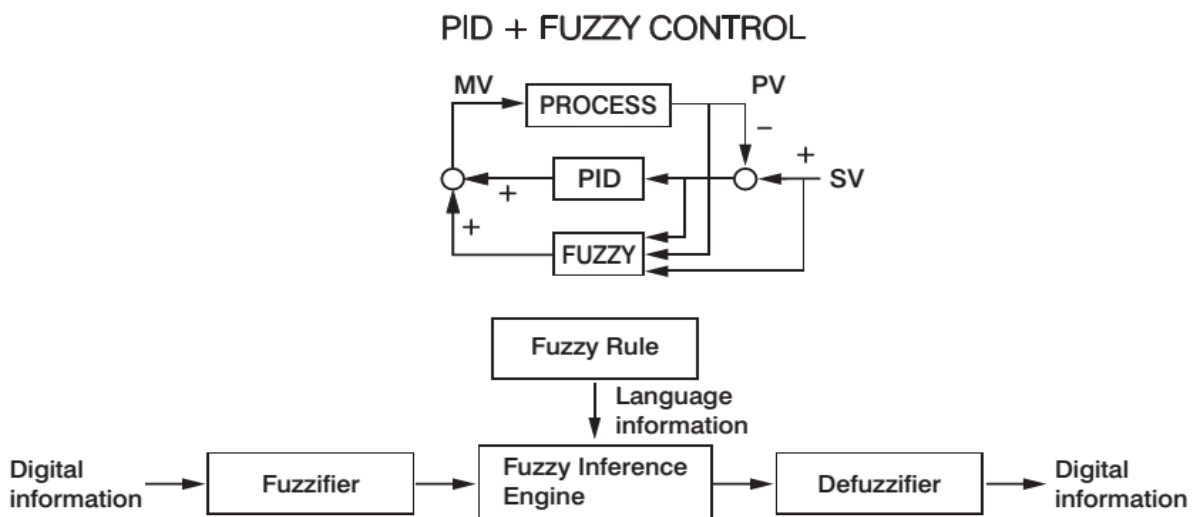

Figure 1-1.Fuzzy PID System Block Diagram

The function of Fuzzy Logic is to adjust PID parameters internally in order to make manipulation output value MV more flexible and adaptive to various processes. PID + Fuzzy Control has been proven to be an efficient method to improve the control stability as shown by the comparison of curves shown below.

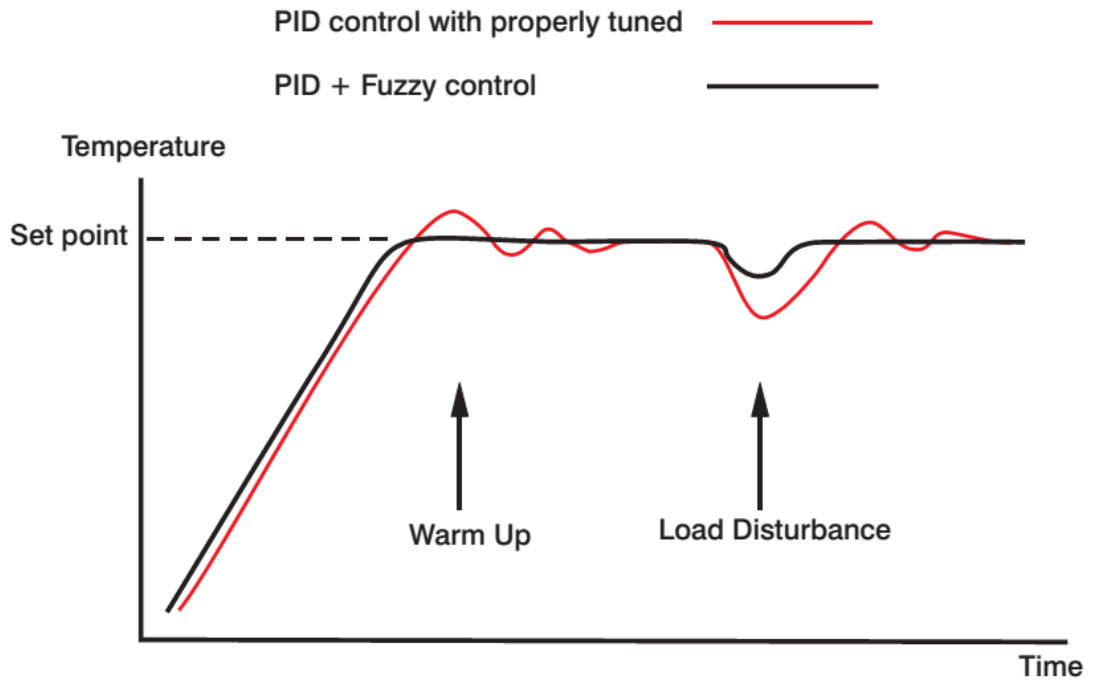

Figure 1-2. PID System Stability with and without Fuzzy

The Fuzzy Rule works like the below.

- ❖ If temperature difference is large and temperature rate is large, then MV is large.
- ❖ If temperature difference is high and temperature rate is small, then MV is small.

By using proprietary Fuzzy modified PID technology the control loop will minimize the overshoot and undershoot in a shortest time.

This Process Control Card can be configured as a single set point controller (static mode) or a ramp and dwell profiling controller (profile mode). The profile mode feature allows the user to program up to 50 profiles with up to 32 free format Segments (ramp, dwell, jump or end) each. The total segments available for the product are 1000 segments.

The Process Control Card contains the following features.

1.3.1 Flexible Configuration of Program

There are up to 32 segments can be defined for a profile. Each segment can be configured as a ramp or a dwell (soak) segment or defining a repeat number of cycles at arbitrary location within the profile and finally terminated by an end segment. The user can edit a currently running profile.

1.3.2 Maximum Capacity of Program

There are at most 50 Profiles can be defined and 1000 segments totally available for all profiles. Each Profile can contain maximum of 32 Segments and limited to 1000 Segments in Total.

1.3.3 Event Input

The Event input feature allows the user to select one of eight functions below.

- ❖ Enter Profile Run Mode
- ❖ Enter Profile Hold Mode
- ❖ Abort Profile Mode
- ❖ Enter Manual Mode
- ❖ Perform Failure Transfer
- ❖ Enter Off Mode
- ❖ Advance to the next segment
- ❖ Select second set of PID values

1.3.4 Programmable Event Outputs

Up to 3 Relays are configurable for event outputs and the state of each output can be defined for each segment and end of profile.

1.3.5 High Accuracy

This Process Control Card is manufactured with custom designed ASIC(Application Specific Integrated Circuit) technology which contains a 18-bit A to D converter for high resolution measurement (true 0.1 F resolution for thermocouple and PT100) and a 15-bit D to A converter for linear current or voltage control output. The ASIC technology provides improved operating performance with low cost and enhanced reliability and higher density.

1.3.6 Fast Sampling Rate

The sampling rate of the input A to D converter reaches 5 times/second (200msec). The fast sampling rate allows this Process Control Card to control fast processes.

1.3.7 Fuzzy Control

The function of Fuzzy control is to adjust PID parameters from time to time in order to make manipulation output value more flexible and adaptive to various processes. The results are to enable a process to reach a predetermined set point in the shortest time with the minimum of overshoot and undershoot during power-up or external load disturbance.

1.3.8 Auto-tuning

The auto-tuning function allows the user to simplify initial setup for a new system. A clever algorithm is provided to obtain an optimal set of control parameters for the process, and it can be applied either as the process is warming up (cold start) or as the process has been in steady state (warm start).

1.3.9 Lockout Protection

According to actual security requirement, a password is provided to prevent the unit from being changed abnormally.

1.3.10 Bumpless Transfer

Bumpless transfer allows the controller to continue to control by using its previous value as the sensor breaks. Hence, the process can be well controlled temporarily as like the sensor is normal.

1.3.11 Digital Filter

A first order low pass filter with a programmable time constant is used to improve the stability of process value. This is particularly useful in certain application where the process value is too unstable to read.

1.3.12 Soft-start Ramp

The ramping function is performed during power up as well as any time the set point is changed. It can be ramping up or ramping down. The process value will reach the set point with a predetermined constant rate.

1.3.13 Pump Control

In addition the fast sampling rate, this Process Control Card has superior noise rejection capability. So it can be used for pressure control of a Pump which is driven by Variable Frequency Drives.

1.4 Expansion I/O Modules for PID

The Paperless Recorder have the option to use PID function on it by using the Process Control Card in to it on the one of the 4 rear slots .

1.4.1 PID Control Module

This module is useful for single loop PID Control. This consists of Two Signal Inputs, one Event Input and control output and Alarm output as per the specification.

1.5 Smart Mechanism

The data is recorded in manufacturer special binary format. It is not possible to manipulate the data. This feature guarantees the security and reliability of the recorded data .

1.6 Process Control Card PC201 Ordering Code

PC201- □ □ □ □

A B C D

A: Output 1

- 0: None
- 1: Relay 2A/240VAC
- 2: Pulse voltage to drive SSR, 5V/30mA
- 3: Isolated 4-20mA/0-20mA (OM95-3)
- 4: Isolated 1-5V/0-5V (OM95-4)
- 5: Isolated 0-10V (OM95-5)
- 6: Triac output 1A/240VAC,SSR
- C: Pulse voltage to drive SSR, 14V/40mA (OM94-7)

B: Output 2

- 0: None
- 1: Relay 2A/240VAC
- 2: Pulse voltage to drive SSR, 5V/30mA
- 3: Isolated 4-20mA/0-20mA (OM95-3)
- 4: Isolated 1-5V/0-5V (OM95-4)
- 5: Isolated 0-10V (OM95-5)
- 6: Triac output 1A/240VAC,SSR
- 7: Isolated 20VDC/25mA power supply (DC94-1)
- 8: Isolated 12VDC/40mA power supply (DC94-2)
- 9: Isolated 5VDC/80mA power supply (DC94-3)
- C: Pulse voltage to drive SSR, 14V/40mA (OM94-7)

C: Alarm 1

- 0: None
- 1: Form C relay 2A/240VAC

D: Alarm 2

- 0: None
- 1: Form A relay 2A/240VAC

1.7 Specification

1.7.1 Input1

Resolution: 18 bits

Sampling Rate: 5 times / second

Maximum Rating: -2 VDC minimum, 12 VDC maximum (1 minute for mA input)

Temperature Effect: 1.5uV/°C for all inputs except mA input, ±3.0uV/°C for mA input

Sensor Lead Resistance Effect:

T/C: 0.2uV/ohm;

3-wire RTD: 2.6°C/ohm of resistance difference of two leads;

2-wire RTD: 2.6° C/ohm of resistance sum of two leads

Burn-out Current: 200nA

Common Mode Rejection Ratio (CMRR): 120dB

Normal Mode Rejection Ratio (NMRR): 55dB

Sensor Break Detection:

Sensor Open for TC, RTD and mV inputs

Sensor short for RTD input

Below 1 mA for 4-20 mA input,

Below 0.25V for 1 - 5 V input,

Unavailable for other inputs.

Sensor Break Responding Time:

Within 4 seconds for TC, RTD and mV inputs,

0.1 second for 4-20 mA and 1 - 5 V inputs.

Characteristics:

Type	Range	Accuracy @ 25°C	Input Impedance
J	-120°C to 1000°C (-184°F to 1832°F)	±2°C	2.2 MΩ
K	-200C to 1370 C (-328°F to 2498°F)	±2°C	2.2 MΩ
T	-250°C to 400°C (-418°F to 752°F)	±2°C	2.2 MΩ
E	-100°C to 900°C(-148°F to 1652°F)	±2°C	2.2 MΩ
B	0°C to 1800°C(32°F to 3272°F)	±2°C(200°C to 1800° C)	2.2 MΩ

Type	Range	Accuracy @ 25°C	Input Impedance
R	0°C to 1767.8°C(32°F to 3214°F)	±2°C	2.2 MΩ
S	0°C to 1767.8°C(32°F to 3214°F)	±2°C	2.2 MΩ
N	-250°C to 1300°C(-418°F to 2372°F)	±2°C	2.2 MΩ
L	-200°C to 900°C(-328°F to 1652°F)	±2°C	2.2 MΩ
PT100(DIN)	-210°C to 700°C (-346°F to 1292°F)	±0.4°C	1.3KΩ
PT100(JIS)	-200°C to 600°C(-328°F to 1112°F)	±0.4°C	1.3Ω
mV	-8mV to 70mV	±0.05%	2.2 MΩ
mA	-3mA to 27mA	±0.05%	70.5Ω
V	-1.3V to 11.5V	±0.05%	302KΩ

Table 1-1. Input 1 Characteristics

1.7.2 Input2

Resolution: 18 bits

Sampling Rate: 5 times / second

Maximum Rating: -2 VDC minimum, 12 VDC maximum (1 minute for mA input)

Temperature Effect: 1.5uV/°C for all inputs except mA input, ±3.0uV/°C for mA input

Common Mode Rejection Ratio (CMRR): 120dB

Normal Mode Rejection Ratio (NMRR): 55dB

Sensor Break Detection:

Below 1 mA for 4-20 mA input,

Below 0.25V for 1 - 5 V input,

Unavailable for other inputs.

Sensor Break Responding Time: 0.5 Seconds

Characteristics:

Type	Range	Accuracy @ 25°C	Input Impedance
CT94-1	0.0 to 50.0 A	±2% of Reading ±0.2A	302KΩ

Type	Range	Accuracy @ 25°C	Input Impedance
mA	-3mA to 27mA	±0.05%	70.5Ω+(0.8V/Input Current)
V	-1.3V to 11.5V	±0.05%	302KΩ

Table 1-2. Input 2 Characteristics

1.7.3 Input3 (Event Input)

Logic Low: -10V minimum, 0.8V maximum.

Logic high: 2V minimum, 10V maximum

External pull-down Resistance: 400 KΩ maximum

External pull-up Resistance: 1.5 MΩ minimum

Functions: Select second set point and/or PID, Reset alarm 1 and/or alarm 2, Disable output 1 and/or output 2, Remote lockout.

1.7.4 Output1/Output2

Relay Rating: 2A/240 VAC, life cycles 200,000 for Resistive load

Pulsed Voltage: Source Voltage 5V, current limiting resistance 66Ω

Linear Output Characteristics:

Type	Zero Tolerance	Span Tolerance	Load Capacity
4 to 20mA	3.8-4 mA	20-21 mA	500 Ω max
0 to 20mA	0 mA	20-21 mA	500 Ω max
0 to 5V	0 V	5 -5.25 V	10KΩ min
1 to 5V	0.95 to 1V	5 -5.25 V	10KΩ min
0 to 10V	0 V	10 - 10.5 V	10KΩ min

Table 1-3. Output Characteristics

Linear Output

Resolution: 15 bits

Output Regulation: 0.01 % for full load change

Output Settling Time: 0.1 sec. (stable to 99.9 %)

Isolation Breakdown Voltage: 1000 VAC

Temperature Effect: ± 0.0025 % of SPAN / $^{\circ}\text{C}$

Triac (SSR) Output

Rating: 1A / 240 VAC

Inrush Current: 20A for 1 cycle

Min. Load Current: 50 mA RMS

Max. Off-state Leakage: 3 mA RMS

Max. On-state Voltage: 1.5 V RMS

Insulation Resistance: 1000 M Ω minimum at 500 VDC

Dielectric Strength: 2500 VAC for 1 minute

Type	Tolerance	Maximum Output Current	Ripple Voltage	Isolation Barrier
20V	± 0.5 V	25 mA	0.2 Vp-p	500 VAC
12V	± 0.3 V	40 mA	0.1 Vp-p	500 VAC
5V	± 0.15 V	80 mA	0.05 Vp-p	500 VAC

Table 1-4. SSR Output Characteristics

1.7.5 Alarm 1/ Alarm 2

Alarm 1 Relay: Form A or Form B, Max. Rating 2A/240VAC, life cycles 100,000 for resistive load.

Alarm 2 Relay: Form A, Max. Rating 2A/240VAC, life cycles 200,000 for resistive load.

Alarm Mode: Normal, Latching, Hold, Latching / Hold.

Dwell Timer: 0 - 6553.5 minutes

Alarm Functions: Dwell timer, Deviation High / Low Alarm, Deviation Band High / Low Alarm, PV1 High / Low Alarm, PV2 High / Low Alarm, PV1 or PV2 High / Low Alarm, PV1-PV2 High / Low Alarm, Loop Break Alarm, Sensor Break Alarm.

1.7.6 Control Mode

Output 1: Reverse (heating) or direct (cooling) action

Output 2: PID cooling control, cooling P band 1~255% of PB

ON-OFF: 0.1 - 100.0(F) hysteresis control (P band = 0)

P or PD: 0 - 100.0 % offset adjustment

PID: Fuzzy logic modified Proportional band 0.1 ~ 900.0°F, Integral time: 0 - 1000 Seconds, Derivative time 0 - 360.0 seconds

Cycle Time: 0.1 - 100.0 seconds

Manual Control: Heat (MV1) and Cool (MV2)

Auto-tuning: (MV2) Cold start and warm start

Self-tuning: Select None and YES

Failure Mode: Auto-transfer to manual mode while sensor break or A-D converter damage

Sleep Mode: Enable or Disable

Ramping Control: 0 - 900.0°F/minute or 0 - 900.0°F/hour ramp rate

Power Limit: 0 - 100 % output 1 and output 2

Pump / Pressure Control: Sophisticated functions provided

Remote Set Point: Programmable range for voltage or current input

Differential Control: Control PV1-PV2 at set point

1.7.7 Digital Filter

Function: First Order

Time Constant: 0, 0.2, 0.5, 1, 2, 5, 10, 20, 30, 60 seconds programmable

2 Installation and Wiring

 Some times Dangerous voltages capable of causing death are present in this instrument. Before doing installation or any troubleshooting procedures the power to the equipment must be switched off and isolated. Units suspected of being faulty must be disconnected and removed to a properly equipped workshop for testing and repair. Component replacement and internal adjustments must be made by a qualified maintenance person only.

 To minimize the possibility of fire or shock hazards, do not expose this instrument to rain or excessive moisture

 Do not use this instrument in areas under hazardous conditions such as excessive shock, vibration, dirt, moisture, corrosive gases or oil. The ambient temperature of the areas should not exceed the maximum rating specified in the specification

2.1 Unpacking

Upon receipt of the shipment remove the unit from the carton and inspect the unit for shipping damage. If any damage found then contact local representative immediately. Note the model number, serial number for future reference when corresponding with our service center. The serial number (S/N) is labeled on the box and the housing of Paperless Recorder

 Remove stains from this equipment using a soft, dry cloth. Do not use harsh chemicals, volatile solvents such as thinner or strong detergents to clean the equipment in order to avoid deformation.

The Paperless Recorder is designed for indoor use and not in any hazardous area. It should be kept away from shock, vibration, and electromagnetic fields such as variable frequency drives, motors and transformers. It is intended to operate under the following environmental conditions.

Environmental Parameter	Specification
Operating Temperature	0°C to 50 °C
Humidity	20% to 90% RH(Non-condensing)
Altitude	2000 M Maximum

Table 2-1.Environmental Specification

2.2 Input Output Wiring Connection

2.2.1 Wiring Precautions



Sometimes Dangerous voltages capable of causing death are present in this instrument. Before doing installation or any troubleshooting procedures the power to the equipment must be switched off and isolated. Units suspected of being faulty must be disconnected and removed to a properly equipped workshop for testing and repair. Component replacement and internal adjustments must be made by a qualified maintenance person only.

- ❖ Utmost Care must be taken to ensure that the maximum voltage rating specified on the label is not exceeded.
- ❖ It is recommended to use an external fuse or an external switch rated at 2A/250 VAC for panel mount type wiring.
- ❖ The tightening torque on the Screw terminals should not exceed 0.4 N-m (3.6 Lb-in or 4.0 Kg F-cm).
- ❖ Except Thermocouple Wiring, all other wires used to be Standard Copper Conductor With maximum Gauge of 18AWG
- ❖ Grounding must be connected prior to turning on the Equipment with minimum of 1.6mm diameter conductor for protective grounding.

2.2.2 PID Control Module

This is a single loop PID Control Module which consists of Universal Input.

The Modules needs to be inserted to the rear slots or removed from the rear slots at the Power OFF condition. Failure to do so may cause damage to the module or device or both. The Device will automatically detect the Module at Power ON, once it is inserted in to the rear slots.

The Module output can be configured by using the configuration Menu. The configuration Menu can be reached by pressing Menu and then pressing More and then pressing Config key. It will display a tree type configuration layout for easy user configuration. By using Up/Down Key and Enter Key, PID Controller and Profile configuration window can be reached. In this window the user can configure the Controller parameters and profiles of PID Control Module. The user can select the desired output type and other parameters for analog output in this window.

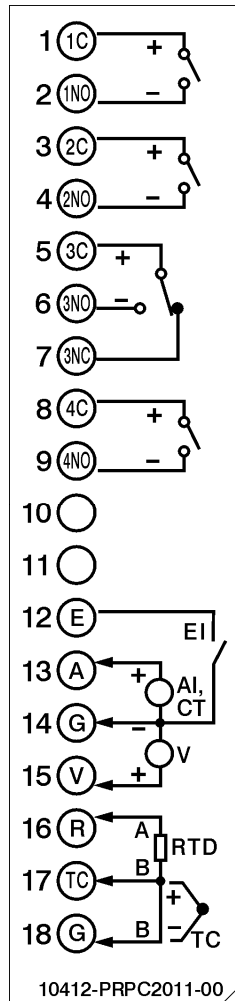

Figure 2-1. Process Control Card Wiring Diagram

Note:

- ❖ The IO Modules should not be removed or Inserted to the device when the Power is ON. This should be carried out in the Power OFF Condition only.
- ❖ For removing the IO Modules, First remove the metal screws then remove the plastic screws, after that press the lock on the top and bottom of the Card and pull to remove it. Failing to do so will damage the IO Card. Please follow the Recorder user manual for more information.
- ❖ The Maximum Torque for the metal screw is 3Kg-cm (2.6in-lb) and the Maximum Torque for the plastic screw is 0.8Kgf-cm (.7in-lb).
- ❖ Calibration should be carried out by a qualified Engineer with qualified equipments only.
- ❖ Thermocouple inputs requires 1 hour initial warm up time during initial setup.

3 Process Control Card Features

This Chapter will explain the features of the Process Control Card.

3.1 Configuration

The Process Control Card can be configured by using the tree type configuration layout of the Paperless Recorder easily. This is much useful for the user to configure all necessary configurations without missing any configuration.

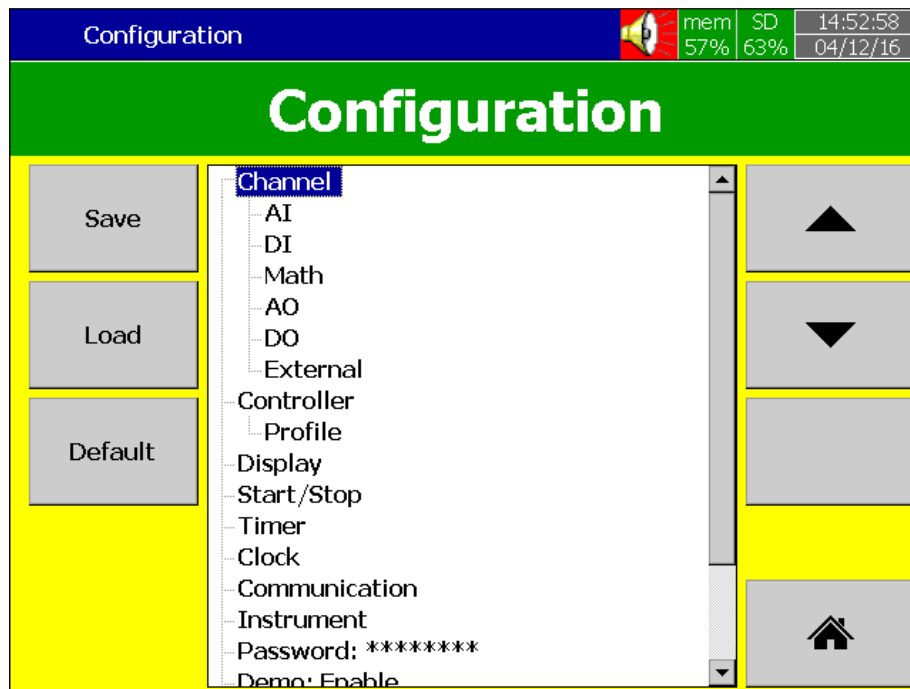

Figure 3-1. Configuration Layout

3.2 Controller

The PID Module includes PID Controller function in the Paperless recorder and log the data. The PID Control module is used to control the process.

3.3 Ramp & Dwell Function

The PID Control Module includes Ramp & Dwell function. It is useful to control the process with varying set point time to time. There are 50 different Profiles can be configured with 32 Segments/Profile with the limit of 1000 Segments totally.

3.4 On Field Calibration

The Device allows the user to do on field calibration for the device. No need to send the device to factory for Calibration

4 Process Control Card Functions

This Section will explain the functions of Process Control Card. The user can configure the device as per their requirement by using the user friendly configuration menu.

The below is the home screen of paperless recorder. This screen will be displayed when the device powered on.

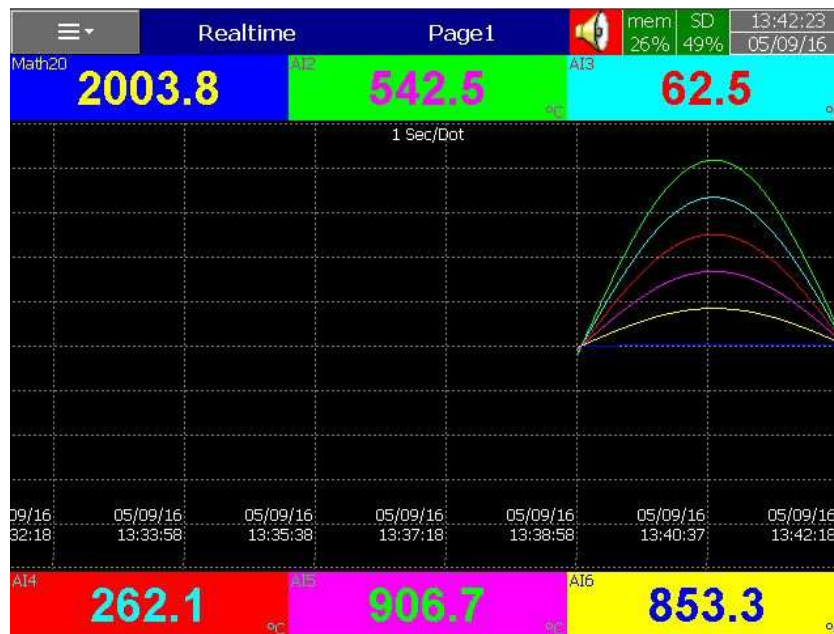



Figure 4-1.Home Screen

4.1 Menus

Press  Soft key to access the menu in the furnace controller. The below menu screen will show the available menus.

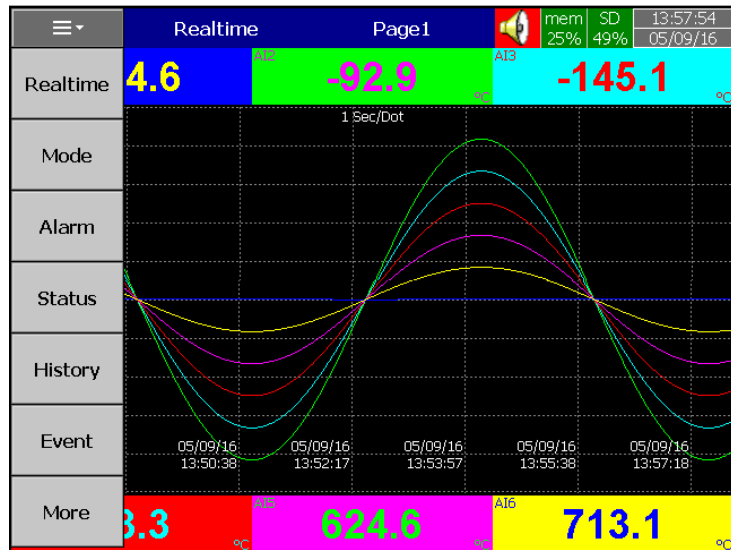

Figure 4-2.Menu Screen

Press **Real time** to access the real time trend display pages of the furnace controller. Press the **Page no** to view the respective display pages. Press **Overview** to view the digital display of all channels. Press **C1** to view the PID Controller Module display.

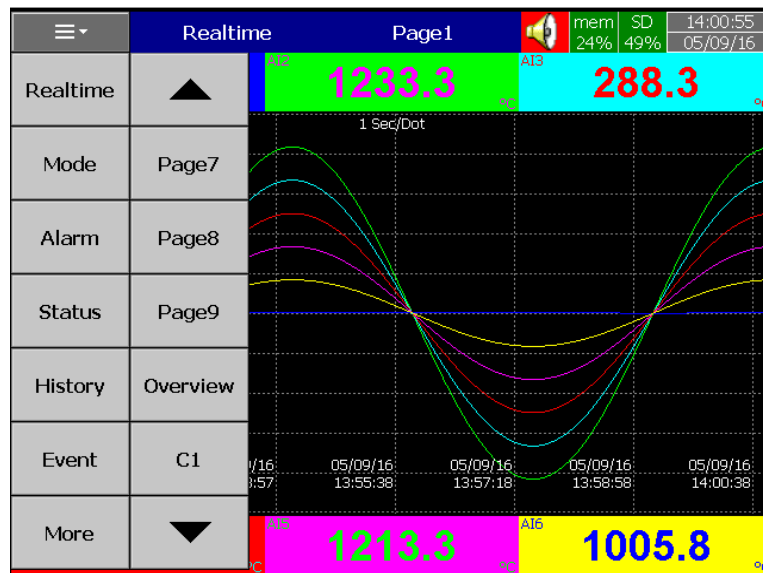

Figure 4-3.Real Time Menu

Realtime		Overview		mem	SD	14:04:03
↑	AI1 -184.8 °C	AI2 -117.3 °C	AI3 -153.1 °C	24%	49%	05/09/16
↑	AI5 613.8 °C	AI6 707.7 °C	AI7 1003.5 °F			
↓	AI9 204.5 °F	AI10 575.4 °F	AI11 1745.3 °F			
↓	AI13 -60.0 °C	AI14 16.67 %	AI15 33.33 %			
	AI17 83.33 %	AI18 66.67 %	AI19 590.4 °F			
	AI21 62.5 °F	AI22 405.4 °F	AI23 1552.6 °F			
	AI24 1512.6 °F	Math1 1188.2	Math2 1309.1			
	Math3 357.6	Math4 571.7	Math5 1131.6			
	Math6 900.8	Math7 66.7	Math8 83.3			

Figure 4-4. Overview Display

Batch1-1		C1		mem	SD	11:36:12
				92%	91%	10/13/16
Out1 <input checked="" type="checkbox"/>	PV	-23.9 °C		Run		
Out2 <input type="checkbox"/>	SV	55.0		Hold		
Alm1 <input type="checkbox"/>	▲ <input checked="" type="checkbox"/>	Segment: 00:00:00		Stop		
Alm2 <input type="checkbox"/>	▼ <input type="checkbox"/>	1		Set		
Run <input checked="" type="checkbox"/>	Profile:	1				
Hold <input type="checkbox"/>						

Figure 4-5. PID Controller Module Display

Press **Mode** to access the menu for different display modes. The user can select the desired display mode to display as per their requirements like **trend**, **Bar**, **Digit** or **Mix** mode.

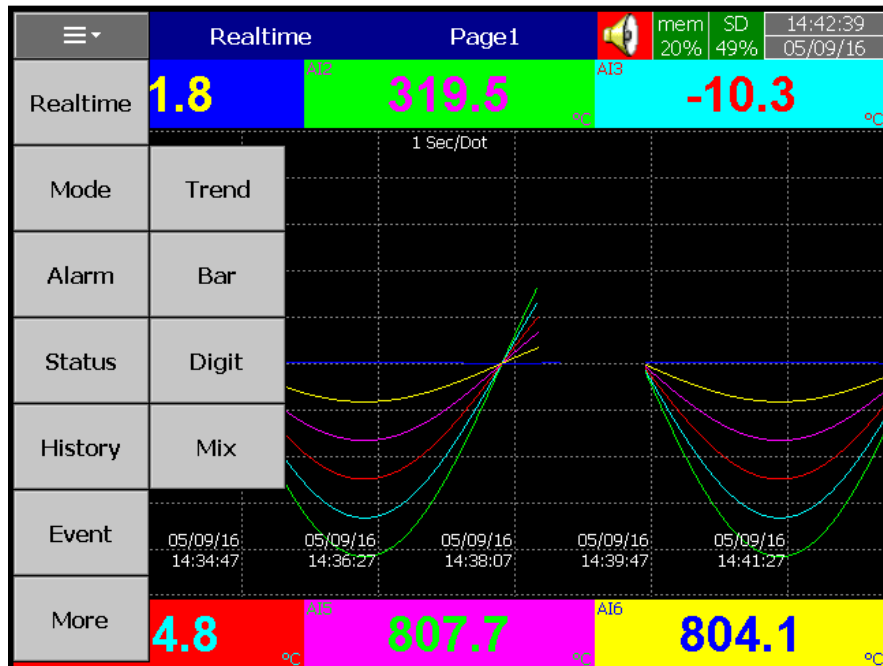

Figure 4-6. Display Modes

Press **Alarm** to view Real time Alarms and acknowledge using Ack key.



Figure 4-7. Real Time Alarms

Press **History** to access the historical data of the individual pages and do the remarking. The user can write their own comments by using Handwriting function . This is explained in detail in the respective Chapter.

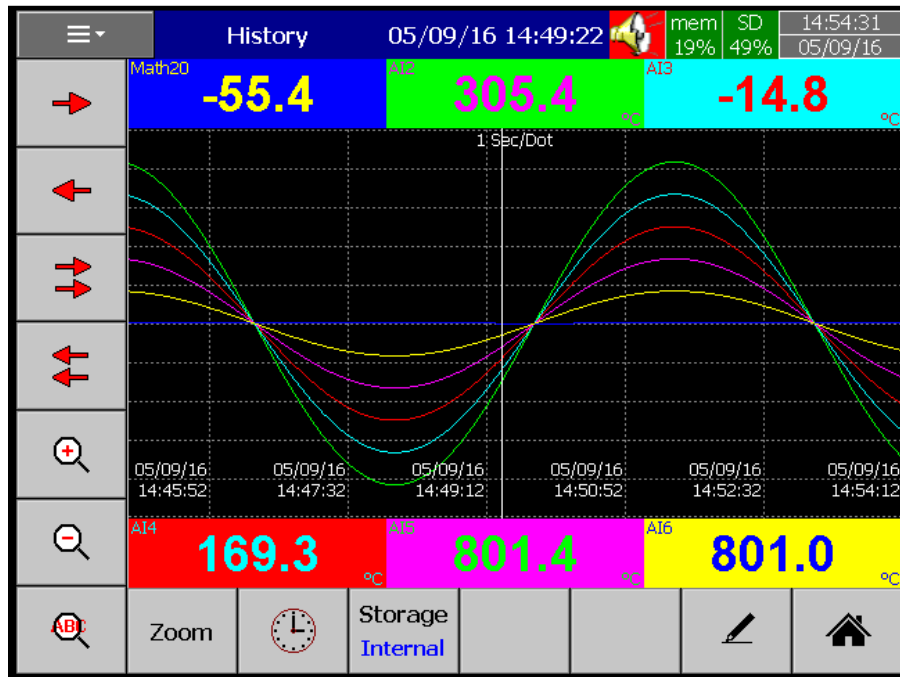

Figure 4-8. Historical Data Screen

Press **Event** to access the Historical Event and Reports from Internal and External memory. Press **Storage** to toggle between internal memory and External Memory like SD Card or USB Disk.

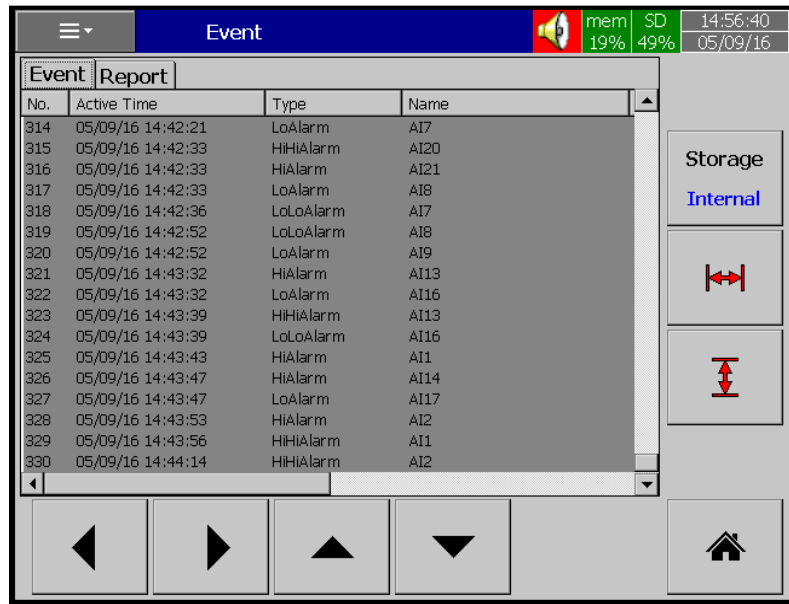







Figure 4-9.Event History

Press  Key to Scroll Page Horizontally and  Key to Scroll Page Vertically.

Press   Keys to page Up and Down. Press   Key to switch between Reports and Events.

In **Report** display press Mode to display the reports in Daily, Weekly, Monthly and List Modes.

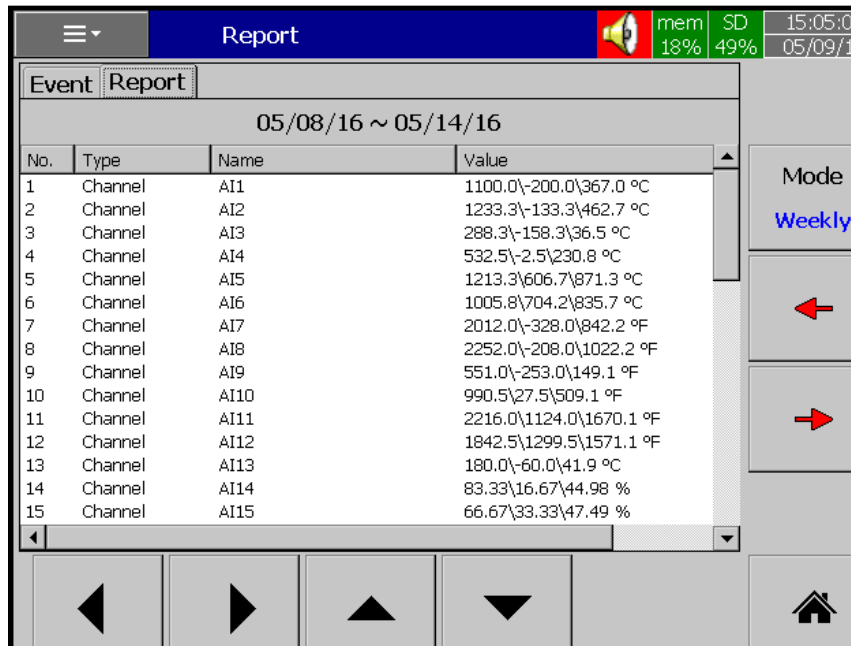

Figure 4-10. Report Screen

Press **More** to access more menus like dump, Clear, Operate, Config, Start/Pause, Shut down Menus.

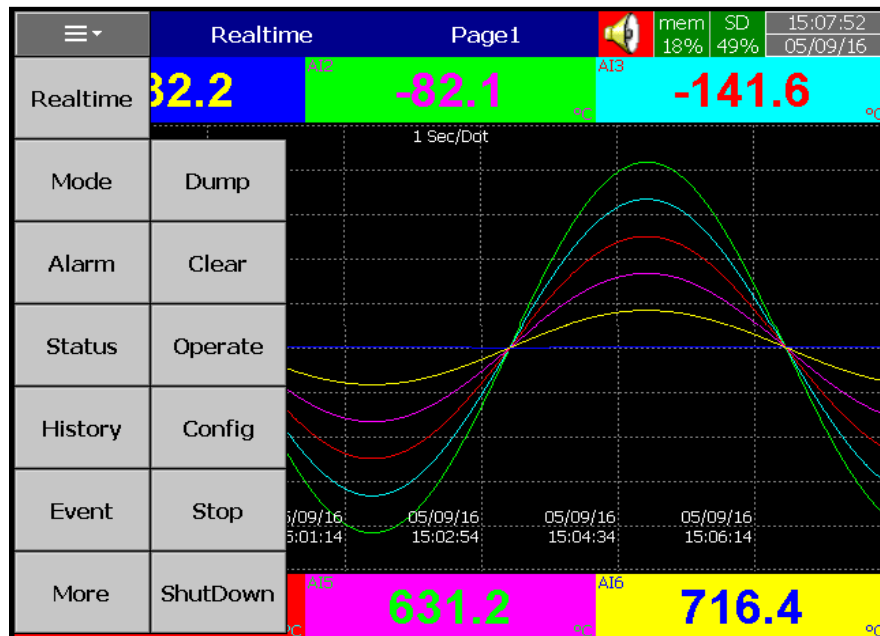

Figure 4-11. More Menu

Press **Dump** to Dump the data from Internal memory to External memory like SD Card or USB Disk.

Press **Clear** to Clear all the data in Internal memory.

Press **Operate** to Operate the desired job from the list.

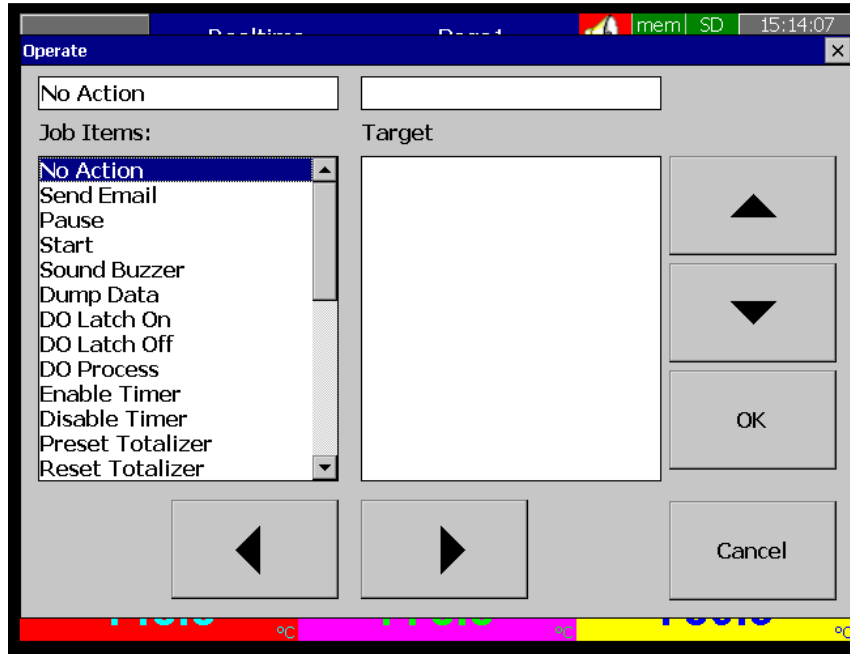

Figure 4-12. Operate Menu

Press **Config** to access Tree type Configuration Lay out and perform configuration as per the desired application.

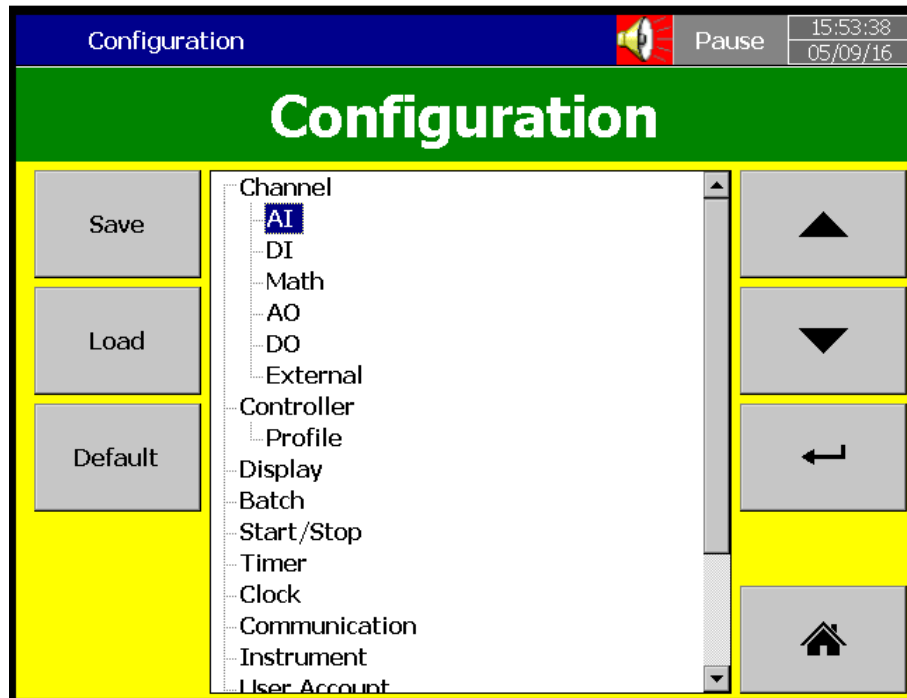



Figure 4-13. Configuration Layout

Press **Save** to save the configuration to SD Card or USB Device. Press **Load** to load the configuration from SD Card or USB Disk.

Press **Default** to load the default configuration from Internal memory.

Press  key to go to home page.

Press   Keys to move Up and Down to select the desired menu.

Press  Key to Enter to the Selected Menu.

Press **Start/Stop** to Start and Stop logging. The status will be shown in the Status bar on the top of the screen.

Press **Shut down** to Stop and Shut down the Furnace controller.

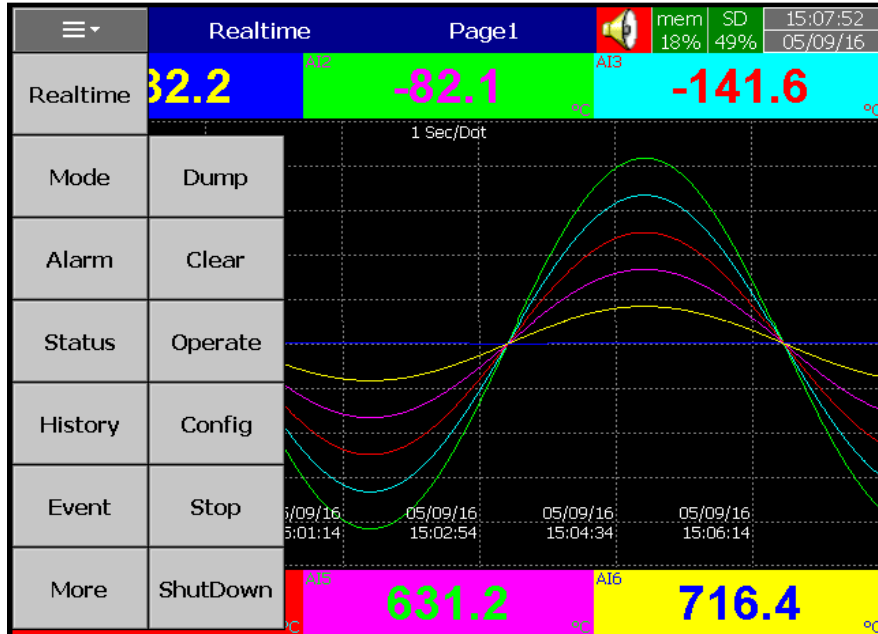

Figure 4-14. More Menu

4.2 Status Bar

The Status bar will be shown on top of every page. This will show the status of the memory, Alarm, logging status with real time Date and Time of the System.



Figure 4-15. Status Bar During Logging



Figure 4-16. Status Bar During Logging Stopped



Figure 4-17. Status Bar during Logging with Batch function



Figure 4-18. Status Bar During Logging Stopped with Batch Function

4.3 Process Control Card Configuration

This Section will explain the configuration for Process Control Card functions. Press



(Menu) and then press More then press Config to Enter to Configuration Screen. A Tree type configuration will be displayed for the easy configuration. In addition to that Save Load, Default and Home Soft keys also available.

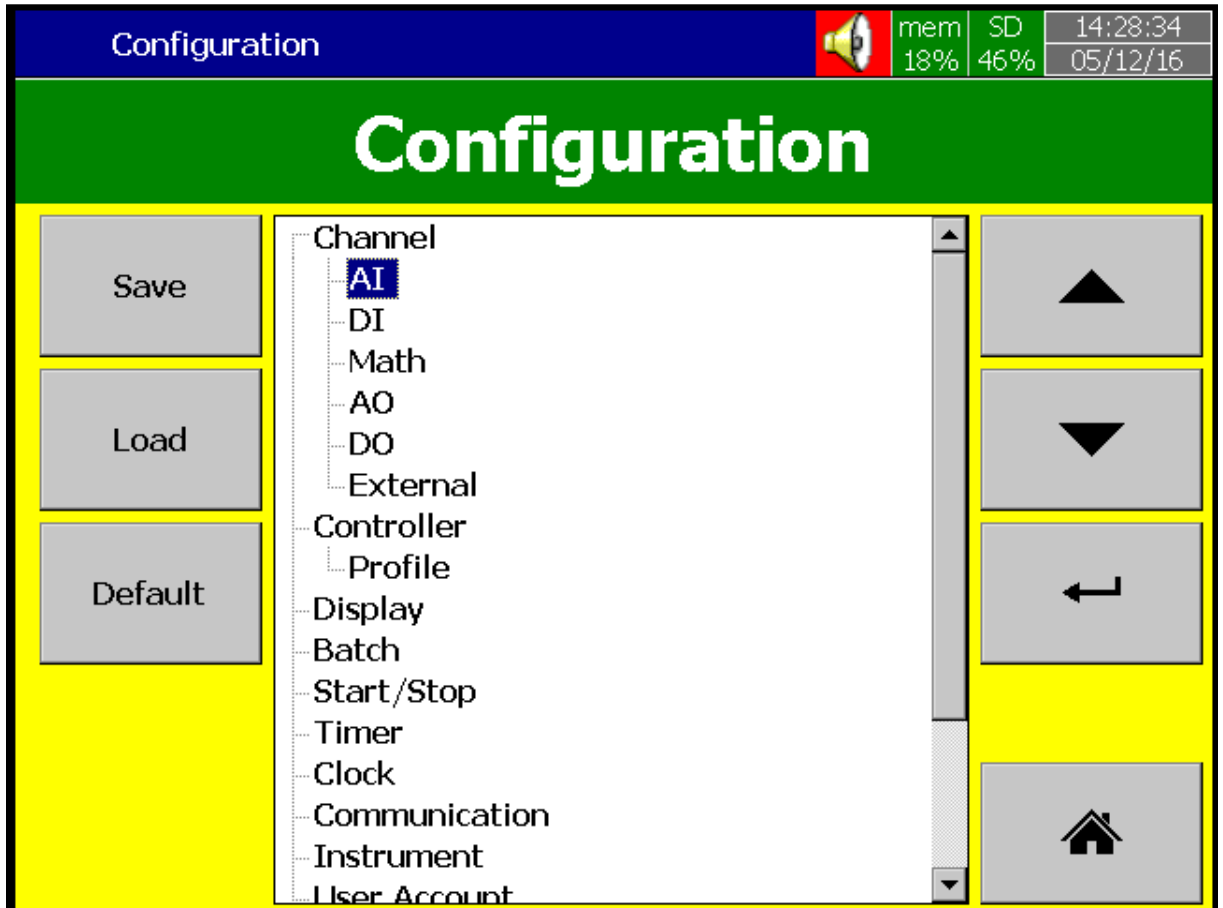
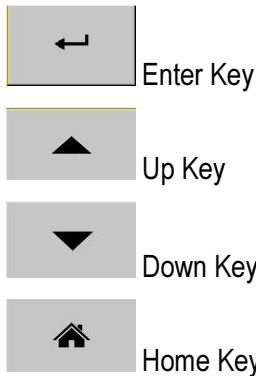

Figure 4-19.Tree Type Configuration Layout

Soft Keys

The below Soft Keys are available for the user to configure.



Various options are available to select the configuration Parameters.

- ❖ The user can move the cursor up and down using the soft key and press the Enter Soft key to Enter in to the highlighted parameter configuration
- ❖ The user can touch the desired parameter in the configuration tree and press Enter Soft key to Enter in to that parameter Configuration
- ❖ The user can double touch the desired parameter in the configuration tree to Enter in to that parameter configuration

Press **Save** to save the configuration to SD Card or USB Device. Press **Load** to load the configuration from SD Card or USB Disk. Press **Default** to load the default configuration from Internal memory.

Press  key to return to home page.

The following section will explain the detailed explanation of configuration of the device.

4.3.1 Process Control Card Configuration

This section will explain the configuration of Process Control Process Control Card Channels. The Process Control Card configuration will have two sections for configuration as below

- ❖ Controller
- ❖ Profile

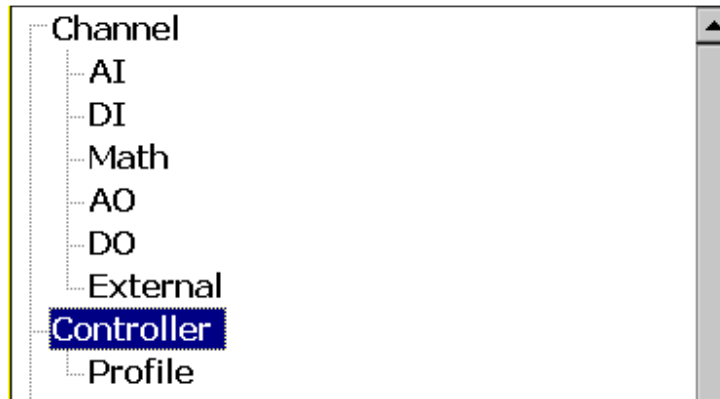





Figure 4-20.Process Control Card Channel Configuration

4.3.1.1 Controller

Press **Controller** and press **Enter Key** to Entering in to the Process Control Card controller configuration. Initially it displays **C1** as the first controller configuration. Use the navigational keys to select the next Controller Channels .Use the   key move to

other Controller Channels. Use   key to move between the different controller Configuration Parameters.

After completing the configuration press **Back** button and then press  to return to main display and save the configuration automatically.

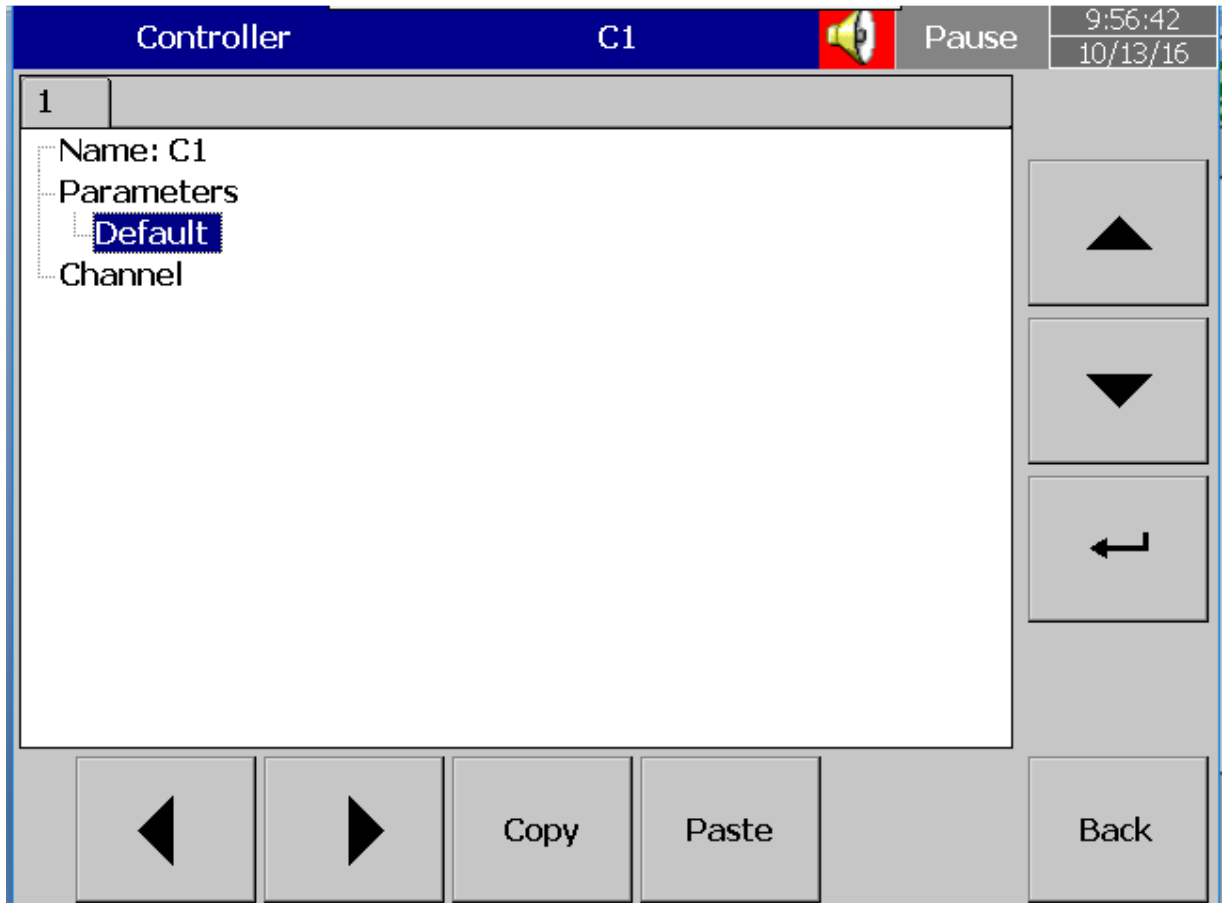

Figure 4-21.Process Control Card Channel Configuration

4.3.1.1.1 Name

Enable the user to define the name for each channel with the maximum limit of 18 Characters.

Select "Name", then Press "**Enter**", soft key, a keyboard with several keys appears. Press "**Shift**" to select special characters. Press "**Caps**" to select capital letters. Press soft key "**OK**" after entering a new channel name.

4.3.1.1.2 Parameter

This will allow the user to configure the PID Control function on the Process Control Card. Press **Parameter** and then press **Enter** Soft key to access the parameter configuration table. In the Configuration table the user can edit the parameters of the Process Control Card as per their requirement by selecting the desired parameter using the UP DOWN key and then press the Enter Soft Key. The Enter Soft key will be disabled for the restricted parameters.

Default allows the user to load the default configuration of the Process Control Card Parameters

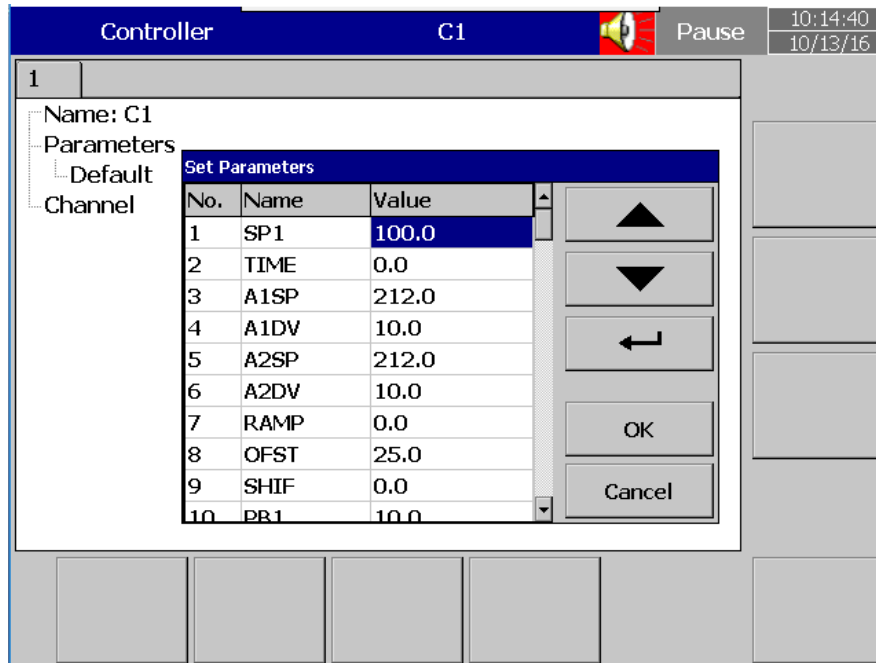

Figure 4-22.Process Control Card Configuration Window

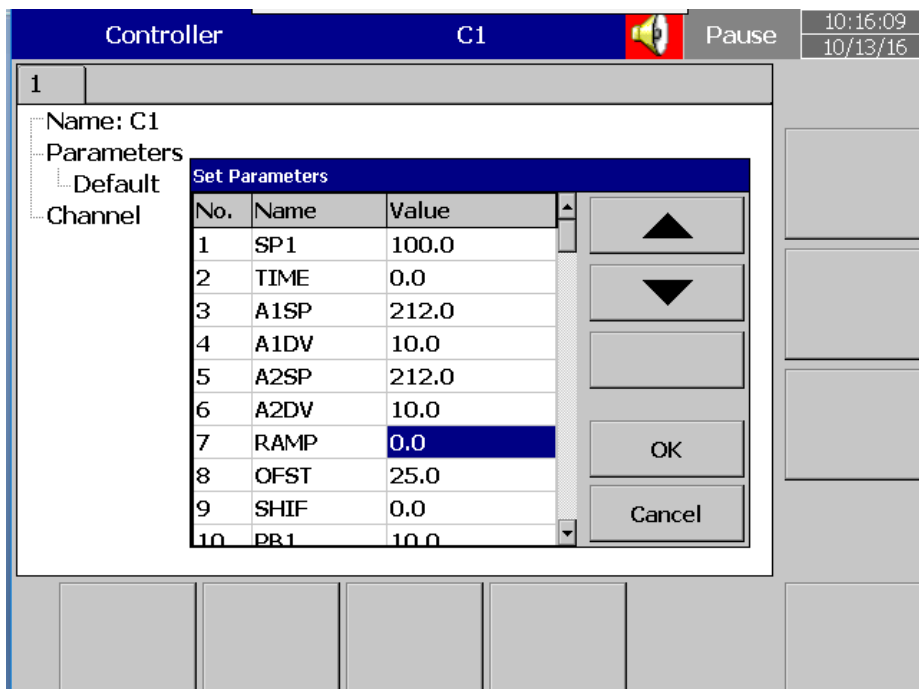

Figure 4-23.Process Control Card Configuration Window for Read only Parameter

The below table shows the list of parameters available in the Process Control Card for PID Control function.

Parameter Notation	Parameter Description	Range Low ^{*B}	Range High ^{*B}	Default Value ^{*C}	Unit ^{*E}
SP1	Set point 1	SP1L	SP1H	100.0° C (212.0°F)	PV
TIME	Dwell Time	0	6553.5	0.0	minute
A1SP	Alarm 1 Set point	*B1	*B1	100.0° C (212.0° F)	*E1
A1DV	Alarm 1 Deviation Value	-200.0°C (-360.0°F)	200.0°C (360.0°F)	10.0°C (18.0°F)	*E1
A2SP	Alarm 2 Set point	*B1	*B1	100.0°C (212.0°F)	*E2
A2DV	Alarm 2 Deviation Value	-200.0°C (-360.0°F)	200.0°C (360.0°F)	10.0°C (18.0°F)	*E2
RAMP	Ramp Rate	0	500.0°C (900.0°F)	0.0	*E3
OFST	Offset Value for P control	0	100.0	25.0	%
REFC	Reference Constant for Specific Function	0	60	2	
SHIF	PV1 Shift (offset) Value	-200.0°C (-360.0°F)	200.0°C (360.0°F)	0.0	PV1
PB1	Proportional Band 1 Value	0	500.0°C (900.0°F)	10.0°C (18.0°F)	PV
TI1	Integral Time 1 Value	0	1000	100	Sec

Parameter Notation	Parameter Description	Range Low ^{*B}	Range High ^{*B}	Default Value ^{*C}	Unit ^{*E}
TD1	Derivative Time 1 Value	0	360.0	25.0	Sec
CPB	Cooling Proportional Band Value	1	255	100	% of PB
DB	Heating-Cooling Dead Band	-36.0	36.0	0	% of PB
SP2	Set point 2	*B2	*B2	37.8°C (100.0°F)	PV
PB2	Proportional Band 2 Value	0	500.0°C (900.0°F)	10.0°C (18.0°F)	PV
TI2	Integral Time 2 Value	0	1000	100	Sec
TD2	Derivative Time 2 Value	0	360.0	25.0	Sec
O1HY	Output 1 ON-OFF Control Hysteresis	0.1	55.6°C (100.0°F)	0.1	PV
A1HY	Hysteresis Control of Alarm 1	0.1	10.0°C (18.0°F)	0.1	*E1
A2HY	Hysteresis Control of Alarm 2	0.1	10.0°C (18.0°F)	0.1	*E2
PL1	Output 1 Power Limit	0	100	100	%
PL2	Output 2 Power Limit	0	100	100	%
FUNC	Function Complexity Level	0 ^{*B3}	1 ^{*B3}	1	
COMM	Communication Interface Type	0 ^{*B4}	8 ^{*B4}	1	

Parameter Notation	Parameter Description	Range Low ^{*B}	Range High ^{*B}	Default Value ^{*C}	Unit ^{*E}
PROT	COMM Protocol Selection	0 ^{*B5}	0 ^{*B5}	0	
ADDR	Address Assignment of Digital COMM	1	255		
BAUD	Baud Rate of Digital COMM	0 ^{*B7}	9 ^{*B7}	5	
DATA	Data Bit count of Digital COMM	0 ^{*B8}	1 ^{*B8}	1	
PARI	Parity Bit of Digital COMM	0 ^{*B9}	2 ^{*B9}	0	
STOP	Stop Bit Count of Digital COMM	0 ^{*B10}	1 ^{*B9}	0	
AOFN	Analog Output Function	0 ^{*B11}	7 ^{*B11}	0	
IN1	IN1 Sensor Type Selection	0 ^{*B12}	17 ^{*B12}	1 (0)	
IN1U	IN1 Unit Selection	0 ^{*B13}	2 ^{*B13}	0 (1)	
DP1	IN1 Decimal Point Selection	0 ^{*B14}	3 ^{*B14}	1	
IN1L	IN1 Low Scale Value	-19999	45536	0	^{*E5}
IN1H	IN1 High Scale Value	-19999	45536	1000	^{*E5}
SP1L	SP1 Low Scale Value	-19999	45536	0.0°C (32.0°F)	PV
SP1H	SP1 High Scale Value	-19999	45536	1000.0°C (1832.0°F)	PV

Parameter Notation	Parameter Description	Range Low ^{*B}	Range High ^{*B}	Default Value ^{*C}	Unit ^{*E}
IN2	IN2 Signal Type Selection	0 ^{*B13}	20 ^{*B15}	1	
IN2U	IN2 Unit Selection	0 ^{*B13}	2 ^{*B13}	2	
DP2	IN2 Decimal Point Selection	0 ^{*B14}	3 ^{*B14}	1	
IN2L	IN2 Low Scale Value	-19999	45536	0	^{*E6}
IN2H	IN2 High Scale Value	-19999	45536	1000	^{*E6}
EIFN	Event Input Function	0 ^{*B16}	9 ^{*B16}	1	
OUT1	Output 1 Function	0 ^{*B17}	1 ^{*B17}	0	
O1TY	Output 1 Signal Type	0 ^{*B18}	8 ^{*B18}	0	
CYC1	Output 1 Cycle Time	0.1	100.0	18.0	Sec
O1FT	Output 1 Failure Transfer Mode	0 ^{*B18}	0 ^{*B18}	-0.1	%
OUT2	Output 2 Function	0 ^{*B18}	0 ^{*B18}	0	
O2TY	Output 2 Signal Type	0 ^{*B18}	0 ^{*B18}	0	
CYC2	Output 2 Cycle Time	0.1	100.0	18.0	Sec
O2FT	Output 2 Failure Transfer Mode	-0.1 ^{*B19}	100.0 ^{*B19}	-0.1	%
A1FN	Alarm 1 Function	0 ^{*B22}	15 ^{*B22}	2	
A1MD	Alarm 1 Operation Mode	0 ^{*B23}	3 ^{*B23}	0	
A1FT	Alarm 1 Failure Transfer Mode	0 ^{*B24}	1 ^{*B24}	1	
A2FN	Alarm 2 Function	0 ^{*B22}	15 ^{*B22}	2	

Parameter Notation	Parameter Description	Range Low ^{*B}	Range High ^{*B}	Default Value ^{*C}	Unit ^{*E}
A2MD	Alarm 2 Operation Mode	0 ^{*B23}	3 ^{*B23}	0	
A2FT	Alarm 2 Failure Transfer Mode	0 ^{*B24}	1 ^{*B24}	1	
SELF	Self Tune Function Selection	0 ^{*B25}	1 ^{*B25}	0	
SLEP	Sleep mode Function Selection	0 ^{*B26}	1 ^{*B26}	0	
PVMD	PV Mode Selection	0 ^{*B27}	3 ^{*B27}	0	
SP2F	Format of Set point 2 Value	0 ^{*B28}	1 ^{*B28}	0	
FILT	Filter Damping Time Constant of PV	0 ^{*B29}	9 ^{*B29}	2	
SPMD	Set point Mode Selection	0 ^{*B30}	5 ^{*B30}	0	
SEL1	Select 1'st Parameter	0 ^{*B31}	18 ^{*B31}	0	
SEL2	Select 2'nd Parameter	0 ^{*B31}	18 ^{*B31}	0	
SEL3	Select 3'rd Parameter	0 ^{*B31}	18 ^{*B31}	0	
SEL4	Select 4'th Parameter	0 ^{*B31}	18 ^{*B31}	0	
SEL5	Select 5'th Parameter	0 ^{*B31}	18 ^{*B31}	0	
DRIF	Warm-up Drift Calibration Factor	-5.0°C	5.0°C		°C
AD0	A to D Zero Calibration Coefficient	-360	360		
ADG	A to D Gain Calibration Coefficient	-199.9	199.9		

Parameter Notation	Parameter Description	Range Low ^{*B}	Range High ^{*B}	Default Value ^{*C}	Unit ^{*E}
V1G	Voltage Input1 Gain Calibration Coefficient	-199.9	199.9		
CJTL	Cold Junction Low Temperature Calibration Coefficient	-5.0°C	40.0°C		°C
CJG	Cold Junction Gain Calibration Coefficient	-199.9	199.9		
REF1	Reference Voltage1 Calibration Coefficient for RTD1	-199.9	199.9		
SR1	Serial Resistance 1 Calibration Coefficient for RTD1	-199.9	199.9		
MA1G	mA input 1 Gain Calibration Coefficient	-199.9	199.9		
REF2	Reference Voltage2 Calibration Coefficient for RTD2	-199.9	199.9		
SR2	Serial Resistance 2 Calibration Coefficient for RTD2	-199.9	199.9		
V2G	Voltage input 2 Gain Calibration Coefficient	-199.9	199.9		
MA2G	mA input 2 Gain Calibration Coefficient	-199.9	199.9		
O2L	Output 2 Low Calibration Coefficient	0	360.0		
O2H	Output 2 High Calibration Coefficient	0	900.0		
SIG1	Point 1 Signal Value of Special Sensor	-19999	45536		

Parameter Notation	Parameter Description	Range Low ^{*B}	Range High ^{*B}	Default Value ^{*C}	Unit ^{*E}
IND1	Point 1 Indication Value of Special Sensor	-19999	45536		PV
SIG2	Point 2 Signal Value of Special Sensor	-19999	45536		
IND2	Point 2 Indication Value of Special Sensor	-19999	45536		PV
SIG3	Point 3 Signal Value of Special Sensor	-19999	45536		
IND3	Point 3 Indication Value of Special Sensor	-19999	45536		PV
SIG4	Point 4 Signal Value of Special Sensor	-19999	45536		
IND4	Point 4 Indication Value of Special Sensor	-19999	45536		PV
SIG5	Point 5 Signal Value of Special Sensor	-19999	45536		
IND5	Point 5 Indication Value of Special Sensor	-19999	45536		PV
SIG6	Point 6 Signal Value of Special Sensor	-19999	45536		
IND6	Point 6 Indication Value of Special Sensor	-19999	45536		PV
SIG7	Point 7 Signal Value of Special Sensor	-19999	45536		
IND7	Point 7 Indication Value of Special Sensor	-19999	45536		PV
SIG8	Point 8 Signal Value of Special Sensor	-19999	45536		
IND8	Point 8 Indication Value of Special Sensor	-19999	45536		PV

Parameter Notation	Parameter Description	Range Low ^{*B}	Range High ^{*B}	Default Value ^{*C}	Unit ^{*E}
SIG9	Point 9 Signal Value of Special Sensor	-19999	45536		
IND9	Point 9 Indication Value of Special Sensor	-19999	45536		PV
TYPE	Signal Type of Special Sensor	0	3		
DATE	Manufacturing Date of Product	0	3719		
NO	Serial Number of Product	1	999		
HOUR	Working Hour Value	0	65535		Hour
HRLO	Fractional Hour Value	0	0.9		0.1Hour
ERR1	Historical Error Record 1	0	FFFF	0	
ERR2	Historical Error Record 2	0	FFFF	0	
DELI	ASCII Input Delimiter	0000	007F	000A	
BPL1	OUT1 Bumpless Transfer Value	0	100.00		%
BPL2	OUT2 Bumpless Transfer Value	0	100.00		%
PVHI	Historical Maximum Value of PV	-19999	45536		PV
PVLO	Historical Minimum Value of PV	-19999	45536		PV
CJCL	Sense Voltage of Cold Junction Calibration Low	31.680	40.320		mV
FILE	Default File Selection	0 ^{*B32}	1 ^{*B32}		

Parameter Notation	Parameter Description	Range Low ^{*B}	Range High ^{*B}	Default Value ^{*C}	Unit ^{*E}
PV	Current Process Value	-19999	45536		PV
SV	Current set point Value	-19999	45536		PV
MV1	Current Output 1 Value	0	100.00		%
MV2	Current Output 2 Value	0	100.00		%
ALM	Contains Conditional Code of parameters Resolution and Current Alarm Status	0 ^{*B33}	EF7F ^{*B33}		
DV	Current Deviation (PV-SV)Value	-12600	12600		PV
PV1	IN1 Process Value	-19999	45536		^{*E5}
PV2	IN2 Process Value	-19999	45536		^{*E6}
PB	Current Proportional Band Value	0	500.0°C (900.0°F)		PV
TI	Current Integral Time Value	0	4000		Sec
TD	Current Derivative Time Value	0	1440		Sec
EROR	Current Error Code	0 ^{*B34}	40 ^{*B34}		
PROG	Program Identification Code Contains Program Number and Version Number	0 ^{*B35}	15.99 ^{*B35}		
MODE	Contains Lockout Status code and Current system mode	0 ^{*B36}	3.5 ^{*B34}		
CMND	Command Password	0	65535		
JOB	Job Password	0	65535		

Parameter Notation	Parameter Description	Range Low ^{*B}	Range High ^{*B}	Default Value ^{*C}	Unit ^{*E}
CJCT	Cold Junction Compensation Temperature	-40.0 ° C	90.0° C		°C
PVR	Current Process Rate Value	-16383	16383		PV/min
PVRH	Maximum Process Rate Value	-16383	16383		PV/min
PVRL	Minimum Process Rate Value	-16383	16383		PV/min
SPC	Current Target Value of set point	-19999	45536		PV

Table 4-1.PID Parameter List

^{*B}: The ranges of some parameters are dependent on the input types. The range of IN1 and IN2 for various input type is shown in the following table:

Input Type	Range Low	Rang High
J_T/C	-120°C(-184°F)	1000°C(1832°F)
K_T/C	-200°C(-328°F)	1370°C(2498°F)
T_T/C	-250°C(-418°F)	400°C(752°F)
E_T/C	-100°C(-148°F)	900°C(1652°F)
B_T/C	0°C(32°F)	1820°C(3308°F)
R_T/C	0°C(32°F)	1767.8°C(3214°F)
S_T/C	0°C(32°F)	1767.8°C(3214°F)
N_T/C	-250°C(-418°F)	1300°C(2372°F)
L_T/C	-200°C(-328°F)	900°C(1652°F)
PT100_DN	-210°C(-346°F)	700°C(1292°F)

Input Type	Range Low	Rang High
PT100_JS	-210°C(-346°F)	600°C(1112°F)
CT	0 Amps	90 Amps
Linear (mA or Voltage)	-19999	45536

Table 4-2.Process Control Card Input Range

*B1: Range For A1SP & A2SP

If A1FN=	Range of A1SP same as range of
PV1.H,PV1.L	IN1
PV2.H,PV2.L	IN2
P1.2 H,P1.2 L,D1.2 H ,D1.2 L	IN1,IN2

Table 4-3.Range of A1SP

If A2FN=	Range of A2SP same as range of
PV1.H,PV1.L	IN1
PV2.H,PV2.L	IN2
P1.2 H,P1.2 L,D1.2 H ,D1.2 L	IN1,IN2

Table 4-4.Range of A2SP

*B2: Range For SP2

If PVMD=	Range of SP2 same as range of
PV1	IN1
PV2	IN2
P1-2,P2-1	IN1,IN2

Table 4-5.Range Of SP2

*B3: Display Symbol and Description of FUNC

Parameter Value	Display Symbol	Description
0	BASC	Basic Function Mode
1	FULL	Full Function Mode

Table 4-6.Mode Selection

*B4: Display Symbol and Description For COMM

Parameter Value	Display Symbol	Description
0	NONE	No Communication Function
1	485	RS-485 Interface
2	232	RS-232 Interface
3	4-20	4-20mA Analog Retransmission Output
4	0-20	0-20mA Analog Retransmission Output
5	0-1V	0-1V Analog Retransmission Output
6	0-5V	0-5V Analog Retransmission Output
7	1-5V	1-5V Analog Retransmission Output
8	0-10V	0-10V Analog Retransmission Output

Table 4-7.Communication Mode

*B5: Display Symbol and Description For PROT

Parameter Value	Display Symbol	Description
0	RTU	Modbus RTU Mode
1	ASCI	Modbus ASCII Mode

Parameter Value	Display Symbol	Description
2	DNET	Devicenet Protocol
3	PBUS	Profibus Protocol
4	FBUS	Fieldbus Protocol
5	ABUS	Reserved
6	BNET	Reserved

Table 4-8.Communication Protocol

*B7: Display Symbol and Description For BAUD

Parameter Value	Display Symbol	Description
0	0.3	0.3 Kbits/Second Baud Rate
1	0.6	0.6 Kbits/Second Baud Rate
2	1.2	1.2 Kbits/Second Baud Rate
3	2.4	2.4 Kbits/Second Baud Rate
4	4.8	4.8 Kbits/Second Baud Rate
5	9.6	9.6 Kbits/Second Baud Rate
6	14.4	14.4 Kbits/Second Baud Rate
7	19.2	19.2 Kbits/Second Baud Rate
8	28.8	28.8 Kbits/Second Baud Rate
9	38.4	38.4 Kbits/Second Baud Rate

Table 4-9.Communication Baud Rate

*B8: Display Symbol and Description For DATA

Parameter Value	Display Symbol	Description
0	7BIT	7 Data Bits
1	8BIT	8 Data Bits

Table 4-10.Communication Data Length

*B9: Display Symbol and Description For PARI

Parameter Value	Display Symbol	Description
0	EVEN	Even Parity
1	ODD	Odd Parity
2	NONE	No Parity

Table 4-11.Communication Parity

*B10: Display Symbol and Description For STOP

Parameter Value	Display Symbol	Description
0	1 BIT	One Stop Bit
1	2 BIT	Two Stop Bits

Table 4-12.Communication Stop Bit

*B11: Display Symbol and Description For AOFN

Parameter Value	Display Symbol	Description
0	PV1	Retransmit IN1 Process Value
1	PV2	Retransmit IN2 Process Value
2	P1-2	Retransmit IN1-IN2 Difference Process Value
3	P2-1	Retransmit IN2-IN1 Difference Process Value
4	SV	Retransmit Set Point Value
5	MV1	Retransmit Output1 manipulation Value
6	MV2	Retransmit Output2 manipulation Value
7	DV	Retransmit Deviation(PV-SV) Value

Table 4-13 Function of AOFN

*B12: Display Symbol and Description For IN1

Parameter Value	Display Symbol	Description
0	J_TC	J Type Thermocouple
1	K_TC	K Type Thermocouple
2	T_TC	T Type Thermocouple
3	E_TC	T Type Thermocouple
4	B_TC	B Type Thermocouple
5	R_TC	R Type Thermocouple
6	S_TC	S Type Thermocouple
7	N_TC	N Type Thermocouple
8	L_TC	L Type Thermocouple
9	PT.DN	PT 100 Ohms DIN Curve

Parameter Value	Display Symbol	Description
10	PT.JS	PT100 Ohms JIS Curve
11	4-20	4-20mA Linear Current Input
12	0-20	0-20mA Linear Current Input
13	0-1V	0-1V Linear Voltage Input
14	0-5V	0-5V Linear Voltage Input
15	1-5V	1-5V Linear Voltage Input
16	0-10	0-10V Linear Voltage Input
17	SPEC	Special defined sensor Curve

Table 4-14 Selection of IN1 Type

*B13: Display Symbol and Description For IN1U & IN2U

Parameter Value	Display Symbol	Description
0	°C	Degree Celsius Unit
1	°F	Degree Fahrenheit Unit
2	PU	Process Unit

Table 4-15.Display Unit for IN1 & IN2

*B14: Display Symbol and Description For DP1 & DP2

Parameter Value	Display Symbol	Description
0	NO-DP	No Decimal Digit
1	1-DP	One Decimal Digit
2	2-DP	Two Decimal Digits
3	3-DP	Three Decimal Digits

Table 4-16.Decimal Digit for DP1&DP2

***B15:** Display Symbol and Description For IN2

Parameter Value	Display Symbol	Description
0	NONE	IN2 No Function
1	CT	Current Transformer Input
2	4-20	4-20mA Linear Current Input
3	0-20	0-20mA Linear Current Input
4	0-1V	0-1V Linear Voltage Input
5	0-5V	0-5V Linear Voltage Input
6	1-5V	1-5V Linear Voltage Input
7	0-10	0-10V Linear Voltage Input

Table 4-17.IN2 Input

***B16:** Display Symbol and Description For EIFN

Parameter Value	Display Symbol	Description
0	NONE	Event Input No Function
1	SP2	SP2 Activated to replace SP1
2	PID2	PB2, TI2, TD2 Activated to replace PB1, TI1, TD1
3	SP.P2	SP2, PB2, TI2, TD2 Activated to replace SP1, PB1, TI1, TD1
4	RS.A1	Reset Alarm 1 Output
5	RS.A2	Reset Alarm2 Output
6	R.A1.2	Reset Alarm1 & Alarm2 Output

Parameter Value	Display Symbol	Description
7	D.O1	Disable Output1
8	D.O2	Disable Output2
9	D.O1.2	Disable Output1 &Output 2
10	LOCK	Lock All Parameters

Table 4-18.EIFN Function

*B17: Display Symbol and Description For OUT1

Parameter Value	Display Symbol	Description
0	REVR	Reverse(Heating)Control Action
1	DIRT	Direct(Cooling)Control Action

Table 4-19.OUT1 Action

*B18: Display Symbol and Description For O1TY & O2TY

Parameter Value	Display Symbol	Description
0	RELY	Relay Output
1	SSRD	Solid State Relay Drive Output
2	SSR	Solid State Relay Output
3	4-20	4-20mA Current Module
4	0-20	0-20mA Current Module
5	0-1V	0-1V Voltage Module
6	0-5V	0-5V Voltage Module
7	1-5V	1-5V Voltage Module
8	0-10	0-10V Voltage Module

Table 4-20.OUT1 & OUT2 Type

*B19: Failure transfer mode for output 1 and output 2, select BPLS (bumpless transfer) or 0.0 ~ 100.0 % to continue output 1 and output 2 control function as the unit fails , power starts or manual mode starts.

*B20: Display Symbol and Description For OUT2

Parameter Value	Display Symbol	Description
0	NONE	Output 2 no function
1	COOL	PID cooling control
3	DCPS	DC power supply module installed

Table 4-21.OUT2 Function

*B21: Display Symbol and Description For DISF

Parameter Value	Display Symbol	Description
0	PV	Display PV Value
1	SV	Display SV Value

Table 4-22.Display Function

*B22: Display Symbol and Description For A1FN & A2FN

Parameter Value	Display Symbol	Description
0	NONE	No alarm function
1	TIMR	Dwell timer action
2	DE.HI	Deviation high alarm
3	DE.LO	Deviation low alarm

Parameter Value	Display Symbol	Description
4	DB.HI	Deviation band out of band alarm
5	DB.LO	Deviation band in band alarm
6	PV1.H	IN1 process value high alarm
7	PV1.L	IN1 process value low alarm
8	PV2.H	IN2 process value high alarm
9	PV2.L	IN2 process value low alarm
10	P1.2.H	IN1 or IN2 process value high alarm
11	P1.2.L	IN1 or IN2 process value low alarm
12	D1.2.H	IN1 IN2 difference process value high alarm
13	D1.2.L	IN1 IN2 difference process value low alarm
14	LB	Loop break alarm
15	SEN.B	Sensor break or A-D fails

Table 4-23. Alarm1 & Alarm 2 Function

*B23: Display Symbol and Description For A1MD & A2MD

Parameter Value	Display Symbol	Description
0	NORM	Normal alarm action
1	LTCH	Latching alarm action
2	HOLD	Hold alarm action
3	LT.HO	Latching & Hold action

Table 4-24. Alarm1 & Alarm2 Operation Mode

*B24: Display Symbol and Description For A1FT & A2 FT

Parameter Value	Display Symbol	Description
0	OFF	Alarm Output OFF as unit Fails
1	ON	Alarm Output ON as unit Fails

Table 4-25.Alarm1 & Alarm2 Failure Transfer Mode

*B25: Display Symbol and Description For SFLF

Parameter Value	Display Symbol	Description
0	NONE	Auto tuning (Self Tune) Function disabled
1	YES	Auto tuning (Self Tune) Function Enabled

Table 4-26.Auto Tuning

*B26: Display Symbol and Description For SLEP

Parameter Value	Display Symbol	Description
0	NONE	Sleep Mode Function disabled
1	YES	Sleep Mode Function Enabled

Table 4-27.Sleep Mode

*B27: Display Symbol and Description For PVMD

Parameter Value	Display Symbol	Description
0	PV1	Use PV1 as Process Value
1	PV2	Use PV2 as Process Value

Parameter Value	Display Symbol	Description
2	P1-2	Use PV1-PV2 Difference as Process Value
3	P2-1	Use PV2-PV1 Difference as Process Value

Table 4-28.PV Mode Selection

*B28: Display Symbol and Description For SP2F

Parameter Value	Display Symbol	Description
0	ACTU	Setpoint2 (SP2)is an Actual Value
1	DEVI	Setpoint2 (SP2) is an Deviation Value

Table 4-29.SP2 Set Point Format

*B29: Display Symbol and Description For FILT

Parameter Value	Display Symbol	Description
0	0	0 second time constant
1	0.2	0.2 second time constant
2	0.5	0.5 second time constant
3	1	1 second time constant
4	2	2 seconds time constant
5	5	5 seconds time constant
6	10	10 seconds time constant
7	20	20 seconds time constant
8	30	30 seconds time constant
9	60	60 seconds time constant

Table 4-30 Filter Damping Time Constant of PV

*B30: Display Symbol and Description For SPMD

Parameter Value	Display Symbol	Description
0	SP1.2	Use SP1 or SP2 (depends on EIFN) as set point
1	MIN.R	Use minute ramp rate as set point
2	HR.R	Use hour ramp rate as set point
3	PV1	Use IN1 process value as set point
4	PV2	Use IN2 process value as set point
5	PUMP	Selected for pump control

Table 4-31 Set Point Mode Selection

*B31: Display Symbol and Description For SEL1-SEL5

Parameter Value	Display Symbol	Description
0	NONE	No parameter put ahead
1	TIME	Parameter TIME put ahead
2	A1.SP	Parameter A1SP put ahead
3	A1.DV	Parameter A1DV put ahead
4	A2.SP	Parameter A2SP put ahead
5	A2.DV	Parameter A2DV put ahead
6	RAMP	Parameter RAMP put ahead
7	OFST	Parameter OFST put ahead
8	REFC	Parameter REFC put ahead
9	SHIF	Parameter SHIF put ahead
10	PB1	Parameter PB1 put ahead

Parameter Value	Display Symbol	Description
11	TI1	Parameter TI1 put ahead
12	TD1	Parameter TD1 put ahead
13	C.PB	Parameter CPB put ahead
14	DB	Parameter DB put ahead
15	SP2	Parameter SP2 put ahead
16	PB2	Parameter PB2 put ahead
17	TI2	Parameter TI2 put ahead
18	TD2	Parameter TD2 put ahead

Table 4-32 SEL Selection

*B32: Display Symbol and Description For FILE

Parameter Value	Display Symbol	Description
0	0	Perform Default Setting by using °C File
1	1	Perform Default Setting by using °F File

Table 4-33 Default File Selection

*B33: Description of Alarm Value

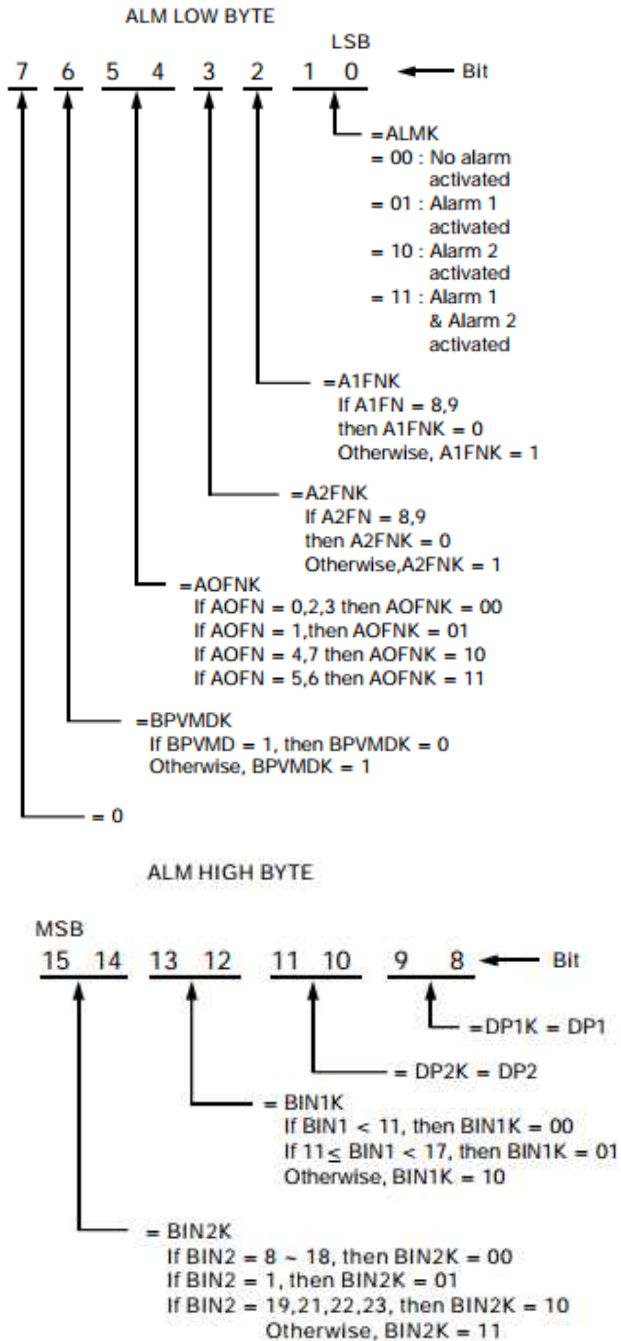

*B34: Error Messages

Error Code	Display Symbol	Error Description	Corrective Action
1	Er 01	Illegal setup values used: PV1 is used for both PVMD and SPMD that is meaningless for control.	Check and correct setup values of PVMD and SPMD, PV and SV can't use the same value for normal control
2	Er 02	Illegal setup values used: PV2 is used for both PVMD and SPMD that is meaningless for control	Same as error code1
3	Er 03	Illegal setup values used: P1-2 or P2-1 is used for PVMD while PV1 or PV2 is used for SPMD. Dependent values are used for PV and SV will produce incorrect result of control	Check and correct setup values of PVMD and SPMD. Difference of PV1 and PV2 can't be used for PV while PV1 or PV2 is used for SV
4	Er 04	Illegal setup values used: COOL is used for OUT2, but DIRT (cooling action) is already used for OUT1 or PID mode is not used for OUT1 (that is PB1 or PB2 =0, and T11 or T12 =0)	Check and correct setup values of OUT2, PB1, PB2, T11, T12 and OUT1. IF OUT2 is required for cooling control, the control should use PID mode (PB = 0, T1 = 0) and OUT1 should use reverse mode (heating action), otherwise, don't use OUT2 for cooling control

Error Code	Display Symbol	Error Description	Corrective Action
5	Er 05	Illegal setup values used: unequal IN1U and IN2U or unequal DP1 and DP2 while P1-2 or P2-1 is used for PVMD or, PV1 or PV2 is used for SPMD or, P1.2.H, P1.2.L, D1.2.H or D1.2.L is used for A1FN or A2FN.	Check and correct setup values of IN1U , IN2U, DP1, DP2, PVMD, SPMD, A1FN or A2FN. Same unit and decimal point should be used if both PV1 and PV2 are used for PV, SV, alarm1 or alarm 2.
6	Er 06	Illegal setup values used: OUT2 select =AL2 but A2FN select NONE	Check and correct setup values of OUT2 and A2FN. OUT2 will not perform alarm function if A2FN select NONE.
7	Er 07	Illegal setup values used: Dwell timer (TIMR) is selected for both A1FN and A2FN.	Check and correct setup values of A1FN and A2FN. Dwell timer can only be properly used for single alarm output.
9	Er 09	Communication error: receive error due to parity error, framing error, overrun error, receive buffer full error, frame check-sum error or receive disturbed	<ol style="list-style-type: none"> 1. Correct the communication software to meet the protocol requirements 2. Add a terminating resistor to the multi-drop link (RS-485) to minimize the noise. 3. Use twisted pair wire for RS-485 interface connection to minimize the noise. 4. Check the polarity of RS-485 interface connection.

Error Code	Display Symbol	Error Description	Corrective Action
10	Er 10	Communication error: bad function code	Correct the communication software to meet the protocol requirements.
11	Er 11	Communication error: register address out of range	Don't issue an over-range address of register to the slave.
12	Er 12	Communication error: access a non-existent parameter	Don't issue a non-existent parameter to the slave.
14	Er 14	Communication error: attempt to write a read only data	Don't write a read only data or a protected data to the slave.
15	Er 15	Communication error: write a value which is out of range to a register	Don't write an over-range data to the slave register.
17	Er 17	Computing error: Illegal (abnormal) floating point data	Software bug. Return to factory for repair.
18	Er 18	Computing error: Arithmetic result overflow or underflow	Software bug. Return to factory for repair.
19	Er 19	Computing error: divided by zero	Don't use an equal value for AOLO and AOHI.
20	Er 20	Computing error: Illegal BCD data entry	Software bug. Return to factory for repair.
21	Er 21	Timing error: A toD conversion data error due to overrun	A to D converter doesn't work properly. Return to factory for repair.

Error Code	Display Symbol	Error Description	Corrective Action
22	Er 22	Timing error: check-sum error received during multi-chip communication procedure	<ol style="list-style-type: none"> 1. Correct the multi-chip communication software to meet the protocol requirement. 2. Return to factory for repair.
23	Er 23	Timing error: wrong function code received during multi-chip communication procedure	<ol style="list-style-type: none"> 1. Correct the multi-chip communication software to meet the protocol requirement. 2. Return to factory for Repair.
26	AtEr	Fail to perform auto-tuning function	<ol style="list-style-type: none"> 1. The PID values obtained after auto-tuning procedure are out of range. Retry auto-tuning. 2. Don't change set point value during auto-tuning procedure. 3. Don't change Event input state during auto-tuning procedure. 4. Use manual tuning instead of auto-tuning.
27	CAER	Incorrect calibration procedure or tolerance of analog component too big to meet specified accuracy	<ol style="list-style-type: none"> 1. Pay more attention to the calibration procedures. 2. Return to factory for repair.

Error Code	Display Symbol	Error Description	Corrective Action
28	CAPE	Memory comparison error, different value detected in the EEPROM and mapped RAM	1.Check and correct the wiring and grounding problems to minimize the system noise. 2.Return to factory for repair.
29	EEPE	EEPROM can't be written correctly	Return to factory for repair.
32	CJER	Cold junction compensation device(s) malfunction	Return to factory for repair.
33	YYER	Key switch shorted or related PCB circuit shorted	Return to factory for repair.
34	LLL2	Input 2 (IN2) signal too low	1.Check if the input 2 sensor used is accordant with IN2 type selection. 2.Check the connection polarity of input 2 sensor. 3.Replace input 2 sensor.
35	HHH2	Input 2 (IN2) signal too high	1.Check if the input 2 sensor used is accordant with IN2 type selection. 2.Replace input 2 sensor.

Error Code	Display Symbol	Error Description	Corrective Action
36	LLL1	Input 1 (IN1) signal too low	1. Check if the input 1 sensor used is accordant with IN1 type selection. 2. Check the connection polarity of input 1 sensor. 3. Replace input 1 sensor.
37	HHH1	Input 1 (IN1) signal too high	1. Check if the input 1 sensor used is accordant with IN1 type selection. 2. Replace input 1 sensor.
38	SB2E	Input 2 (IN2) sensor break, or input 2 current below 1 mA if 4-20 mA is selected, or input2 voltage below 0.25V if 1 - 5V is selected	Replace input 2 sensor.
39	SB1E	Input 1 (IN1) sensor break, or input 1 current below 1 mA if 4-20 mA is selected, or input1 voltage below 0.25V if 1 - 5V is selected	Replace input 1 sensor.
40	ADER	A to D converter or related component(s) malfunction	Return to factory for repair.

Table 4-34. Error Codes and Corrective Actions

*B35:PROG CODE Description

Parameter Value	Specified product
0.XX	BTC-2500 controller
1.XX	BTC-4300 controller
2.XX	BTC-9500 controller
3.XX	BTC-8300 controller
4.XX	BTC-4300 controller & Process Control card of PR
5.XX	BTC-7200 controller
6.XX	BTC-9100 controller
7.XX	SM-40A smart panel meter
8.XX	Reserved
9.XX	ST-30A smart transmitter
10.XX	Reserved
11.XX	Reserved
12.XX	Reserved
13.XX	Reserved
14.XX	ST-20A smart transmitter (software setup)
15.XX	ST-20A smart transmitter (DIP switches setup)

Table 4-35 PROG CODE

***B36:** Display Symbol and Description of MODE

Parameter Value	Description
X.0	Perform normal mode
X.1	Enter calibration mode
X.2	Enter auto-tuning mode
X.3	Enter failure mode
X.4	Enter manual mode
X.5	Enter sleep mode
0.X	Unlock condition
1.X	SP1, SEL1 SEL5 are unlocked
2.X	Lock all parameters except SP1
3.X	All parameters are locked

Table 4-36 Mode

***C:** The Parameters are preset with the default values specified in the table during production

***E:** The unit PV means that the unit of parameter is the same as the unit of PV (process value).The unit of PV is determined by PVMD , IN1, IN2, IN1U, and IN2U.

***E1:** Unit determination for A1SP, A1DV and A1HY

If A1FN=	Range of A1SP same as range of
DE.HI,DE.LO,DB.HI,DB.LO	PV
PV1.H,PV1.L	PV1
PV2.H,PV.L	PV2
P1.2.H,P1.2.L,D1.2.H,D1.2.L	PV1,PV2

Table 4-37.Unit Determination for A1SP,A1DV,A1HY

*E2: Unit determination for A2SP, A2DV and A2HY

If A2FN=	Range of A2SP same as range of
DE.HI,DE.LO,DB.HI,DB.LO	PV
PV1.H,PV1.L	PV1
PV2.H,PV.L	PV2
P1.2.H,P1.2.L,D1.2.H,D1.2.L	PV1,PV2

Table 4-38. Unit Determination for A2SP, A2DV, A2HY

*E3: Unit determination for Ramp

If SPMD=	Unit
MIN.R	PV/Minute
HR.R	PV/Hour

Table 4-39. RAMP Unit

*E4: Unit determination for AOLO and AOHI

If AOFN=	Same Unit as Unit of
PV1	PV1
PV2	PV2
P1-2,P2-1	PV1,PV2
SV	PV
MV1,MV2	%

Table 4-40 . Unit Determination of AOLO & AOHI

*E5: Unit is the same as unit of PV1 (IN1)

*E6: Unit is the same as unit of PV2 (IN2)

4.3.1.1.3 Channel

The Channel will allow the user to configure the logging parameters. Press Channel and then press Enter Soft key to access the Channel parameter of Process Control Card.

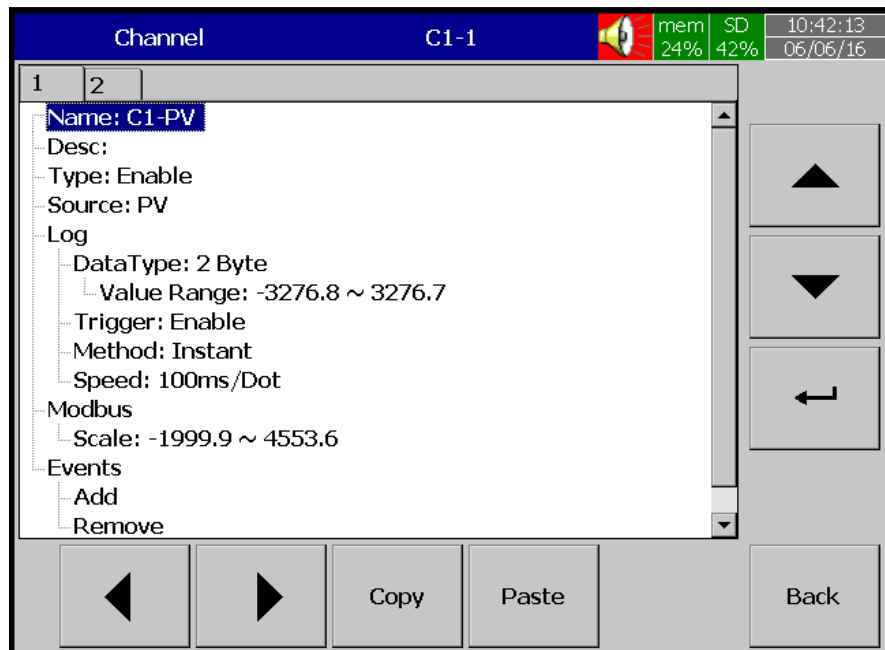

Figure 4-24.Process Control Card Channel Configuration

Name:

Enable the user to define the name for each channel with the maximum limit of 18 Characters. Select "Name", then Press "Enter", soft key, a keyboard with several keys appears. Press "Shift" to select special characters. Press "Caps" to select capital letters. Press soft key "OK" after entering a new channel name.

Desc:

The description about a specific channel on the display.

Type:

Option available to enable or disable the channel from logging.

Source:

There are two options available for source. They are as below

- ❖ PV
- ❖ SV

The first channel will show PV and the second Channel will show SV in source. These two parameters can be logged in the recorder from the Process Control Card.

- ❖ By using the  Key to switch between Channels.

Log:

This is to set the desired logging parameter settings

Data Type:

- 2 byte
- 2 byte range: -3276.8 to +3276.7

Trigger:

Two options are available

- ❖ **Disable:** Select disable while the recording of a specific channel is not required.
- ❖ **Enable:** Select Enable while the recording of a specific channel is required.

Method:

This is the method of logging measured data. Select Method and Press “**Enter**”, soft key to have the selection of different log methods. Then choose the required Log method. The available log methods are as below.

- ❖ **Instant:** logging the last measured data at the sampling interval
- ❖ **Average:** logging the averaged measured data at the sampling interval
- ❖ **Minimum:** logging the minimum measured data at the sampling interval
- ❖ **Maximum:** logging the maximum measured data at the sampling interval

Speed:

It is the logging speed (recording speed) of measured data. Select Log Speed and then choose log speed to one of the below.

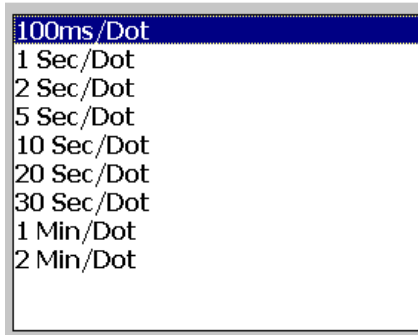

Figure 4-25.Log Speed

Modbus Scale:

Scale for reading the Analog Input Values through Modbus

Events

Events are generally used to generate Alarms. The Events can also be used to process Digital Output, Timer, Counter, Totalizers and to generate report.

There are maximum 5 Events can be added for Analog Inputs.

Press **Add** to Add the Events. Press **Remove** to Remove the Events.

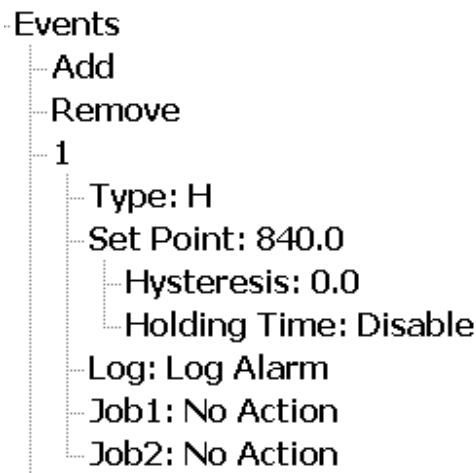

Figure 4-26.Events with Job

Type:

There are different types are available to select for Job of Event or Alarm. The available types are **H, L, HH, LL, Dev+, Dev-, and Error**

H: High limit. When the process is over high limit, the alarm or job is actuated.

L: Low limit. Any the process is lower than low limit, the alarm or job is actuated.

HH: High High limit, to set up another limit higher than high limit for double warning.

LL: Low Low limit, to set up another limit lower than low limit for double warning.

Dev+: Trigger an event on positive deviation of process value. The job or alarm is activated when process value is deviated more than the set point in positive direction. (Set point +Previous sampled Process Value)

Example:

Set point =10

At 10.00.01 Hrs Tag1=40

At 10.00.02 Hrs Tag1 = 51

Then, job or alarm is activated

Dev-: Trigger an event on negative deviation of process value. The job or alarm is activated when process value is deviated less than the set point in negative direction. (Previous sampled Process Value-Set point)

Example:

Set point =10

At 10.00.01 Hrs, Tag1=40

At 10.00.02 Hrs, Tag1 = 29

Then, job or alarm is activated.

Error: On Channel error, an alarm or job is activated

Set point: To set up the process value for actuating Job1 and /or Job2

Alarm

Log Alarm: Record alarms

Log Alarm (Auto Ack): Record alarms and acknowledge automatically

Log Event: Record events

Job1, Job2:

When an event occurs, the task to be performed is called the job. A typical example is to trigger **an alarm buzzer** in the event of a high temperature. Each Channel can accept five different types of events (or alarms) and each event can create two jobs. Please note that a job under Event is different from a job created by pressing the **Operate** key. The former is actuated by an event, and the latter is actuated by manual control, no event necessary.

Note: Please refer to the section "Jobs" in Recorder user manual for full details about various jobs available

Hysteresis

To avoid the event or alarm has been activated too often hysteresis value can be set for the alarm to change it in to normal state. Hysteresis value can be defined for the event trigger set point.

Holding time:

It refers to, suppose the set point is reached, but the user want to wait for some time to activate that action. This time is holding time. In process sometimes SP is reached but it will go down immediately, that might due to process instability. To encounter this issue the user have given an holding time, to see that PV stays at above that SP more than the holding time and then activate action for that event.

Example1

If the temperature is increased to more than 100 °C, log alarm and switch on digital output1. When the temperature is decreased to less than 50 °C, log the alarm and switch off the digital output1. Setting of events for the analog input in the channel configuration is as follows.

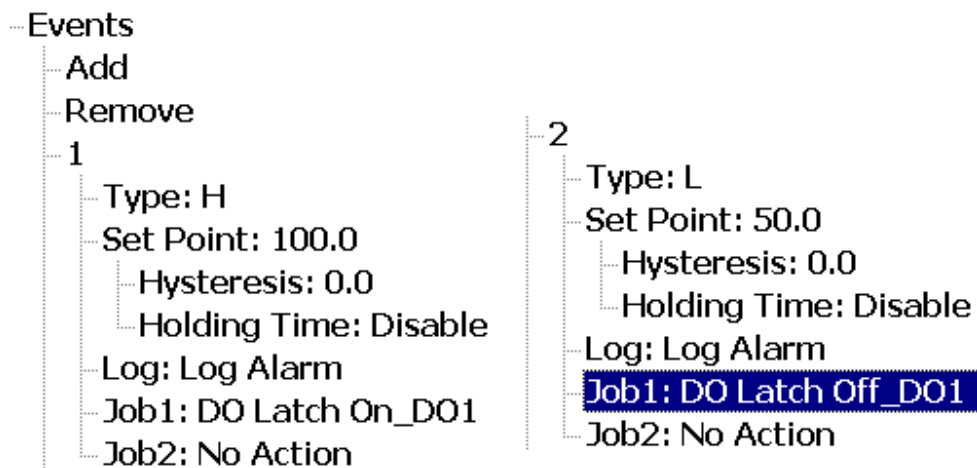

Figure 4-27. Event Configuration Example

4.3.1.1.4 Sample Configuration of Process Control Card

4.3.1.1.4.1 Heat Only ON-OFF Control

Select REVR for OUT1, Set PB1 to 0, SP1 is used to adjust set point value, O1HY is used to adjust dead band for ON-OFF control, TIME is used to adjust the dwell timer (enabled by

selecting TIMR for A1FN or A2FN). The output 1 hysteresis (O1HY) is enabled in case of PB1 = 0. The heat only on-off control function is shown in the following diagram.

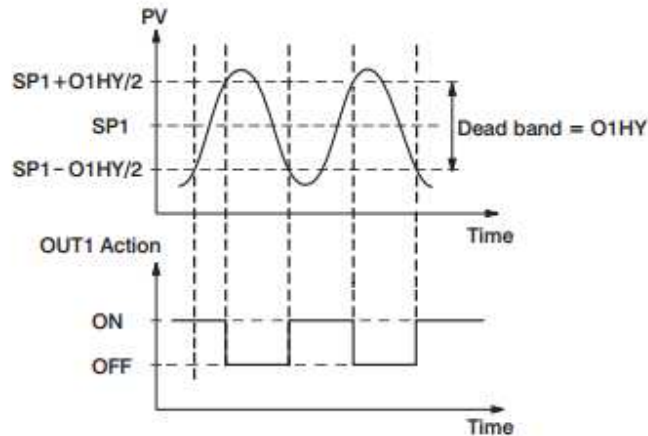

Figure 4-28. Heat Only ON-OFF Control

The ON-OFF control may introduce excessive process oscillation even if Hysteresis is minimized to the smallest. If ON-OFF control is set (i.e. PB1 = 0), TI1, TD1, CYC1, OFST, CPB and PL1 will be hidden and have no function to the system. The manual mode, auto-tuning, self-tuning and bumpless transfer will be disabled too.

Select REVR for OUT1, set TI1 to 0, SP1 is used to adjust set point value, TIME is used to adjust the dwell timer (enabled by selecting TIMR for A1FN or A2FN). OFST been enabled in case of TI1 = 0 is used to adjust the control offset (manual reset). Adjust CYC1 according to

The output 1 type (O1TY). Generally, CYC1= 0.5 ~ 2 sec for SSRD and SSR, CYC1=10 ~ 20 sec for relay output .CYC1 is ignored if linear output is selected for O1TY. If PB1 is not equal to 0.

OFST is measured by % with range 0 - 100.0 %. In the steady state (i.e. process has been stabilized) if the process value is lower than the set point a definite value, say 5 C, while 20 C is used for PB1, that is lower 25 %, then increase OFST 25 %, and vice versa. After adjusting OFST value, the process value will be varied and eventually, coincide with set point.

Using the P control (TI1 set to 0), the auto-tuning and self-tuning are disabled. Manual reset (adjust OFST) is not practical because the load may change from time to time and often need to adjust OFST repeatedly. The PID control can avoid this situation. Selecting REVR for OUT1, SP1 is used to adjust set point value.

TIME is used to adjust the dwell timer (enabled by selecting TIMR for A1FN or A2FN). PB1 and TI1 should not be zero. Adjust CYC1 according to the output 1 type (O1TY). Generally, CYC1 = 0.5 ~ 2 sec for SSRD and SSR, CYC1 = 10 ~ 20 sec for relay output. CYC1 is ignored if linear output is selected for O1TY.

In most cases the self-tuning can be used to substitute the auto-tuning. See If self-tuning is not used (select NONE for SELF), then use auto-tuning for the new process, or set PB1, TI1 and TD1 with historical values. If the control result is still unsatisfactory, then use manual tuning to

improve the control .This Process Control Card contains a very clever PID and Fuzzy algorithm to achieve a very small overshoot and very quick response to the process if it is properly tuned.

4.3.1.1.4.2 Cool Only ON-OFF Control

ON-OFF control, P (PD) control and PID control can be used for cool control. Set OUT1 to DIRT (direct action). The other functions for cool only ON-OFF control, cool only P(PD) control and cool only PID control are same as Heat only ON-OFF Control except that the output variable (and action) for the cool control is inverse to the heat control, such as the following diagram shows:

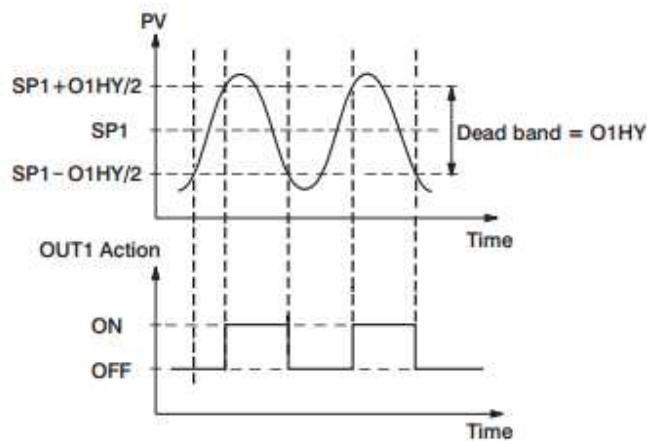

Figure 4-29.Cool Only ON-OFF Control

4.3.1.1.4.3 Heat Cool Control

The Heat-Cool Control can use one of 6 combinations of control modes. Setups of Parameters for each control mode are shown in the following table.

Control Modes	Heat Uses	Cool Uses	Setup Values											
			OUT1	OUT2	O1HY	OFST	PB1	T11	TD1	CPB	DB	A1FN or A2FN	A1MD or A2MD	A1HY or A2HY
Heat : ON-OFF Cool : ON-OFF	OUT1	ALM1 or ALM2	REVR	NONE	☆	×	=0	×	×	×	×	DE.HI or PV1.H	NORM	☆
Heat : ON-OFF Cool : P (PD)	ALM1 or ALM2	OUT1	DIRT	NONE	×	☆	≠0	=0	☆	×	×	DE.LO or PV1.L	NORM	☆
Heat : ON-OFF Cool : PID	ALM1 or ALM2	OUT1	DIRT	NONE	×	×	≠0	≠0	☆	×	×	DE.LO or PV1.L	NORM	☆
Heat : P (PD) Cool : ON-OFF	OUT1	ALM1 or ALM2	REVR	NONE	×	☆	≠0	=0	☆	×	×	DE.HI or PV1.H	NORM	☆
Heat : PID Cool : ON-OFF	OUT1	ALM1 or ALM2	REVR	NONE	×	×	≠0	≠0	☆	×	×	DE.HI or PV1.H	NORM	☆
Heat : PID Cool : PID	OUT1	OUT2	REVR	COOL	×	×	≠0	≠0	☆	☆	☆	×	×	×

Table 4-41.Heat Cool Control Modes

- × : Don't care
- ☆ : Adjust to meet process requirements

Note

The ON-OFF control may result excessive overshoot and undershoot problems in the process. The P (or PD) control will result in a deviation process value from the set point. It is recommended to use PID control for the Heat-Cool control to produce a stable and zero offset process value.

Other Setup Required

O1TY, CYC1, O2TY, CYC2, A2SP, A2DV, O1TY & O2TY are set in accordance with the types of OUT1 & OUT2 installed. CYC1 & CYC2 are selected according to the output 1 type (O1TY) & output 2 type (O2TY). Generally, selects 0.5 ~ 2 sec. for CYC1, if SSRD or SSR is used for O1TY; 10 ~ 20 sec. if relay is used for O1TY, and CYC1 is ignored if linear output is used. Similar condition is applied for CYC2 selection.

Examples

- ❖ Heat PID+Cool ON-OFF: Set OUT1= REVR, A1FN or A2FN= PV1.H, A1FN or A2MD=NORM, A1HY or A2HY=0.1, PB1=0, T11=0, TD1=0, and set appropriate values for O1TY and CYC1.

- ❖ Heat PID+Cool PID: set OUT1=REVR, OUT2=COOL, CPB=100, DB=-4.0, PB1=0, TI1=0, TD1=0, and set appropriate values for O1TY, CYC1, O2TY, and CYC2.

CPB Programming

The cooling proportional band is measured by % of PB with range 1~255. Initially set 100% for CPB and examine the cooling effect. If cooling action should be enhanced then decrease CPB .If cooling action is too strong then increase CPB. The value of CPB is related to PB and its value remains unchanged throughout the self-tuning and auto-tuning procedures.

Adjustment of CPB is related to the cooling media used. For air is used as cooling media, adjust CPB at 100(%). For oil is used as cooling media, adjust CPB at 125(%). For water is used as cooling media, adjust CPB at 250(%)

DB Programming

Adjustment of DB is dependent on the system requirements. If more positive value of DB (greater dead band) is used, an unwanted cooling action can be avoided but an excessive overshoot over the set point will occur. If more negative value of DB (greater overlap) is used, an excessive overshoot over the set point can be minimized but an unwanted cooling action will occur. It is adjustable in the range -36.0% to 36.0 % of PB1 (or PB2 if PB2 is selected). A negative DB value shows an overlap area over which both outputs are active. A positive DB value shows a dead band area over which neither output is active

4.3.1.1.4.4 Heater Break Alarm

A current transformer CT94-1 should be installed to detect the heater current if a heater break alarm is required. The CT signal is sent to input 2, and the PV2 will indicate the heater current in 0.1 Amp. Resolution. The range of current transformer is 0 to 50.0 Amps.

Example

A furnace uses two 2KW heaters connected in parallel to warm up the process. The line voltage is 220V and the rating current for each heater is 9.09A. If we want to detect any one heater break, set A1SP=13.0A, A1HY=0.1 A1FN=PV2.L, A1MD=NORM, then

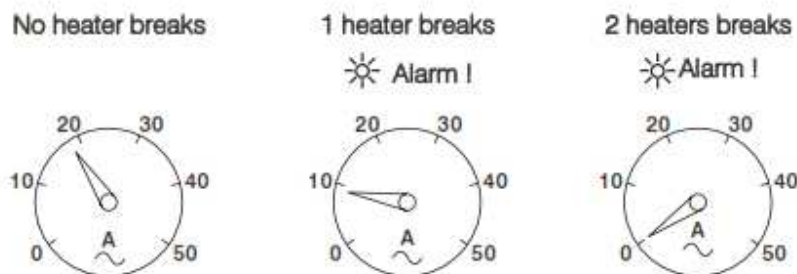

Figure 4-30. Heater Break Alarm

4.3.1.1.4.5 Loop Break Alarm

A1FN selects LB if alarm 1 is required to act as a loop break alarm. Similarly, if alarm 2 is required to act as a loop break alarm, then set OUT2 with=AL2 and A1FN with LB.

TIME, A1SP, A1DV and A1HY are hidden if alarm 1 is configured as a loop break alarm. Similarly, TIME, A2SP, A2DV and A2HY are hidden if alarm 2 is configured as a loop break alarm.

One of 4 kinds of alarm modes can be selected for alarm 1 and alarm 2. These are: Normal alarm, latching alarm, Holding alarm and Latching/Holding alarm. However, the Holding mode and latching/Holding mode are not recommended to be chosen for loop break alarm since loop break alarm will not perform holding function even if it is set with holding or latching/holding mode.

Loop Break Conditions are detected during a time interval of 2T11 (double of integral time, but 120 seconds maximum). Hence the loop break alarm doesn't respond quickly as it occurs. If the process value doesn't increase (or decrease) while the control variable MV1 has reached to its maximum (or minimum) value within the detecting time interval, a loop break alarm (if configured) will be actuated.

Loop Break Alarm (if configured) occurs when any following condition happens

- ❖ Input sensor is disconnected (or broken).
- ❖ Input sensor is shorted.
- ❖ Input sensor is defective.
- ❖ Input sensor is installed outside (isolated from) the process.
- ❖ Controller fails (A-D converter damaged).
- ❖ Heater (or generally, chiller, valve, pump, motor etc.) breaks or fails or uninstalled
- ❖ Switching device (used to drive heater) is open or shorted.

4.3.1.1.4.6 Sensor Break Alarm

Alarm 1 or alarm 2 can be configured as sensor break alarm by selecting SENB for A1FN or A2FN. The sensor break alarm is activated as soon as failure mode occurs. Note that A-D failure also creates a sensor break alarm. TIME, A1SP, A1DV, and A1HY are hidden if alarm 1 is configured as a sensor break alarm. Similarly, TIME, A2SP, A2DV and A2HY are hidden if alarm 2 is configured as a sensor break alarm.

One of 4 kinds of alarm modes can be selected for sensor break alarm. These are: Normal alarm, latching alarm, Holding alarm and Latching/Holding alarm. However, the Holding alarm and Latching/Holding alarm are not recommended to be chosen for sensor break alarm since sensor break alarm will not perform holding function even if it is set with holding or latching/holding mode.

4.3.1.1.4.7 Failure Transfer

The controller will enter failure mode as one of the following conditions occurs.

- ❖ SB1E Error occurs (due to the input 1 sensor break or input 1 current below 1mA,if 4-20 mA is selected or input 1 voltage below 0.25V if 1-5 V is selected), if PV1, P1-2 or P2-1 is selected for PVMD or PV1 is selected for SPMD.
- ❖ SB2E Error occurs (due to the input 2 sensor break or input 2 current below 1mA,if 4-20 mA is selected or input 2 voltage below 0.25V if 1-5 V is selected), if PV2, P1-2 or P2-1 is selected for PVMD or PV2 is selected for SPMD.
- ❖ ADER Error occurs due to the A-D converter of the controller fails.

The output 1 and output 2 will perform the function as one of the following conditions occurs.

- ❖ During power starts (within 2.5 seconds).
- ❖ The controller enters the failure mode.
- ❖ The controller enters the manual mode.
- ❖ The controller enters the calibration mode.

Output 1 Failure Transfer, if activated, will perform

- ❖ If output 1 is configured as proportional control ($PB1 \neq 0$), and BPLS selected for O1FT, then output 1 will perform bumpless transfer. Thereafter the previous averaging value of MV1 will be used for controlling output 1.
- ❖ If output 1 is configured as proportional control ($PB1 \neq 0$), and a value of 0 to 100.0 % is set for O1FT, then output 1 will perform failure transfer. Thereafter the value of O1FT will be used for controlling output 1.
- ❖ If output 1 is configured as ON-OFF control ($PB1 = 0$), then output 1 will be driven OFF if O1FN selects REVR and be driven ON if O1FN selects DIRT.
- ❖ If output 1 is configured as ON-OFF control ($PB1=0$), then output 1 will be driven OFF if O1FN selects REVR and be driven ON if O1FN selects DIRT.

Output 2 Failure Transfer, if activated, will perform

- ❖ If OUT2 selects COOL, and BPLS is selected for O1FT, then output 2 will perform bumpless transfer. Thereafter the previous averaging value of MV2 will be used for controlling output 2.
- ❖ If OUT2 selects COOL, and a value of 0 to 100.0 % is set for O2FT, then output 2 will perform failure transfer. Thereafter the value of O1FT will be used for controlling output 2.

Alarm 1 Failure Transfer is activated as the controller enters failure mode. Thereafter the alarm 1 will transfer to the ON or OFF state preset by A1FT.

Exception: If Loop Break (LB) alarm or sensor Break (SENB) alarm is configured for A1FN, the alarm 1 will be switched to ON state independent of the setting of A1FT. If Dwell Timer (TIMR) is configured for A1FN, the alarm 1 will not perform failure transfer.

Alarm 2 Failure Transfer is activated as the controller enters failure mode. Thereafter the alarm 2 will transfer to the ON or OFF state preset by A2FT. Alarm 2 Failure Transfer is activated as the controller enters failure mode.

Exception: If Loop Break (LB) alarm or sensor Break (SENB) alarm is configured for A2FN, the alarm 2 will be switched to ON state independent of the setting of A2FT. If Dwell Timer (TIMR) is configured for A2FN, the alarm 2 will not perform failure transfer.

4.3.1.1.4.8 Bumpless Transfer

The bumpless transfer function is available for output 1 and output 2 (provided that OUT2 is configured as COOL).

Bumpless Transfer is enabled by selecting BPLS for O1FT and/or O2FT and activated as one of the following cases occurs.

- ❖ Power starts (within 2.5 seconds).
- ❖ The controller enters the failure mode.
- ❖ The controller enters the manual mode.
- ❖ The controller enters the calibration mode.

As the bumpless transfer is activated, the controller will transfer to open-loop control and uses the previous averaging value of MV1 and MV2 to continue control.

Without Bumpless Transfer

Since the hardware and software need time to be initialized, the control is abnormal as the power is recovered and results in a large disturbance to the process. During the sensor breaks, the process loses power.

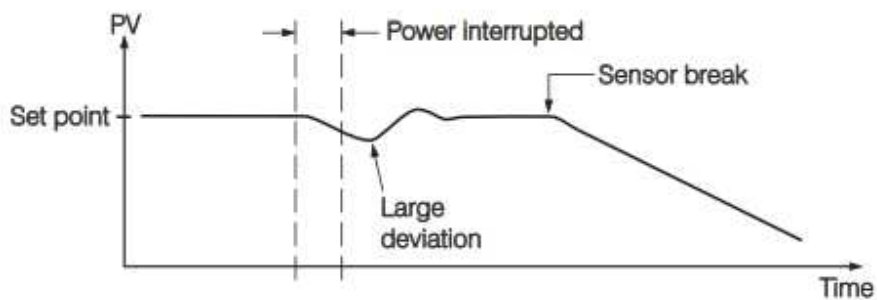

Figure 4-31. Without Bumpless Transfer

Without Bumpless Transfer

After bumpless transfer is configured with the correct control variables applied, the disturbance is small when the power is recovered. During the sensor breaks, the controller

continues to control by using its previous value. If the load doesn't change, the process will remain stable. Thereafter, once the load changes, the process may run away. Therefore, the user should not rely on a bumpless transfer for a longer time. For fail safe reason, an additional alarm should be used to announce the operator when the system fails. For ,a Sensor Break Alarm, if configured, will switch to failure state and announces the operator to use manual control or take a proper security action when the system enters failure mode.

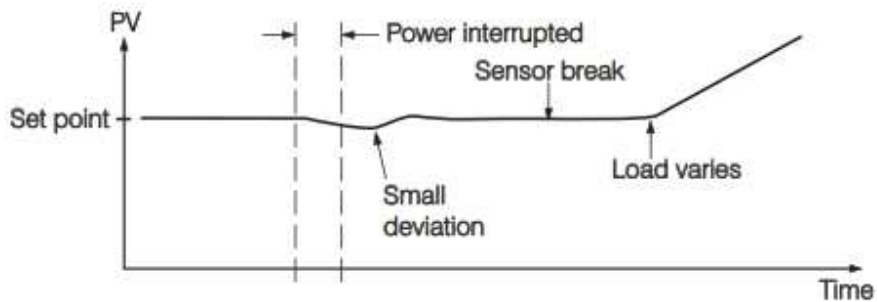

Figure 4-32. With Bumpless Transfer

Warning: After system fails, never depend on bumpless transfer for a long time; otherwise it might cause a problem to the system to run away.

4.3.1.1.4.9 PV1 Shift

In certain applications it is desirable to shift the controller display value from its actual value. This can be easily accomplished by using the PV1 shift function. Press the "scroll " key to the parameter SHIF in card parameter. The value you adjust here, either positive or negative, will be added to the actual value. The SHIF function will alter PV1 only.

Here is an example. A process is equipped with a heater, a sensor and a subject to be warmed up. Due to the design and position of the components in the system, the sensor could not be placed any closer to the part. Thermal gradient (different temperature) is common and necessary to an extent in any thermal system for heat to be transferred from one point to another. If the difference between the sensor and the subject is 35 C, and the desired temperature at the subject to be heated is 200 C, the controlling value or the temperature at the sensor should be 235 C. You should input -35 C as to subtract 35 C from the actual process display. This in turn will cause the controller to energize the load and bring the process display up to the set point value

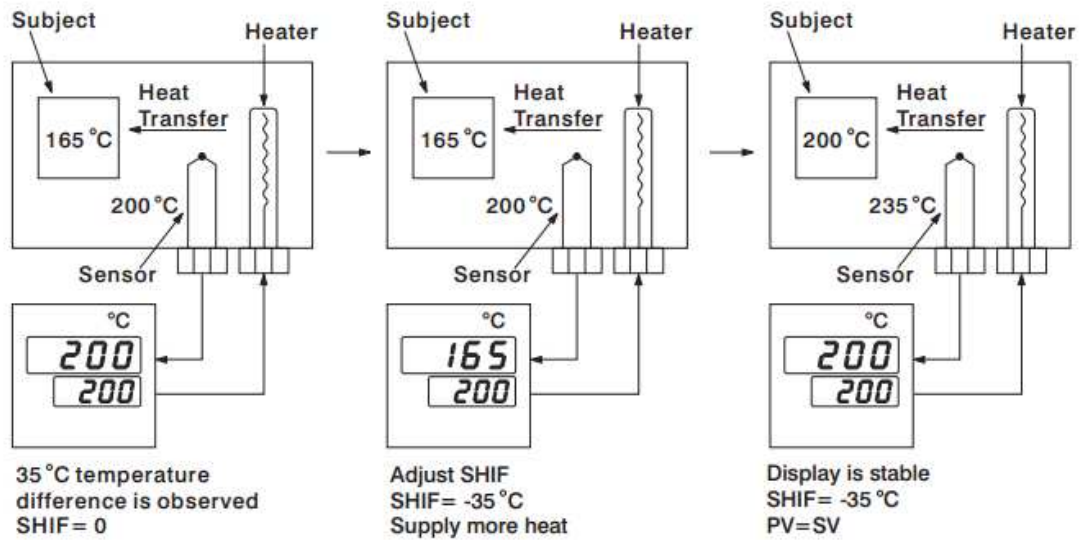

Figure 4-33.PV1 SHIFT Application

4.3.1.1.4.10 SP1 Range

SP1L (SP1 low limit value) and SP1H (SP1 high limit value) in setup menu are used to confine the adjustment range of SP1.

Example: A freezer is working in its normal temperature range -10 C to -15 C. In order to avoid an abnormal set point, SP1L and SP1H are set with the following values:

SP1L = -15 C SP1H = -10 C

Now SP1 can only be adjusted within the range from -10 C to -15 C.

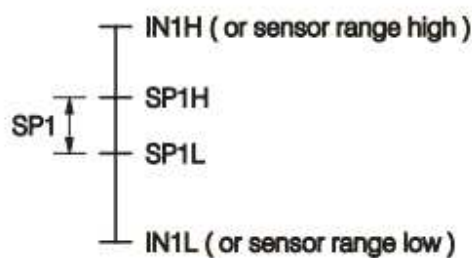

Figure 4-34.SP1 Range

4.3.1.1.4.11 Dwell Timer

Alarm 1 or alarm 2 can be configured as dwell timer by selecting TIMR for A1FN or A2FN, but not both, otherwise Error will appear. As the dwell timer is configured, the parameter TIME is used for dwell time adjustment. The dwell time is measured in minute ranging from 0 to 6553.5 minutes. Once the process reaches the set point the dwell timer starts to count from zero until time

out. The timer relay will remain unchanged until time out. The dwell timer operation is shown as following diagram.

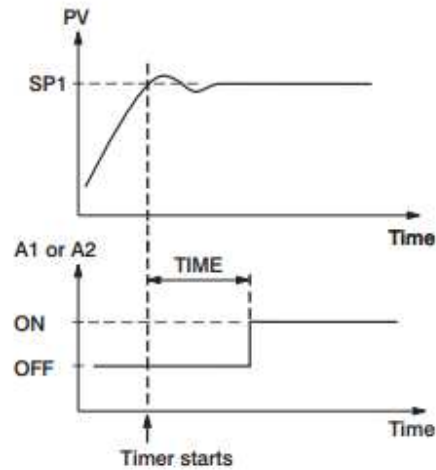

Figure 4-35.Dwell Timer

If alarm 1 is configured as dwell timer, A1SP, A1DV, A1HY and A1MD are hidden. Same case is for alarm 2.

Example

Set A1FN=TIMR or A2FN=TIMR but not both. Adjust TIME in minutes .A1MD (if A1FN=TIMR) or A2MD (if A2FN=TIMR) is ignored in this case.

4.3.1.1.4.12 Process Alarms

A process alarm sets an absolute trigger level (or temperature). When the process (could be PV1, PV 2 or PV1-PV2) exceeds that absolute trigger level an alarm occurs. A process alarm is independent from set point. Adjust A1FN (Alarm 1 function) in setup menu. One of 8 functions can be selected for process alarm. These are: **PV1.H, PV1.L, PV2.H, PV2.L, P1.2.H,**

P1.2.L, D1.2.H, D1.2.L.

When the PV1.H or PV1.L is selected the alarm examines the PV1 value. When the PV2.H or PV2.L is selected the alarm examines the PV2 value.

When the P1.2.H or P1.2.L is selected the alarm occurs if the PV1 or PV2 value exceed the trigger level. When the D1.2.H or D1.2.L is selected the alarm occurs if the PV1-PV2 (difference) value exceeds the trigger level. The trigger level is determined by A1SP (Alarm 1 set point) and A1HY (Alarm 1 hysteresis value) in configuration for alarm 1. The hysteresis value is introduced to avoid interference action of alarm in a noisy environment. Normally A1HY can be set with a minimum (0.1) value. A1DV and/or A2DV are hidden if alarm 1 and/or alarm 2 are set with process alarm.

Normal Alarm: A1MD = NORM

When a normal alarm is selected, the alarm output is de-energized in the non-alarm condition and energized in an alarm condition.

Latching Alarm: A1MD = LTCH

If a latching alarm is selected, once the alarm output is energized, it will remain unchanged even if the alarm condition is cleared. The latching alarms are disabled when the power is shut off or if event input is applied with proper selection of EIFN.

Holding Alarm: A1MD = HOLD

A holding alarm prevents an alarm from power up. The alarm is enabled only when the process reaches the set point value (may be SP1 or SP2). Afterwards, the alarm performs same function as normal alarm.

Latching / Holding Alarm: A1MD = LT .HO

A latching / holding alarm performs both holding and latching function.

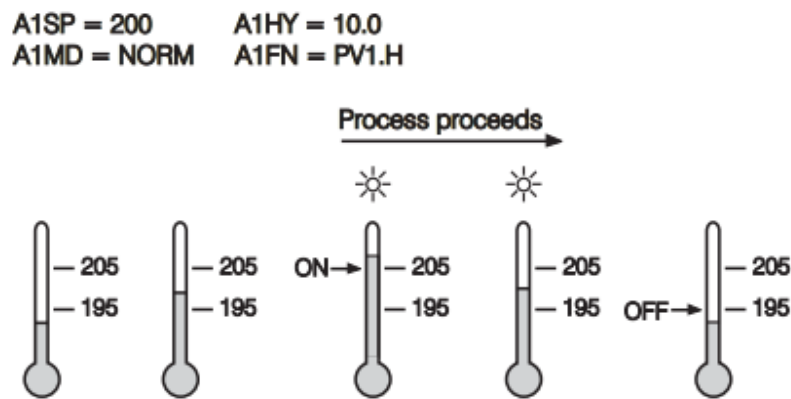

Figure 4-36. Normal Process Alarm

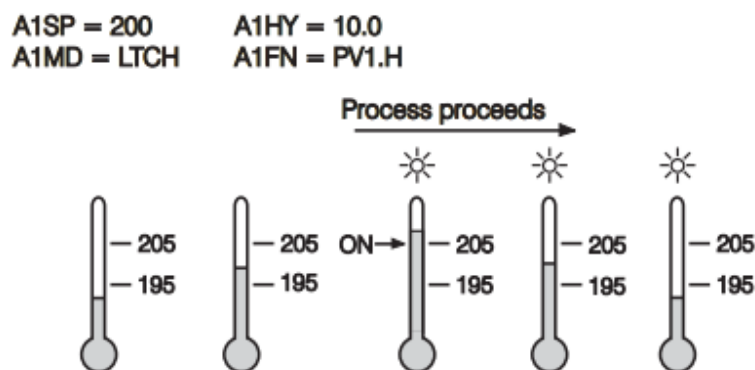

Figure 4-37. Latching Process Alarm

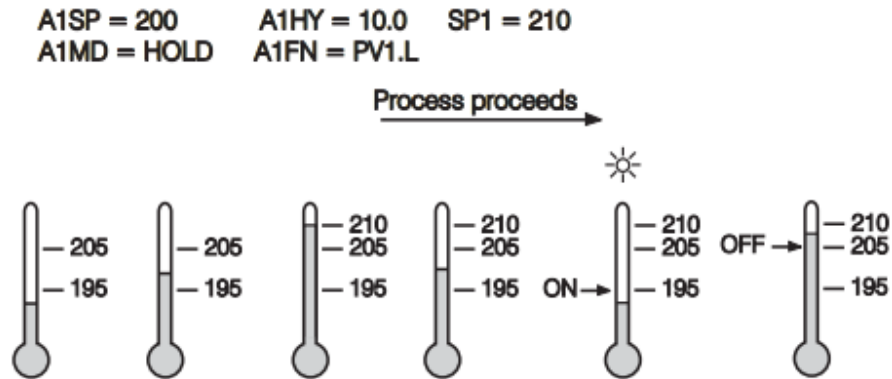

Figure 4-38.Holding Process Alarm

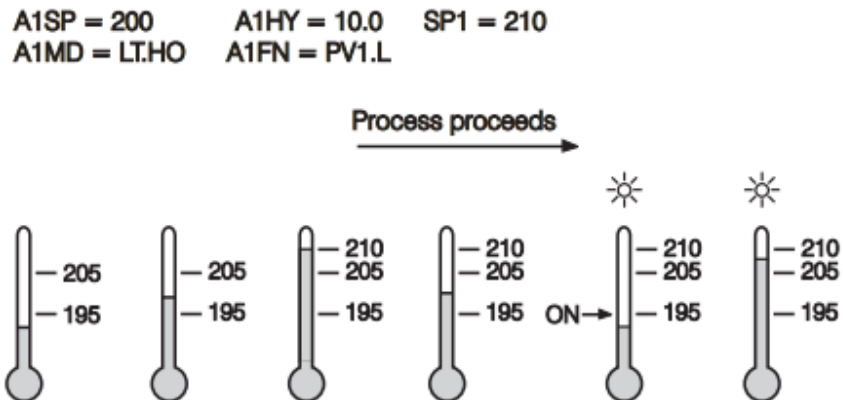

Figure 4-39.Latching / Holding Process Alarm

Although the above descriptions are based on alarm 1, the same conditions can be applied to alarm 2.

4.3.1.1.4.13 Deviation Alarm

A deviation alarm alerts the user when the process deviates too far from set point. The user can enter a positive or negative deviation value (A1DV, A2DV) for alarm 1 and alarm 2. A hysteresis value (A1HY or A2HY) can be selected to avoid interference problem of alarm in a noisy environment. Normally, A1HY and A2HY can be set with a minimum (0.1) value.

Trigger levels of alarm are moving with set point.

For alarm 1, Trigger levels=SP1+A1DV 1/2 A1HY.

For alarm 2, Trigger levels=SP1+A2DV 1/2 A2HY.

A1SP and/or A2SP are hidden if alarm 1 and/or alarm 2 are set with deviation alarm. One of 4 kinds of alarm modes can be selected for alarm 1 and alarm 2. These are Normal alarm, latching alarm, Holding alarm and Latching/Holding alarm.

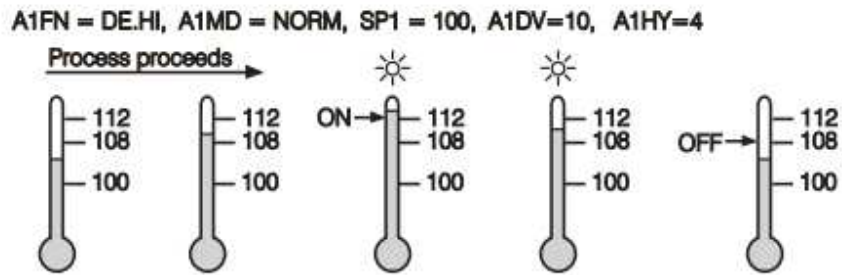

Figure 4-40.Normal Deviation Alarm

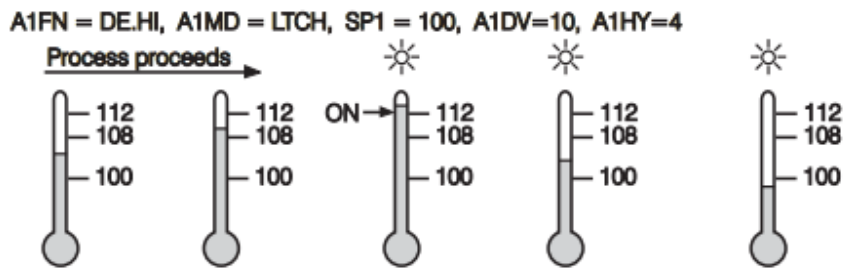

Figure 4-41.Latching Deviation Alarm

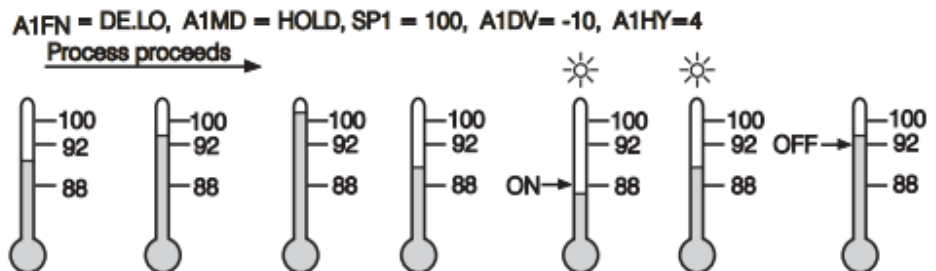

Figure 4-42.Holding Deviation Alarm

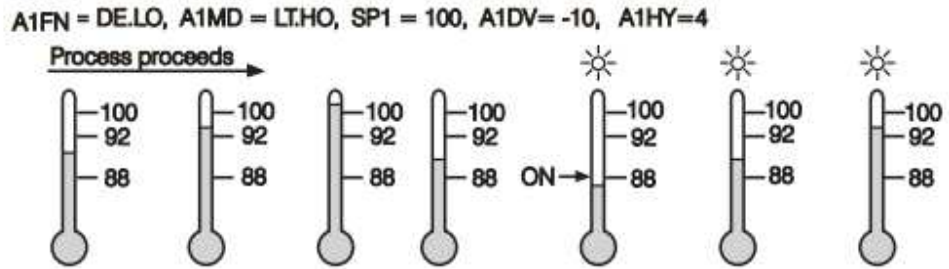

Figure 4-43. Latching/Holding Deviation Alarm

4.3.1.1.4.14 Deviation Band Alarm

A deviation band alarm presets two reference levels relative to set point. Two types of deviation band alarm can be configured for alarm 1 and alarm 2. These are deviation band high alarm (A1FN or A2FN select DB.HI) and deviation band low alarm (A1FN or A2FN select DB.LO). A1SP and A1HY are hidden if alarm 1 is selected with deviation band alarm. Similarly, A2SP and A2HY are hidden if alarm 2 is selected with deviation band alarm. Trigger levels of deviation band alarm are moving with set point. For alarm 1, trigger levels = $SP1 \pm A1DV$. For alarm 2, trigger levels = $SP1 \pm A2DV$. One of 4 kinds of alarm modes can be selected for alarm 1 and alarm 2. These are Normal alarm, latching alarm, Holding alarm and Latching/Holding alarm.

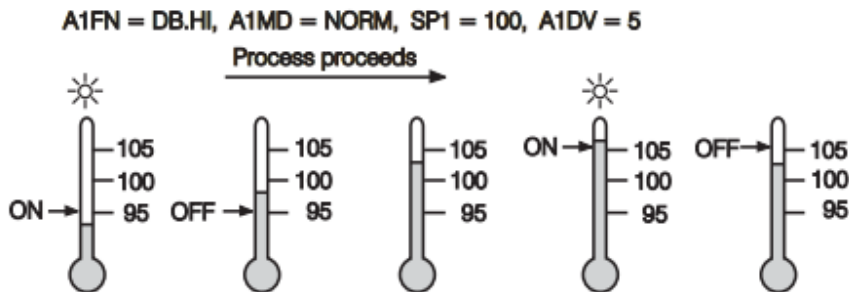

Figure 4-44. Normal Deviation Band Alarm

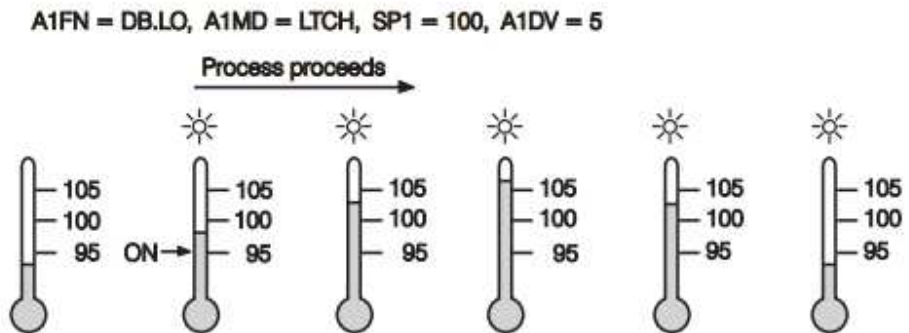

Figure 4-45.Latching Deviation Band Alarm

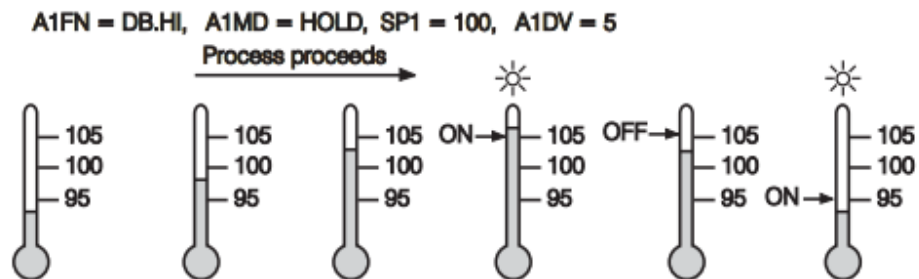

Figure 4-46.Holding Deviation Band Alarm

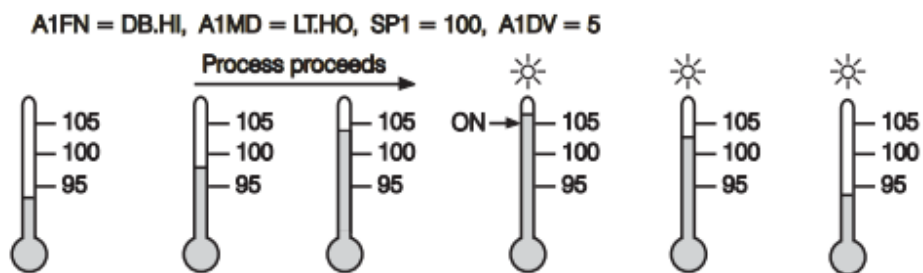

Figure 4-47.Latching/Holding Deviation Band Alarm

4.3.1.1.4.15 Event Input

The Event input accepts a digital type signal. Three types of signals can be connected to event input. These are

- ❖ Relay or switch contacts
- ❖ Open collector pull low

❖ TTL logic level

❖

One of ten available functions can be chosen by using (EIFN) contained in setup menu.

❖ **NONE:** Event input No function. If chosen, the event input function is disabled. The controller will use PB1, TI1 and TD1 for PID control and SP1 (or other values determined by SPMD) for the set point.

❖ **SP2:** If chosen, the SP2 will replace the role of SP1 for control. SP2: If chosen, the SP2 will replace the role of SP1 for control.

❖ **PID2:** If chosen, the second PID set PB2, TI2 and TD2 will be used to replace PB1, TI1 and TD1 for control.

❖ **PID2:** If chosen, the second PID set PB2, TI2 and TD2 will be used to replace PB1, TI1 and TD1 for control.

❖ **SP.P2:** If chosen, the SP2, PB2, TI2 and TD2 will replace SP1, PB1, TI1 and TD1 for c

❖

❖ **NOTE:** If the second PID set is chosen during Auto-tuning and/or Self-tuning procedures, the new PID values will be stored in PB2, TI2 and TD2.

❖

❖ **RS.A1:** Reset Alarm 1 as the event input is activated. However, if alarm 1 condition is still existent, the alarm 1 will be retriggered again while the event input is released.

❖ **RS.A2:** Reset Alarm 2 as the event input is activated. However, if alarm 2 conditions are still existent, the alarm 2 will be retriggered again while the event input is released.

❖ **R.A1.2:** Reset both Alarm 1 and Alarm 2 as the event input is activated. However, if the alarm 1 and/or alarm 2 are still existent, the alarm 1 and/or alarm 2 will be triggered again while the event input is released.

❖ The **RS.A1**, **RS.A2** and **R.A1.2** are particularly suitable to be used for a Latching and/or Latching/Holding alarms.

❖ **D.O1:** Disable Output 1 as the event input is activated. The output 1 control variable MV1 is cleared to zero.

❖ **D.O2:** Disable Output 2 as the event input is activated. The output 2 control variables MV2 is cleared to zero.

❖ **D.O1.2:** Disable both Output 1 and Output 2 by clearing MV1 and MV2 values as soon as the event input is activated.

❖

- ❖ When any of D.O1, D.O2 or D.O1.2 is selected for EIFN, the output 1 and/or output 2 will revert to their normal conditions as soon as the event input is released.



- ❖ **LOCK:** All parameters are locked to prevent from being changed.

- ❖ **SP2F Function:** Define format of SP2 value. If SP2F in the setup menu is selected with ACTU, the event input function will use SP2 value for its second set point. If SP2F is selected with DEVI, the SP1 value will be added to SP2. The sum of SP1 and SP2 (SP1+SP2) will be used by the event input function for the second set point value. In certain applications it is desirable to move second set point value with respect to set point 1 value. The DEVI function for SP2 provides a convenient way in this case.



4.3.1.1.4.16 Second Set Point

In certain applications it is desirable to change the set point automatically without the need to adjust the set point. You can apply a signal to event input terminals. The signal applied to event input may come from a Timer, a PLC, and an Alarm Relay, a Manual switch or other devices. Select SP2 for EIFN which is contained in setup menu. This is available only with the case that SP1.2, MIN.R or HR.R is used for SPMD, where MIN.R and HR.R are used for the ramping function.

Application 1: A process is required to be heated at a higher temperature as soon as its pressure exceeds a certain limit. Set SPMD=SP1.2, EIFN=SP2 (or SP .P2 if the second PID is required for the higher temperature too). The pressure gauge is switched ON as it senses a higher pressure. Connect the output contacts of the pressure gauge to the event input. SP1 is set with a normal temperature and SP2 is set with a higher temperature. Choose ACTU for SP2F.

Application 2: An oven is required to be heated at 300°C from 8.00 AM to 6.00 PM After 6.00 PM it is desirable to be maintained at 80°C. Use a programmable 24 hours cycle timer for this purpose. The timer output is used to control event input. Set SPMD=SP1.2, and EIFN=SP2 (or SP .P2 if the second PID is required to be used for the second set point). SP1 is set with 300°C and SP2 is set with 80°C. Choose ACTU for SP2F. After 6.00 PM the timer output is closed. The event input function will select SP2 (=80°C) to control the process.

4.3.1.1.4.17 Second PID Set

In certain applications the process characteristics is strongly related to its process value. The Process Control Card provides two set of PID values. When the process is changed to different set point, the PID values can be switched to another set to achieve an optimum condition.

The optimal PID values for a process may vary with its process value and set point. Hence if a process is used for a wide range of set point, dual PID values are necessary to optimize the control performance. If the first PID set is selected (event input is not applied) during auto-tuning procedure, the PID values will be stored in PB1, TI1 and TD1. Similarly, if the second PID set is selected (event input is applied while PID2 or SP.P2 is selected for EIFN) during auto-tuning, the PID values will be stored in PB2, TI2 and TD2 as soon as auto-tuning is completed.

Application 1: Programmed by Set Point

Choose SP.P2 for EIFN then both set point and PID values will be switched to another set simultaneously. The signal applied to event input may come from a Timer, a PLC, an Alarm Relay, a Manual Switch or other devices.

Application 2: Programmed by Process Value

If the process value exceeds a certain limit, 500°C for example, it is desirable to use another PID values to optimize the control performance. The user can use a process high alarm to detect the limit of the process value. Choose PV1H for A1FN, A1MD selects NORM, adjust A1SP to be equal to 500° C, and choose PID2 for EIFN. If the temperature is higher than 500°C, then alarm 1 is activated. The alarm 1 output is connected to event input; the PID values will change from PB1, TI1 and TD1 to PB2, TI2 and TD2.

4.3.1.1.4.18 Ramp & Dwell

Ramp

The ramping function is performed during power up as well as any time the set point is changed. Choose MINR or HRR for SPMD, the unit will perform the ramping function. The ramp rate is programmed by using RAMP which is available in user configuration of Process Control Card

Example without Dwell Timer

Select MINR for SPMD, IN1U selects °C, DP1 selects 1-DP, Set RAMP=10.0. SP1 is set to 200°C initially, and changed to 100°C after 30 minutes since power up. The starting temperature is 30° C. After power up the process is running like the curve shown below

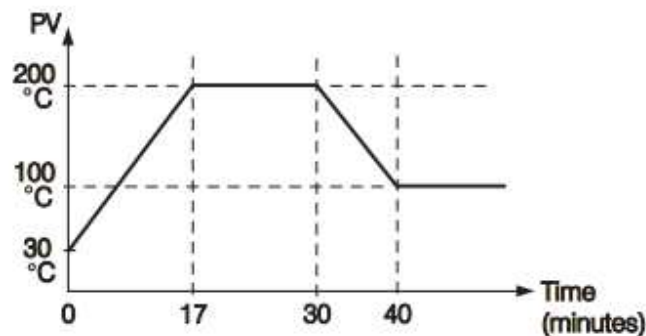

Figure 4-48.Ramp Function

Note: When the ramp function is used, the lower display will show the current ramping value. However it will revert to show the set point value as soon as the up or down key is touched for adjustment. The ramping value is initiated to process value either power up or RAMP and /or set point are changed. Setting RAMP to zero means no ramp function at all.

Dwell

The Dwell timer can be used separately or accompanied with a Ramp. If A1FN selects TIMR, the alarm 1 will act as a dwell timer. Similarly, alarm 2 will act as a dwell timer if A2FN selects TIMR.

The timer is programmed by using TIME which is contained in Configuration menu. The Timer starts to count as soon as the process reaches its set point, and triggers an alarm as time out. Here is an example.

Example without Dwell Timer

Select TIMR for A1FN, IN1U selects F, DP1 selects NODP, Set TIME=30.0 SP1 is set to 400 F initially, and corrected to 200 F before the process reaches 200° F. As the process reaches set point (i.e. 200° F) the timer starts to count. The TIME value can still be corrected without disturbing the Timer before time out. The TIME is changed to 40.0 after 28 minutes since the process reached its set point. The behavior of process value and alarm 1 are shown below.

Once the timer output was energized it will remain unchanged until power down or an event input programmed for resetting alarm is applied.

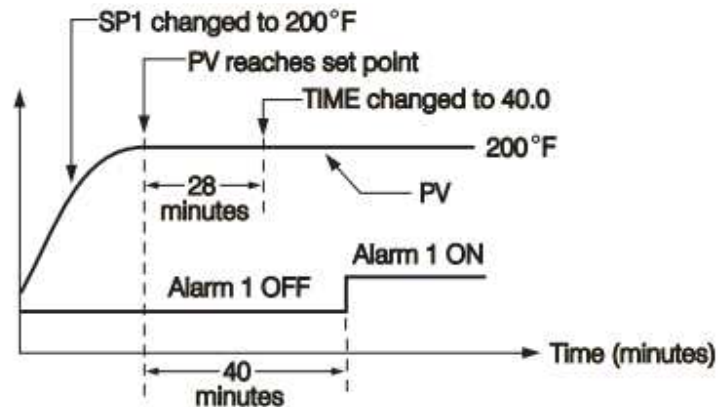

Figure 4-49.Dwell Timer

Note: The TIMR can't be chosen for both A1FN and A2FN simultaneously; otherwise an error code will produce.

Ramp & Dwell

A Ramp can be accompanied with a dwell timer to control the process. Here is an example.

Example Ramp & Dwell Timer

Select HRR for SPMD, IN1U selects PU, DP1 select 2-DP, Set RAMP=60.00 A2FN selects TIMR, Set TIME=20.0 as power is applied the process value starts from 0.00 and set SP1=30.00, SP2=40.00. The timer output is used to control event input.

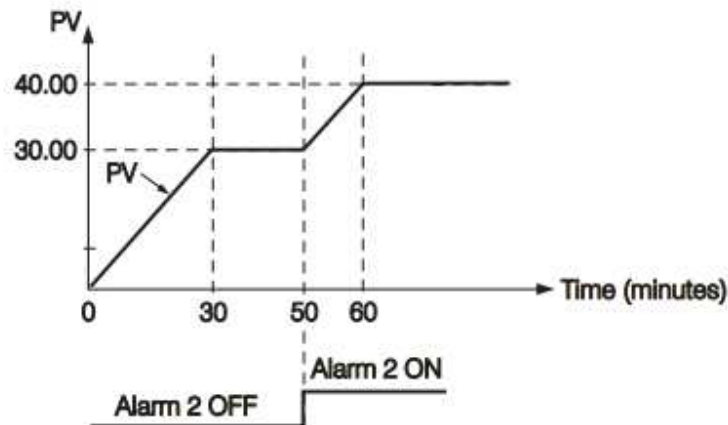

Figure 4-50. Ramp Accompanied with Dwell Timer

4.3.1.1.4.19 Remote Set Point

SPMD selecting PV1 or PV2 will enable the Process Control Card to accept a remote set point signal. If PV1 is selected for SPMD, the remote set point signal is sent to Input 1, and Input 2 is used for process signal input. If PV2 is selected for SPMD, the remote set point signal is sent to Input 2, and Input 1 is used for process signal. To achieve this, set the following parameters in the Configuration menu.

Case 1: Use Input 2 to accept remote set point

FUNC=FULL

IN2, IN2U, DP2, IN2L, IN2H, are set according to remote signal.

PVMD=PV1

IN1, IN1U, DP1, are set according to the process signal

IN1L, IN1H if available, are set according to the process signal

SPMD= PV2

Case 2: Use Input 1 to accept remote set point

FUNC=FULL

IN1, IN1U, DP1, IN1L, IN1H, are set according to remote signal.

PVMD=PV2

IN2, IN2U, DP2, are set according to the process signal

IN2L, IN2H if available, are set according to the process signal

SPMD= PV1

Note: If PV1 are chosen for both SPMD and PVMD, an Error Code will appear. If PV2 are chosen for both SPMD and PVMD, an Error Code will appear. The user should not use these cases, otherwise, the Process Control Card will not control properly.

4.3.1.1.4.20 Differential Control

In certain applications it is desirable to control second process such that its process value always deviates from the first process with a constant value. To achieve this, set the following parameter in the Setup menu.

FUNC=FULL

IN1, IN1L, IN1H are set according to input 1 signal

IN2, IN2L, IN2H are set according to input 2 signal

IN1U, DP1, IN2U, DP2, are set according to input 1 and input 2 signal

PVMD=P1-2 or P2-1

SPMD=SP1.2

The response of PV2 will be parallel to PV1 as shown in the following diagram

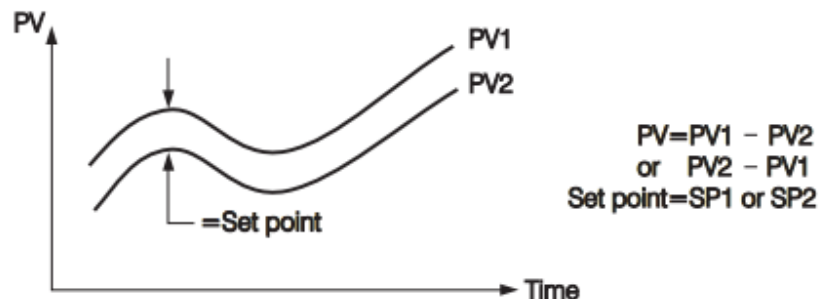

Figure 4-51. Relationship Between PV1 & PV2 for Differential Control

The PV display will indicate PV1-PV2 value if P1-2 is chosen for PVMD or PV2-PV1 value if P2-1 is chosen for PVMD. If the user needs PV1 or PV2 to be displayed instead of PV, they can use the Display Mode to select PV1 or PV2 to be viewed

If PVMD selects P1-2 or P2-1, while SPMD selects PV1 or PV2, an Error Code will appear. In this case the signals used for input 1 and input 2 should be the same unit and same decimal point, that is, IN1U=IN2U, DP1=DP2, otherwise Error Code will appear.

4.3.1.1.4.21 Output Power Limit

In certain system the heater (or cooler) is over-designed such that the process is too heavily heated or cooled. To avoid an excessive overshoot and/or undershoot the user can use the Power Limit function. Output 1 power limit PL1 is contained in Configuration. If output 2 is not used for cooling (that is COOL is not selected for OUT2), then PL2 is hidden. If the controller is used for ON-OFF control, then both PL1 and PL2 are hidden

Example:

OUT2=COOL, PB1=10.0°C, CPB=50, PL1=50, PL2=80 the output 1 and output 2 will act as following curves

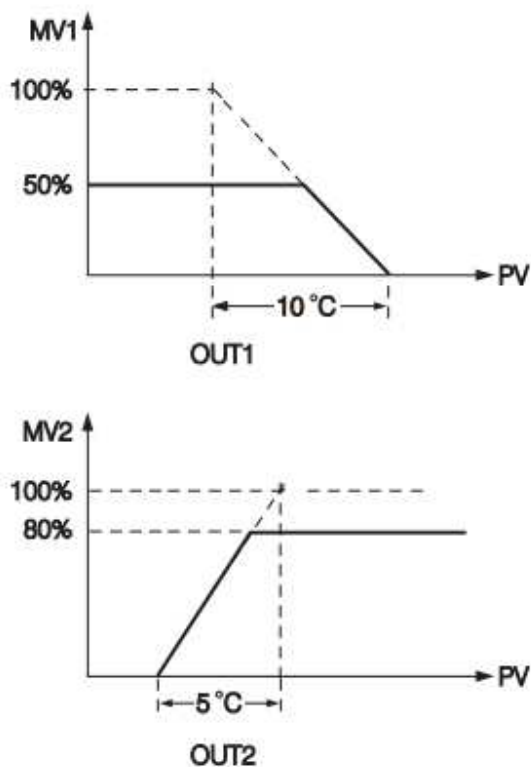

Figure 4-52. Power Limit Function

NOTE:

The adjusting ranges of MV1 (H) and MV2 (C) for manual control and/or failure transfer are not limited by PL1 and PL2.

4.3.1.1.4.22 Digital Filter

In certain application the process value is too unstable to be read. To improve this programmable low pass filter incorporated in this Process Control Card can be used. This is a first order filter with time constant specified by FILT parameter which is contained in setup menu. The default value of FILT is 0.5 sec. before shipping. Adjust FILT to change the time constant

from 0 to 60 seconds. 0 second represents no filter is applied to the input signal. The filter is characterized by the following diagram.

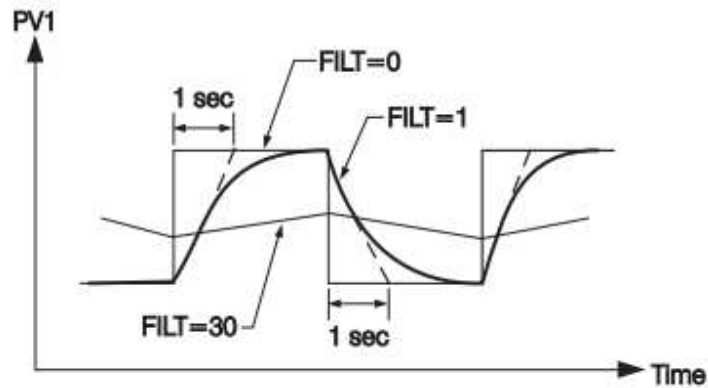



Figure 4-53. Filter Characteristics

Note:

The Filter is available only for PV1, and is performed for the displayed value only. The controller is designed to use unfiltered signal for control even if Filter is applied. A lagged (filtered) signal, if used for control, may produce an unstable process.

4.3.1.1.4.23 Auto-Tuning and Manual Tuning

The Auto-tuning and Manual tuning can be executed by pressing the mode button in the

Process control module realtime display page. Press  and Press Real Time and Press C1 to access the Process Control module real time display page.

Press Mode and select Auto-tuning to perform auto tuning for the process. During Auto-tuning process the PV display will blink continuously.

Press Mode and select Manual tuning to perform manual tuning for the process. In this the user can control the process manually by adjusting the output value manually.

Press Back to exit auto tuning or manual tuning when it is in progress.

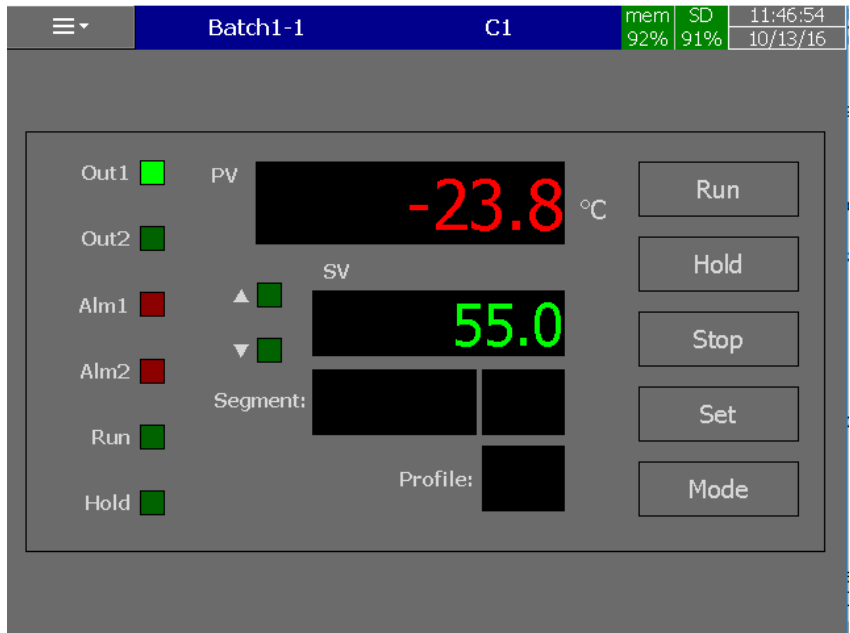

Figure 4-54.Process Control Module Real time

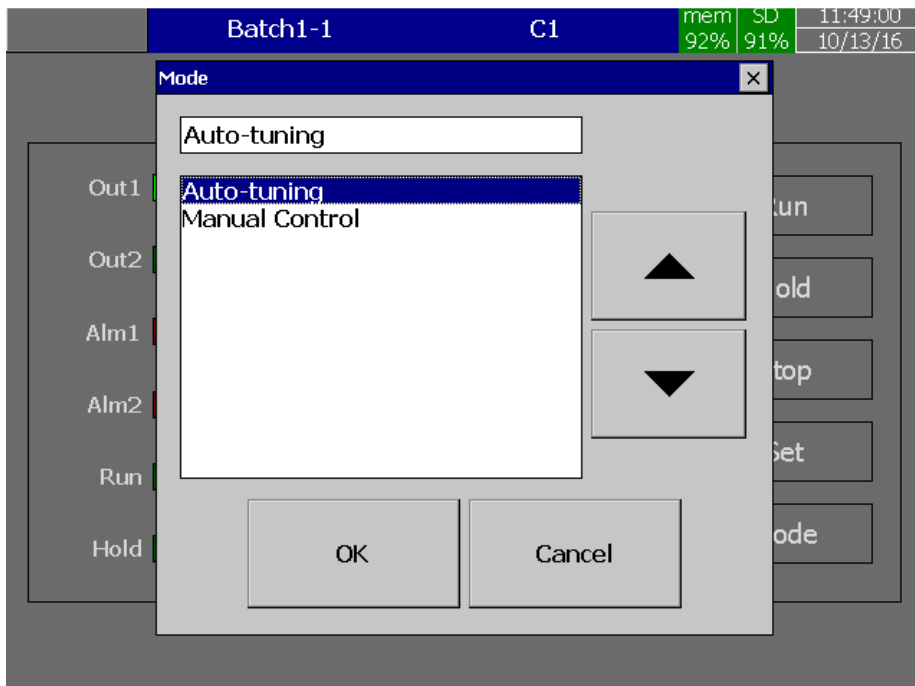

Figure 4-55.Auto-Tuning

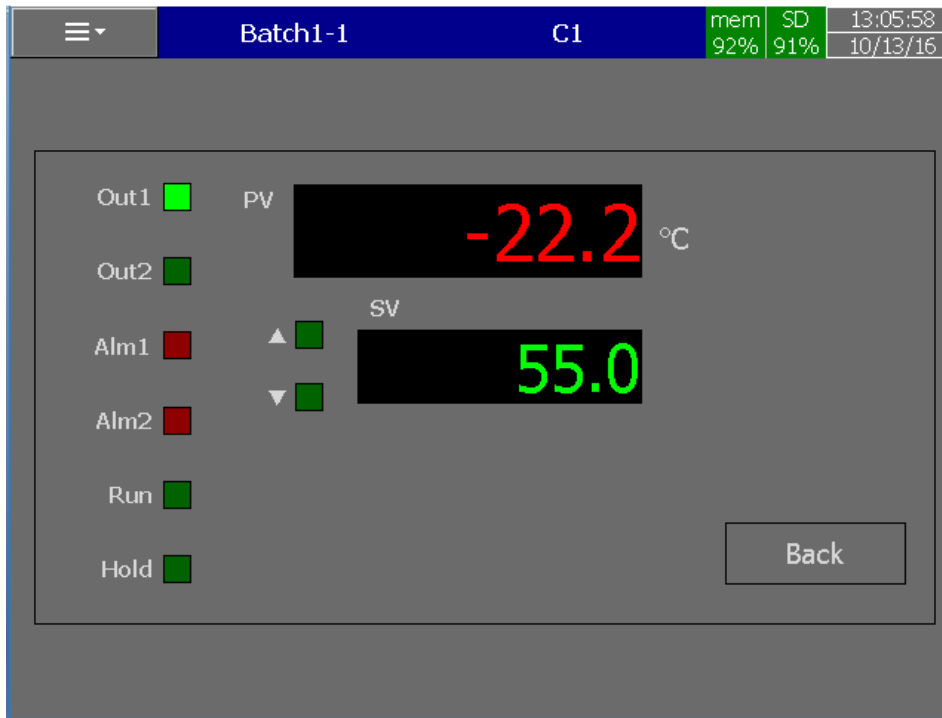

Figure 4-56.Auto-Tuning In progress

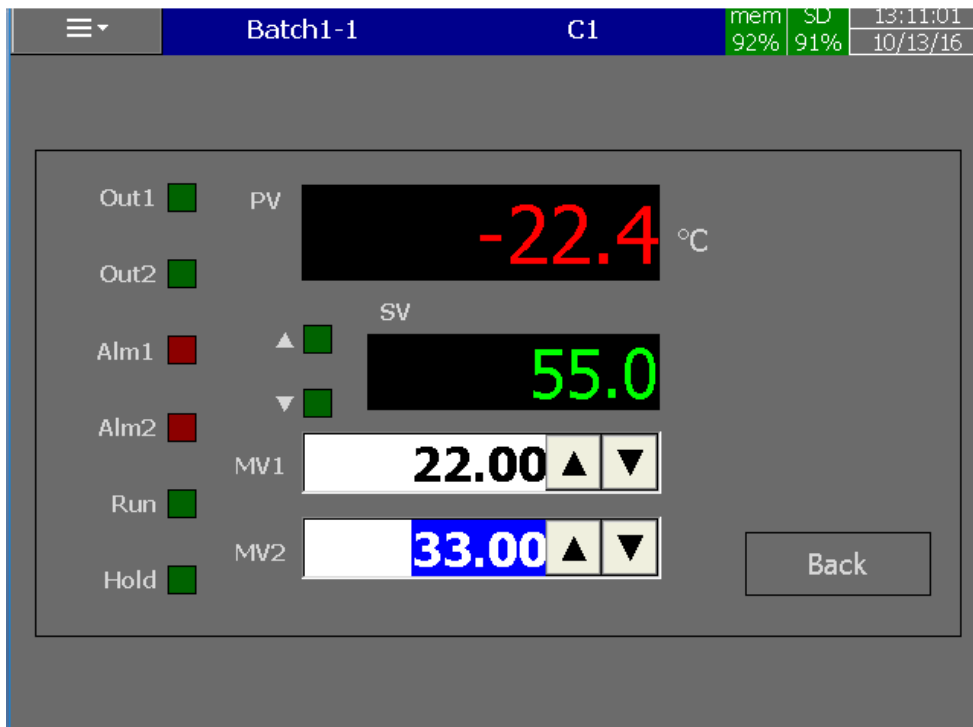





Figure 4-57.Manual Tuning In Progress

4.3.1.2 Ramp & Dwell(Profile)

Press Profile and press **Enter Key** to Entering in to the Process Control Card Ramp & Dwell configuration. Initially it displays **Profile1** for configuration. Use the navigational keys to Use

the navigational keys to select the next Profile .Use the   key move to other Profiles.

Use   key to move between the different Profile Configuration Parameters. There are 50 Profiles are available with 32 segments for configuration which is limited to total of 1000 segments.

After completing the configuration press **Back** button and then press  to return to main display and save the configuration automatically.

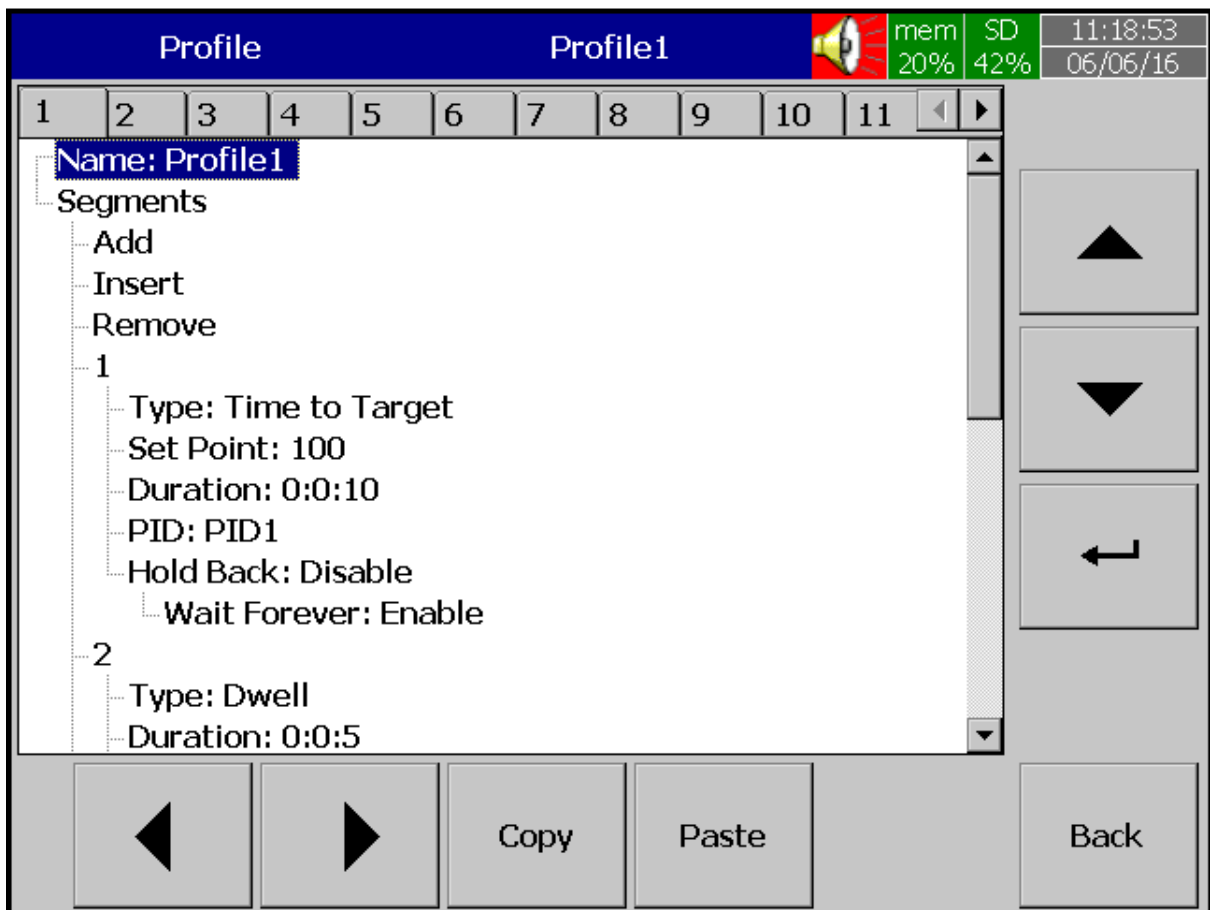

Figure 4-58.Ramp & Dwell Configuration Window

Name:

Enable the user to define the name for each Profile with the maximum limit of 18 Characters. Select "Name", then Press "Enter", soft key, a keyboard with several keys appears. Press "Shift" to select special characters. Press "Caps" to select capital letters. Press soft key "OK" after entering a new Profile name.

4.3.1.2.1 Ramp & Dwell:

Many applications need to vary temperature or process value with time. Such applications need a controller which varies a set point as a function of time. This Process Control Process Control Card can do this. The set point is varied by using a set point profiler. The profile is stored as a series of "ramp" and "dwell" segments, as shown below.

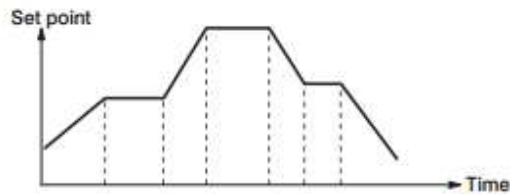

Figure 4-59. Set Point Profile

In each segment you can define the state of up to 3 event outputs which can drive either relay, logic or triac outputs, depending on the modules installed. A profile is executed either once, repeated a set number of times or repeated continuously. If repeated a set number of times, then the number of cycles must be specified as part of the profile.

The below are the available types of segment

Ramp:

Ramp to a new set point at a set rate or in a set time

Time to Target:

Ramp to a segment with a Set point in a set time.

Dwell:

Dwell for a set time

Go Back:

Jump to a specified segment in the same profile

End:

Make this segment the end of the profile

The below four kinds of combination are allowable for connecting segments.

- ❖ Ramp-Ramp
- ❖ Ramp-Dwell
- ❖ Dwell-Ramp
- ❖ Dwell-Dwell

4.3.1.2.2 Segments:

The user can **add** or **Insert** or **Remove** the segments of the Profile in this section. Press Add and then press Enter Soft key to access the Segment Configuration window.

Type:

Select the Segment type. The Available segment types are as below.

- ❖ Ramp
- ❖ Time To Target
- ❖ Dwell
- ❖ Go Back
- ❖ End

4.3.1.2.2.1 Ramp Segment Parameters:

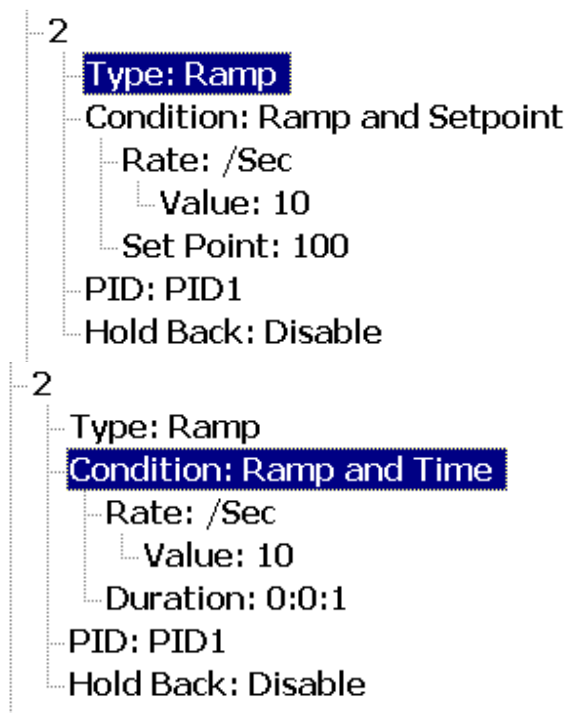

Figure 4-60.Ramp Segment

Condition:

The condition to be selected for Ramp Segment to follow to reach set point as **Ramp and Set point** or **Ramp and Time**. The **Ramp and SetPoint** will change the set point to reach the Set point in that segment in the Ramp Rate specified. The **Ramp and Time** will change the Set point based on the ramp rate specified for the duration mentioned.

Rate:

Ramp Rate of the segment to reach the set point .The **Ramp Rate** unit can be set for /Sec./Min./Hour. The **Ramp Rate Value** can be defined in value.

Duration:

Duration of the segment for the Ramp can be set in Hour: Minute: Second.

PID:

The PID Values to be used for this RAMP is PID1 or PID2.

Hold Back:

As the set point ramps up or down (or dwells), the measured value may lag behind or deviate from the set point by an undesirable amount. "Holdback" is available to freeze

the profile at its current state. The action of Holdback is the same as a deviation alarm. It can be enabled or disabled. Holdback has three parameters.

- ❖ Holdback wait time
- ❖ Holdback band
- ❖ Holdback type.

If the error from the set point exceeds the set holdback band (Band), then if the holdback feature is enabled it will automatically freeze the profile at its current point. At the same time, the holdback timer begins to count. When the value of holdback timer exceeds the value of holdback wait time (wait time), the profiler will no longer be freeze and jump to its next segment, at the same time an error code HBER will be displayed. If the error comes within the holdback band (Band), then the program will resume normal running.

Hold Back Types:

There are four different Holdback types. The choice of type is made by setting Holdback parameter when creating a profile with any one of the following

- ❖ **OFF**-Disables Holdback - no action is taken.
- ❖ **Deviation Lo**-Deviation Low Holdback holds the profile back when the process value deviates below the set point by more than the holdback band (Band).
- ❖ **Deviation High**-Deviation high holdback holds the profile back when the process value deviates above the set point by more than the holdback band (Band).
- ❖ **Deviation Lo/High** -Deviation Lo/High Holdback is a combination of the two. It holds the profile back when the process value deviates either above or below the set point by more than the holdback band (Band).

Hold Back Action:

Holdback action is defined by the below parameters.

- ❖ Wait Forever
- ❖ Wait Time

If **wait forever is enabled** then process will wait until the PV is come within Holdback band (Band). If **wait forever is disabled** then the holdback action specified in **Action after a timeout** will be finished after the time specified in **wait time**. The available holdback actions are **Hold** and **Continue**. Hold will hold the segment and the continue will move to the next segment.

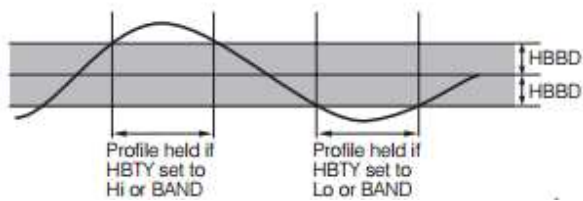

Figure 4-61. Hold Back on Dwell

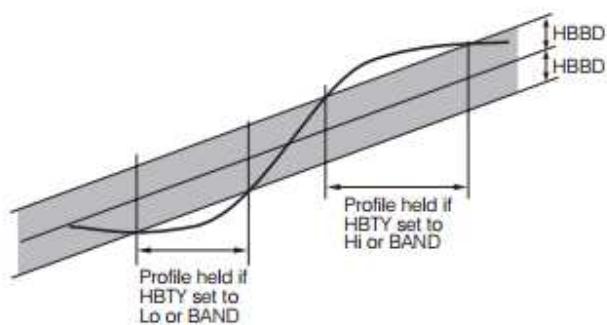

Figure 4-62. Hold Back on Positive Ramp

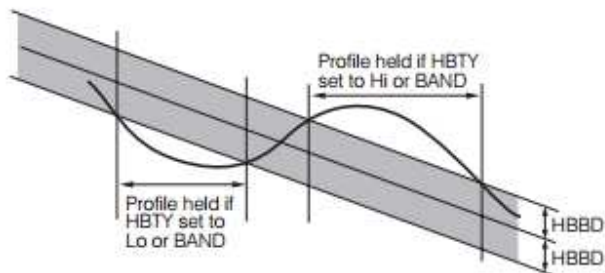

Figure 4-63. Hold Back Negative Ramp

4.3.1.2.2.2 Dwell Segment Parameters:

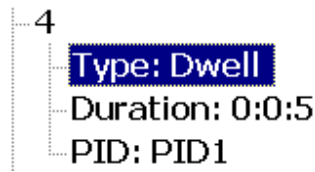

Figure 4-64.Dwell Segment

Duration:

Duration of the segment for the Dwell can be set in Hour: Minute: Second.

PID:

The PID Values to be used for this Dwell is PID1 or PID2.

4.3.1.2.2.3 Go Back Segment Parameters:

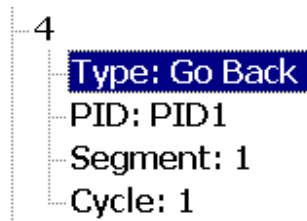

Figure 4-65.Go Back Segment

This segment will jump to the specified in the segment mentioned on the **Segment** for the no of cycles mentioned in **Cycle**.

4.3.1.2.2.4 End Segment Parameters:

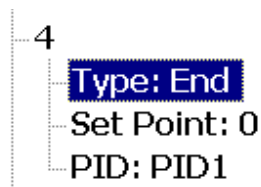

Figure 4-66.End Segment

This is an End segment of the profile to End the profile with set point mentioned in Set Point with the PID values in the selection of PID1 or PID2 as per the selection.

4.3.1.2.2.5 Time to Target Segment Parameters:

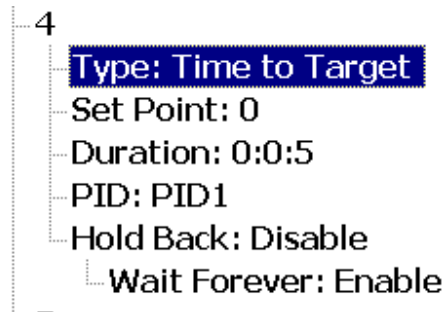

Figure 4-67. Time To Target Segment

This is similar to ramp segment with automatic calculation of ramp rate by the Process Control Card with the reference of Set point and duration given by the user.

Set Point:

Set Point to be reached in this segment. Of the segment

Duration:

Duration of the segment to reach the set point

PID:

The PID Values to be used for this RAMP is PID1 or PID2.

Holdback:

Hold back actions to be enable or not. Refer the details in Ramp segment section for detailed explanation.

4.3.1.2.3 Start/End Jobs

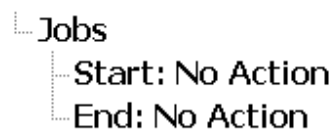

Figure 4-68. Profile Start/End Job

Start: Define the job to be done at the start of the Profile(Ramp &Dwell)

End: Define the job to be done at the End of the Profile(Ramp &Dwell)

The details of the jobs available in the Recorder user manual.

4.3.1.2.4 Start/Stop Profile(Ramp &Dwell)

The Profile can be start ,Hold or stop from the Real time display page of process control module.The Profile can be selected and run from the Run button on the display page.Press **Run** and select the profile to be run then press ok to start the Profile.

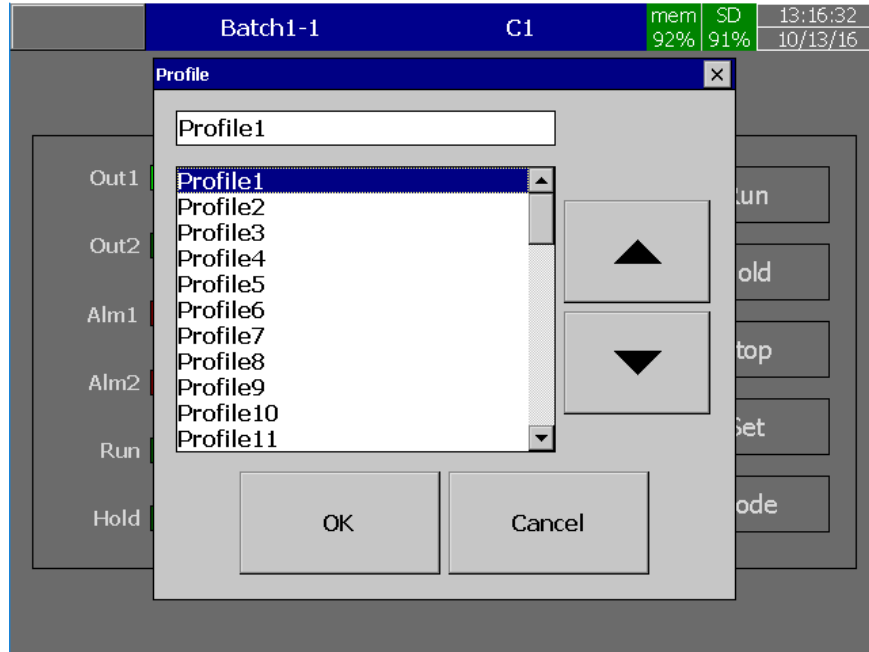

Figure 4-69.Run Profile

Press **Hold** to holde the profile. Press **Stop** to stop the Profile.

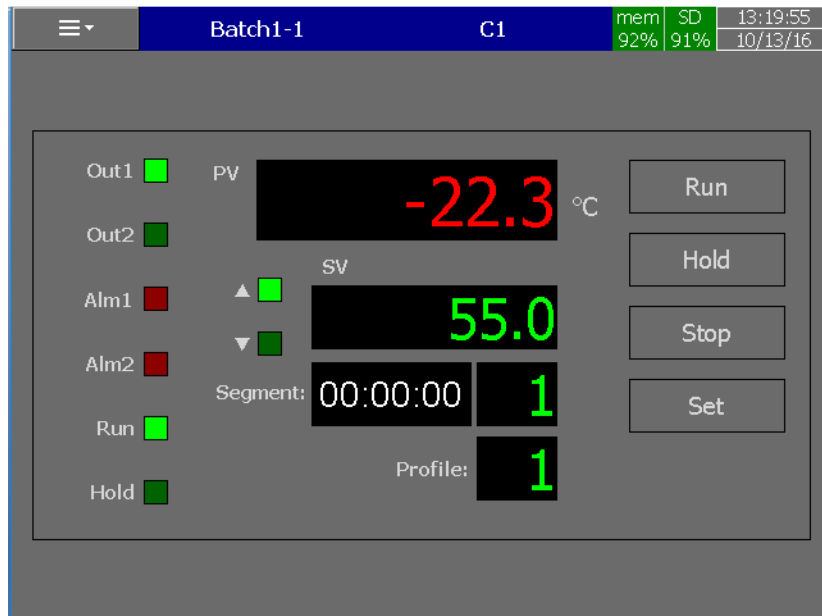

Figure 4-70.Profile Running

The real time display page will show the Profile and Segment no along with the remaining time of that particular segment.

4.4 Display

The Display menu allows the user to configure PV and SV in to display. Each Process Control Card have two parameters can be added to display page as per the user requirement. Refer Recorder user manual for the detailed explanation.

5 Application

5.1 Oven Control with Zone Temperature Recording

An Oven is designed to dry the products with 6 zones. The Zone Temperature is controlled by a single temperature controller. The temperature of the different zones are recorded to ensure the operation of different zones. Generally for this application one temperature controller and 6 channel recorder are required. By using PR Series Recorder with PID Control card it can be achieved with one device.

The oven required to dry the products at 500°C for 1 hour. All the 6 zones temperature needs to be recorded. For this dwell timer of PID Control card needs to be used for control the oven temperature and Analog inputs of Recorder needs to be connected with Thermocouple inputs from all the zones. The system configuration is as below.

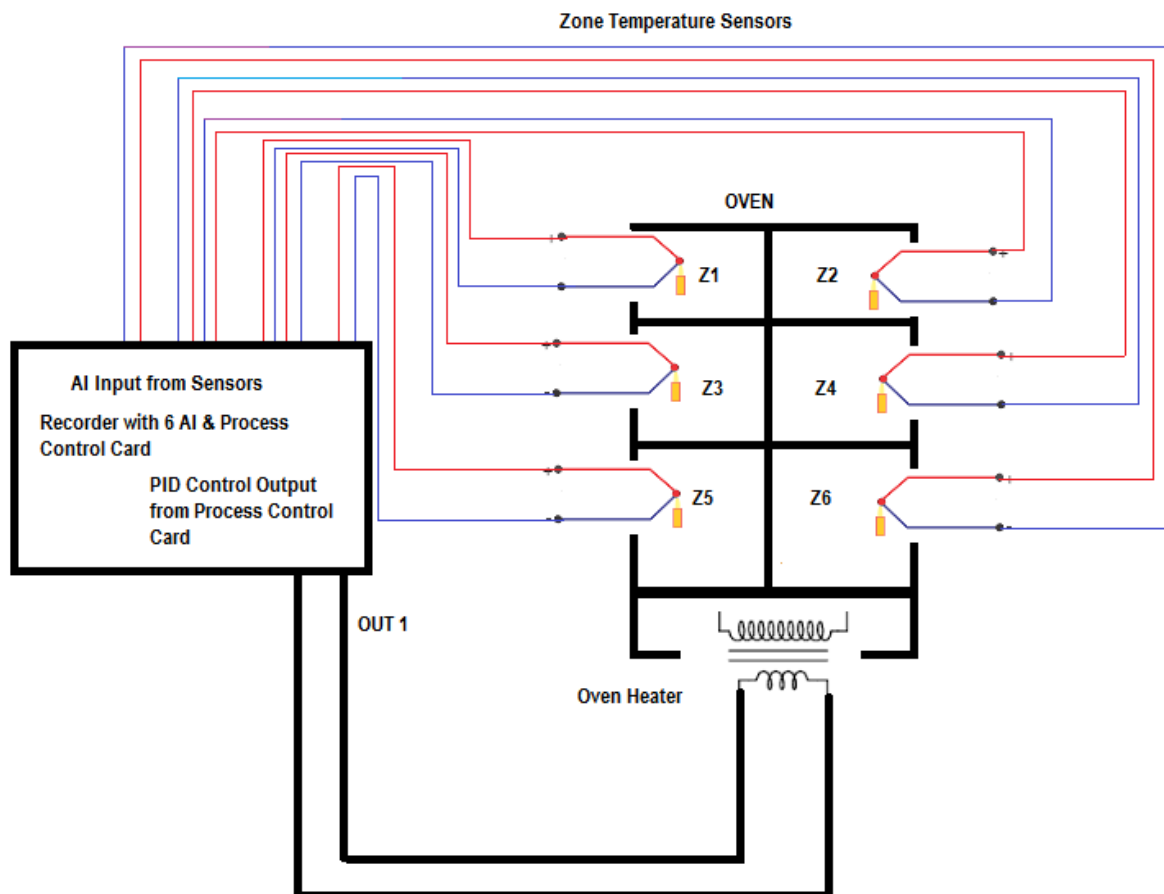

Figure 5-1. Oven Control with Zone Temperature Recording

To achieve this function set the following parameters in the PID Control setup menu and configure the Recorder as per the recording requirements.

FUNC=BASC (Basic function)

IN1=K_TC

IN1U= C

DP1=1_DP

OUT1=REVR

O1TY=RELY

CYC1=18.0

O1FT=BPLS

A1FN=TIMR

A1FT=ON

SELF=NONE

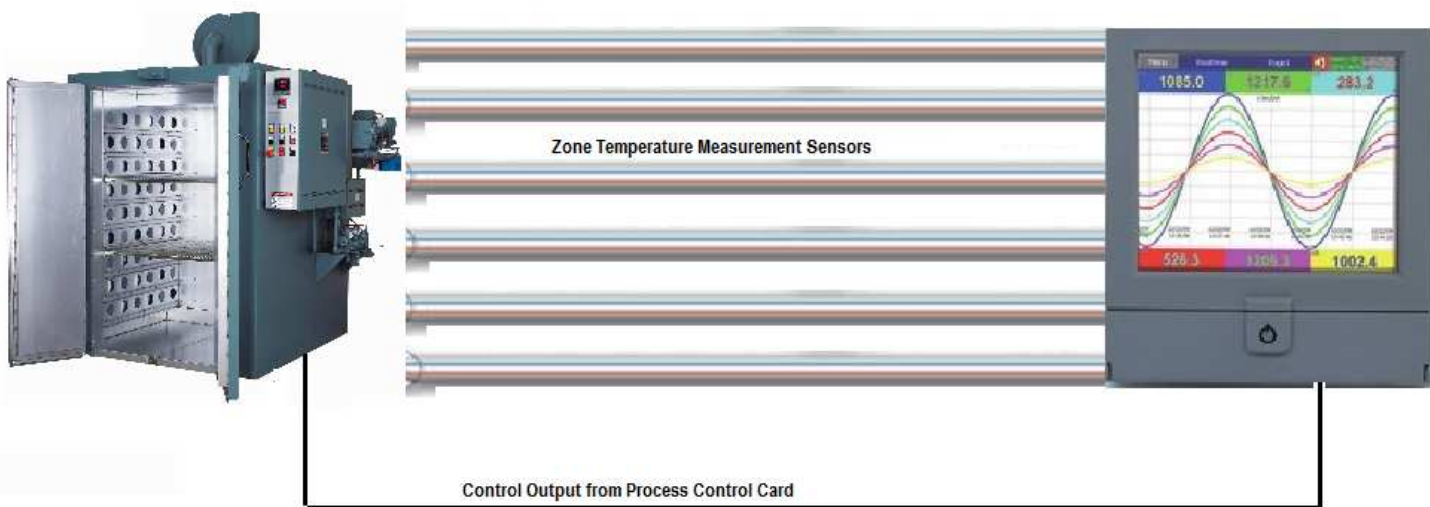

Figure 5-2. Oven Control with Zone Temperature Recording System