



# CLASSIC Series | TCM 230K Coriolis Mass Flow Meter

## FEATURES

- Robust, no moving parts for long life
- Custom flow connectors & installation lengths
- Excellent repeatability ( $\pm 0.05$  % of flow rate)
- Optional Net Oil functionality

## BENEFITS

- ▶ Increased productivity, less maintenance
- ▶ Lower installation cost
- ▶ Increased product quality
- ▶ Simpler whole solution for Net Oil without PLC/RTU

## FLOW RATE

Mass Flow Rate (max.):	230,000 kg/h [8,450 lb/min]
Volumetric Flow Rate (max.):	230,000 l/h [1,013 gpm, 34,720 oil bbl/d (US)]
Nominal Meter Size:	DN80 [3"]

**PRESSURE RATING** 100 bar [1,450 psi]

## ACCURACY (LIQUIDS)<sup>1)</sup>

Basic Accuracy (Mass Flow) <sup>2)</sup> :	$\pm 0.3$ % (option: up to $\pm 0.15$ % of flow rate)
Repeatability (Mass Flow):	$\pm 0.05$ % of flow rate
Basic Accuracy (Volume Flow) <sup>2)</sup> :	$\pm 0.3$ % (option: up to $\pm 0.2$ % of flow rate)
Repeatability (Volume Flow):	$\pm 0.05$ % of flow rate
Zero Stability:	$\pm 0.015$ % of full scale

## ACCURACY (GASES)

Basic Accuracy (Mass Flow) <sup>2)</sup> :	$\pm 1$ % (option: up to $\pm 0.5$ % of flow rate)
Repeatability (Mass Flow):	$\pm 0.25$ % of flow rate

## DENSITY

Density Range:	up to 2,500 kg/m <sup>3</sup> [2.5 g/cm <sup>3</sup> ]
Density Accuracy <sup>2)</sup> :	$\pm 1.0$ kg/m <sup>3</sup> [ $\pm 0.001$ g/cm <sup>3</sup> ]
Density Repeatability:	$\pm 0.5$ kg/m <sup>3</sup> [ $\pm 0.0005$ g/cm <sup>3</sup> ]

## TEMPERATURE

Process Temperature Range:	-40 °C ... +100 °C [-40 °F ... +212 °F] Option: -60 °C ... +200 °C [-76 °F ... +392 °F]
Temperature Accuracy:	$\pm 1$ °C $\pm 0.5$ % of reading [ $\pm 1.8$ °F $\pm 0.5$ % of reading]
Temperature Repeatability:	$\pm 0.2$ °C [ $\pm 0.36$ °F]

## MATERIALS (WETTED PARTS)

Tubes:	1.4404 [AISI 316L]
Case:	1.4404 [AISI 316L]
Flow Splitter:	CF3M [1.4409]
Option:	NACE MR 0175/0103 compliant

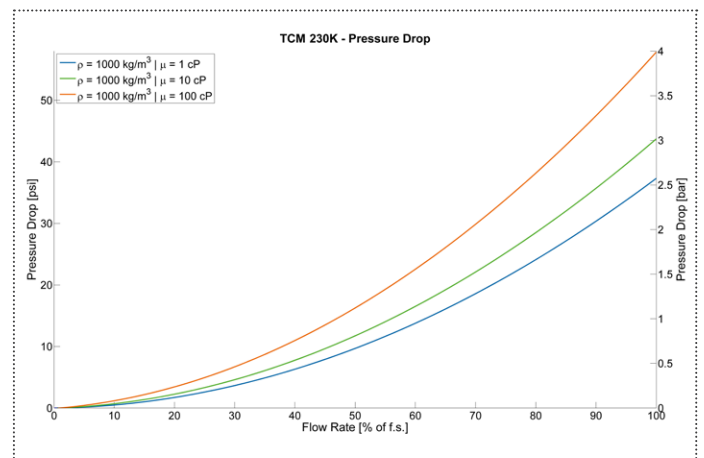

<sup>1)</sup> Stated flow accuracy combines the effects of repeatability, linearity and hysteresis.  
<sup>2)</sup> The specifications refer to standard conditions (for further information see TCM CLASSIC series manual).



# CLASSIC Series | TCM 230K Coriolis Mass Flow Meter

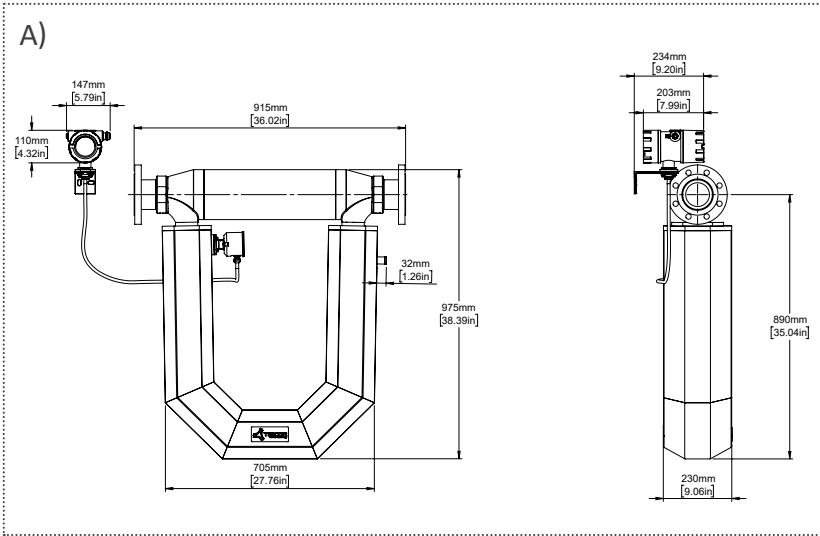

## METER DIMENSIONS<sup>3)</sup> AND WEIGHTS

### A) Remote Version

Weight: 87 kg [191.8 lb]

With junction box and remote field mount

### Standard Process Connection

DN80 PN40 [3" ANSI CL 300] (others on request)

## EX-CERTIFICATIONS

ATEX	Zone 1:
	Group IIC or IIB, T2...T4
IECEX	Zone 1:
	Group IIC or IIB, T2...T4
cCSAus <sup>5)</sup>	Class 1, Division 1:
	Group A, B, C, D or C, D, T2...T4
ATEX + IECEx + cCSAus triple approval <sup>6) 7)</sup>	Zone 1:
	Group IIC or IIB, T2...T4
	Class 1, Division 1:
EAC (TR-CU) <sup>6)</sup>	Group A, B, C, D or C, D, T2...T4
	Group IIC or IIB, T2 ... T4

## PANEL MOUNT<sup>4)</sup>



## REMOTE MOUNT<sup>5)</sup>

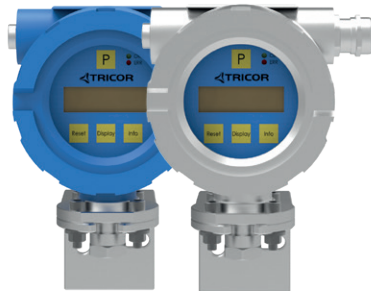

## ELECTRONICS

Power Supply:	24 V DC $\pm 20\%$ or 90 ... 264 V AC
Outputs:	Analog, Frequency, Pulse, Status
Interfaces:	RS485 RTU (Modbus), HART <sup>®</sup>
Cable Gland:	M20   1/2" NPT

<sup>3)</sup> Drawing of the Meter Dimensions reflects one standard connection, other connections on request (Installation length can vary depending on selected connection).

<sup>4)</sup> Weight: 0.4 kg [0.88 lb].

<sup>5)</sup> Weight with aluminum diecast housing: 3.8 kg [8.4 lb] with 3 m cable, Weight with 1.4404 [AISI 316L] housing: 6.15 kg [13.56 lb].

<sup>6)</sup> For Ex1, Ex3, EAC (TR-CU) the electronic is only available in aluminum housing.

<sup>7)</sup> Only with remote electronics.

[www.tricorflow.com](http://www.tricorflow.com)

**N & S AMERICA**  
 AW-Lake Company  
 2440 W. Corporate Preserve Dr. #600  
 Oak Creek WI 53154 | USA  
 +1 414 574 4300

**ASIA PACIFIC & MIDDLE EAST**  
 KEM Küppers Elektromechanik GmbH  
 1 Magazine Road #04-01  
 Central Mall Office Tower  
 Singapore 059567  
 +65 6347 6162

**CHINA**  
 KEM flow technology (Beijing) Co., Ltd.  
 Rm. 906, Block C, RuiPu Office Bldg, No. 15  
 HongJunYingNan Road  
 Chaoyang District, Beijing 100012 | China  
 +86 10 84929567



**REST OF WORLD**  
 KEM Küppers Elektromechanik GmbH  
 Liebigstraße 5  
 85757 Karlsfeld | Germany  
 +49 8131 59391-100