

VUE-3215

21.5" Touch Monitor

Preliminary



Features

- 21.5" active screen size
- 6-axis color adjustment (Green/Red/Blue/Cyan/Magenta/Yellow) for high level and more accuracy customized image
- Full-flat cover glass for extremely simple and elegant surface design
- Anti-glare (AG) treatment on screen for comfortable viewing experience
- Front IK08 high-level impact protection
- Adopts industrial-grade components for guaranteed performance
- Support 10-point touch function (PCAP technology)
- Excellent touch noise immunity well-suited for rugged applications (CS 10V)
- Compliant with many touch methods including fingers, glove, and stylus
- Built-in multiple I/O interfaces for diverse media connectivity

Specifications

Display	Active Screen Size		21.5 inch
	Resolution		1920 x 1080 (FHD)
	Brightness		250nits (Typ.)
	Contrast Ratio		3000:1
	Aspect Ratio		16:9 (Wide)
	Viewing Angle		89° / 89° / 89° / 89° (Typ)
Touch	Backlight Life (hours)		40,000 (Typ.)
	Touch Type		Projected Capacitive Touch (PCAP)
	Touch Function		10 points
	Touch Interface		USB
	Touch Method		Finger/Glove
	Stylus		Active Pen (optional accessory)
Connectivity	Input	Video	VGA x 1, HDMI x 1, DVI-D x 1, DisplayPort x 1
		Audio	Audio line in x 1
		Control	USB typeB x 1 (for touch function)
		Others	USB3.0 x 2
	Output	Video	N/A
		Audio	2W+2W Internal Speaker
Control		N/A	
System	OS		N/A
	OSD Language		English, Spanish, French, Portuguese, Russian, Simplified Chinese, Traditional Chinese, Korean
	OSD Function		TBD
Power	Power Type		External Adapter, AC to DC, 19V
	Power Input-AC		100-240V _{ac} , 50-60Hz, 1.5A
	Power Consumption		TBD
Environment	Operating	Temperature	0°C ~ 40°C
		Humidity	10% to 85% (non-condensing)
	Storage	Temperature	-20 ~ 60 °C
		Humidity	5% to 80% (non-condensing)
Mechanical Specification	Housing Material		Texture (Black/White)
	Waterproof Rating		N/A
	VESA Compatibility		100 x 100 mm
	Side mount screw hole		N/A
	Hand Hoder/Stand		Yes, with hinge stand
	Cable Management		N/A
	Dimensions (W x H x D)	Physical with stand	512.5 x 318.4 x 63.5 mm
		Packing	609 x 415 x 201 mm
	Weight	Net	7.8 kg
Gross		9 kg	
Installation	Installation rotation		Landscape
	Mounting on a wall		100 x 100 mm, VESA grid
	Mounting with stand/arm		100 x 100 mm, VESA grid
	Mounting through bracket		N/A
	Extending PC/peripherals		N/A
Certificate		CB, UL, BSMI, CCC, CE, UKCA, FCC, CEC, ErP lot5	
Warranty		2 years	

Dimensions

Unit: mm

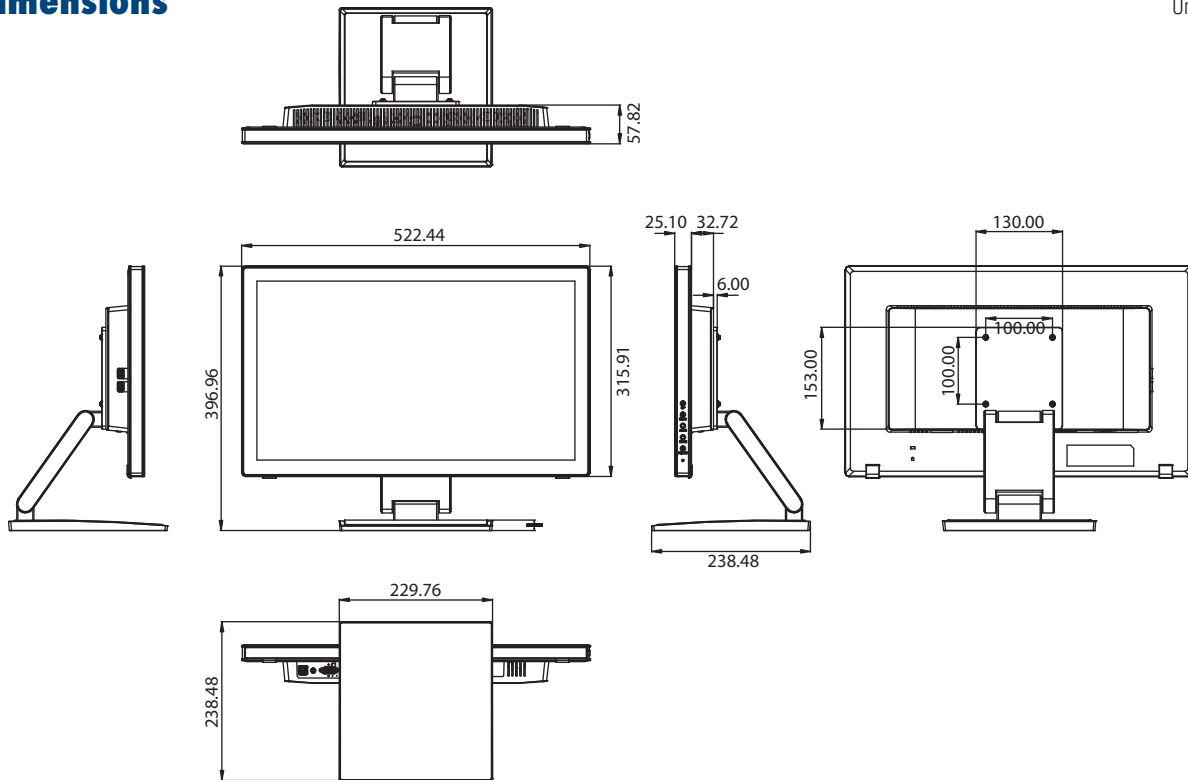

Ordering Information

Part Number		Description	Packing List
Black housing	White housing		
VUE-3215-FD25PA-N4	VUE-3215-FD25PA-N3	Advantech 21.5" Full HD PCAP Touch Monitor (incl. Japan, Korea, Australia, and Middle East Power Cord)	<ul style="list-style-type: none"> ▪ Power Cord (1.5M, Black) ▪ Power Adaptor (1.5M, Black) ▪ VGA Cable (1.5M, Black) ▪ HDMI Cable (1.5M, Black) ▪ DisplayPort Cable (1.5M, Black) ▪ DVI Cable (1.5M, Black) ▪ USB Cable (1.8M, Black) ▪ Audio Cable (1.5M, Black) ▪ Hinge Stand (Black/White housing) ▪ Startup Manual (Paper)
VUE-3215-FD25PC-N4	VUE-3215-FD25PC-N3	Advantech 21.5" Full HD PCAP Touch Monitor (incl. China Power Cord)	
VUE-3215-FD25PX-N4	VUE-3215-FD25PX-N3	Advantech 21.5" Full HD PCAP Touch Monitor (incl. Europe, Taiwan, UK and US Power Cord)	

Optional Accessories

Part Number	Description
96OT-A15DEE-B0	Active Stylus Pen for VUE-2000 and VUE-3000 series, Black