

SIDE MOUNTING

Liquid Float Level Switches

DESCRIPTION

Magnetrol® side mounting controls mount horizontally to any tank or vessel through a threaded or flanged pipe connection. Standard models are normally equipped with a single switch mechanism for high or low level alarm or control applications. Tandem models, with two switch mechanisms, are available for two-stage applications.

FEATURES

- Body material of carbon steel or stainless steel
- 300 series stainless steel float and trim
- Threaded or flanged mounting
- Specific gravity ratings down to 0.40
- Process temperatures to +540 °C (+1000° F)
- Field-adjustable level differential
- Choice of switch mechanism:
Dry contact, Hermetically sealed, Pneumatic
- Choice of switch mechanism enclosure:
Weatherproof, Explosion proof, Intrinsically safe

Optional:

- NACE construction
- Interface calibration
- Special actuating levels
- Code compliance construction
- Special tank connections
- Extreme temperature modifications
- Special exterior surface preparation and finish

APPLICATIONS

- Day Tanks
- Condensate Receivers
- Fuel Storage Tanks
- Cooling Towers
- Flash Tanks
- Interface
- High and high/high alarm from single tank entry

Up to 409 mm (16.12") switch differential

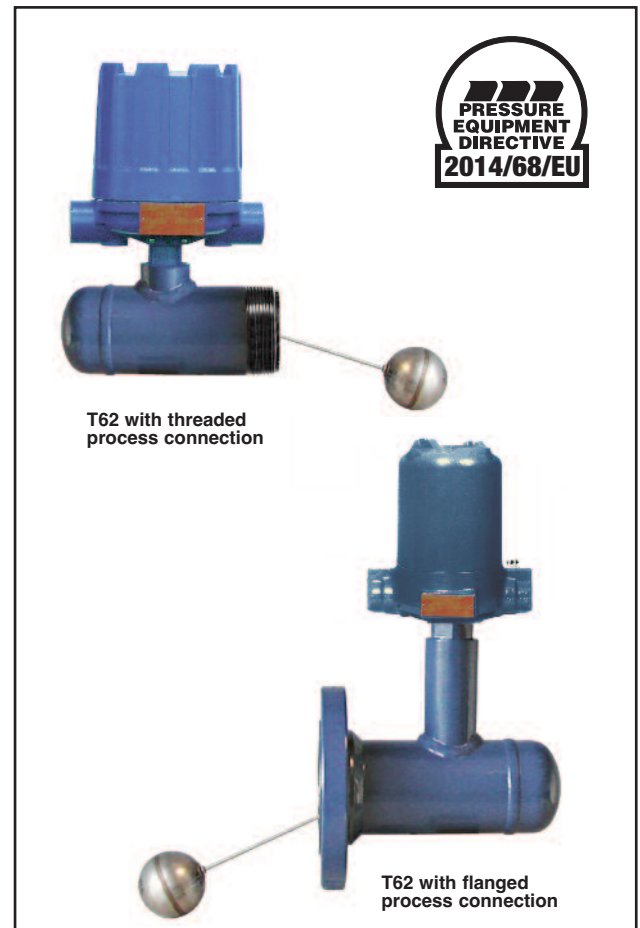

PRINCIPLE OF OPERATION



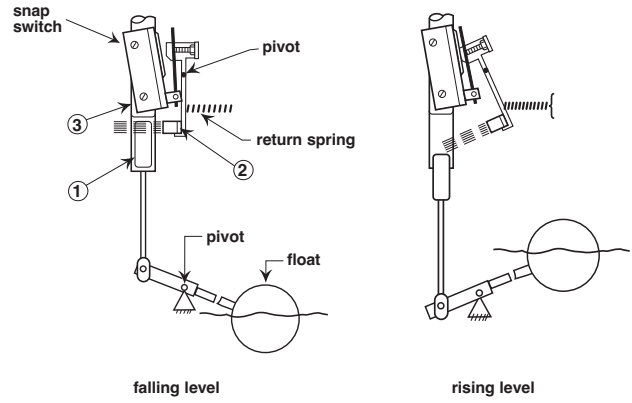

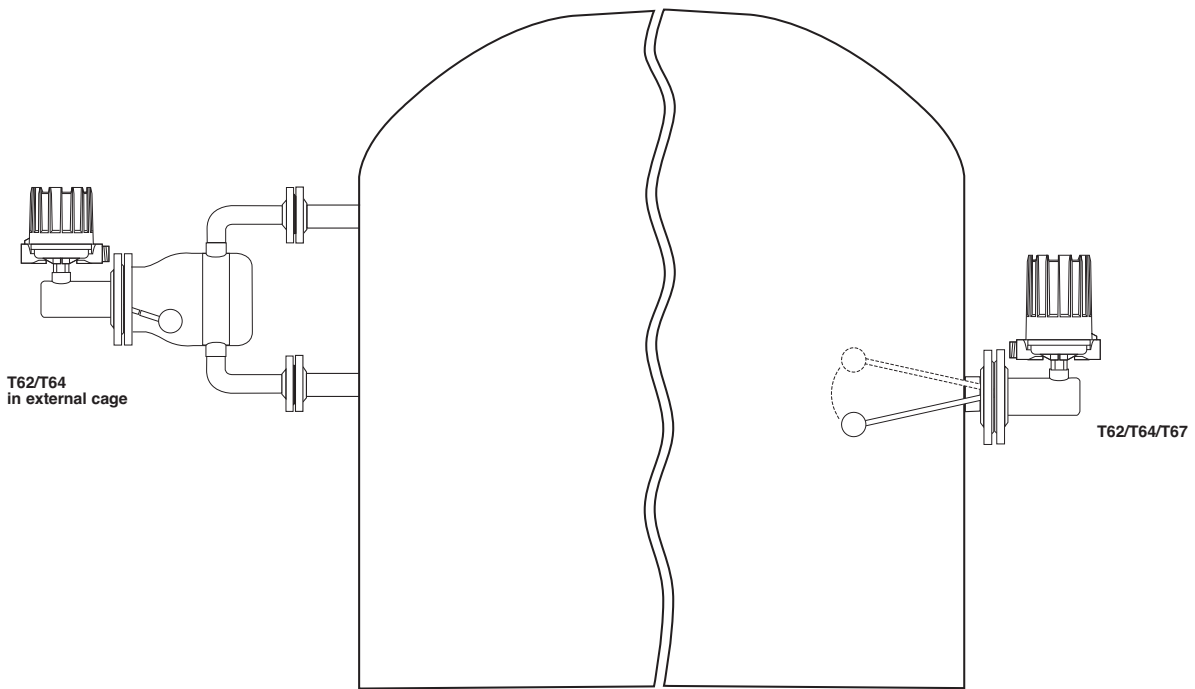

Side mounting units employ permanent magnetic force as the only link between the float and the switching element. As the pivoted float follows liquid level changes, it moves a magnetic sleeve ① into or out of the field of a switch actuating magnet ② causing switch operation. A non-magnetic barrier tube ③ effectively isolates the switch mechanism from the controlled liquid.



MOUNTING



AGENCY APPROVALS

AGENCY	APPROVED MODEL	AREA CLASSIFICATION
ATEX 	All with electric switch mechanism and housing listed as ATEX Ex d	ATEX II 2 G Ex d IIC T6 Gb
	All with electric switch mechanism and housing listed as ATEX Ex ia	ATEX II 1 G Ex ia IIC T6 Ga
FM 	All with electric switch mechanism and housing listed as NEMA 7/9	Class I, Div 1, groups C & D Class II, Div 1, Groups E, F & G
	Consult factory for proper model numbers	Class I, Div 1, groups B, C & D Class II, Div 1, Groups E, F & G
IECEX 	All with electric switch mechanism and housing listed as IECEX Ex d	Ex d IIC T6
	All with electric switch mechanism and housing listed as IECEX Ex ia	Ex ia IIC T6 Ga
CSA 	Consult factory for proper model numbers	Class I, Div 1, groups C & D Class II, Div 1, Groups E, F & G
	Consult factory for proper model numbers	Class I, Div 1, groups B, C & D Class II, Div 1, Groups E, F & G
EAC (Russia, Kazakhstan, Belarus) 	All with electric switch mechanism and housing listed as ATEX Ex d	1Ex d IIC T6 Gb
	All with electric switch mechanism and housing listed as ATEX Ex ia	0Ex ia IIC T4 Ga
CE 	The units are conform to the ATEX directive 2014/34/EU, PED directive 2014/68/EU, Low Voltage Directive 2014/35/EU and RoHS directive 2011/65/EU	
Other approvals are available, consult factory for more details		

SWITCH MECHANISMS AND HOUSINGS

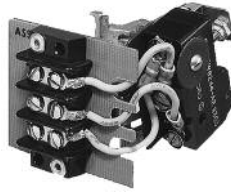

Series B, C, D, R & U Dry contact switches ^①

- Series B and C switches are general purpose units with a selection of maximum liquid temperature ratings
- Series D switch is designed for high DC current applications
- Series U switches have gold alloy contacts
- Series R switches are designed for the highest temperature applications up to +540 °C (+1000 °F)



Series J & K Pneumatic switches ^③

- Suited for process industry applications in hazardous locations or where electrical power is not available
- Series J bleed type switch is intended for general purpose applications
- Series K switch is specially designed to provide non-bleed operation with a high degree of vibration resistance



Series HS ^②, F, W, X, 8 & 9 Hermetically sealed switches

- Entire mechanism and contacts are contained within a positively pressurized capsule with series HS
- Ideal for use in salt and other corrosive atmospheres



Switch housings ^①

- Die cast aluminium housings
- Cast iron housings
- Stainless steel housings
- Optional housing heaters and drains available for some housings
- Pneumatic switch mechanisms available with alu base/cold rolled steel cover
- Electrical switch mechanisms for high temperature available with aluminium base / cold rolled steel cover



Series V Inductive Proximity switch ^④

- Series V switches are inductive proximity switches type SJ3,5-SN with a maximum liquid temperature rating of +100 °C (+210 °F)

Basic electrical ratings ^①

Voltage	Switch Series and Non-Inductive Ampere Rating										
	B	C	D	F	HS	R	U	W	X	8	9
120 V AC	15.00	15.00	10.00	2.50	5.00	1.00	1.00	1.00	0.50	1.00	1.00
240 V AC	15.00	15.00	—	—	5.00	1.00	—	1.00	0.50	—	—
24 V DC	6.00	6.00	10.00	4.00	5.00	1.00	1.00	3.00	0.50	3.00	1.00
120 V DC	0.50	1.00	10.00	0.30	0.50	0.40	—	0.50	0.50	—	—
240 V DC	0.25	0.50	3.00	—	0.25	—	—	—	—	—	—

^① For more details see bulletin BE 42-683

^② For more details on HS Hermetically sealed switches, see bulletin BE 42-694

^③ For more details on J & K Pneumatic switches, see bulletin BE 42-685 and bulletin BE 42-686

^④ For more details on V Inductive Proximity switches, see bulletin BE 42-798

SELECTION DATA

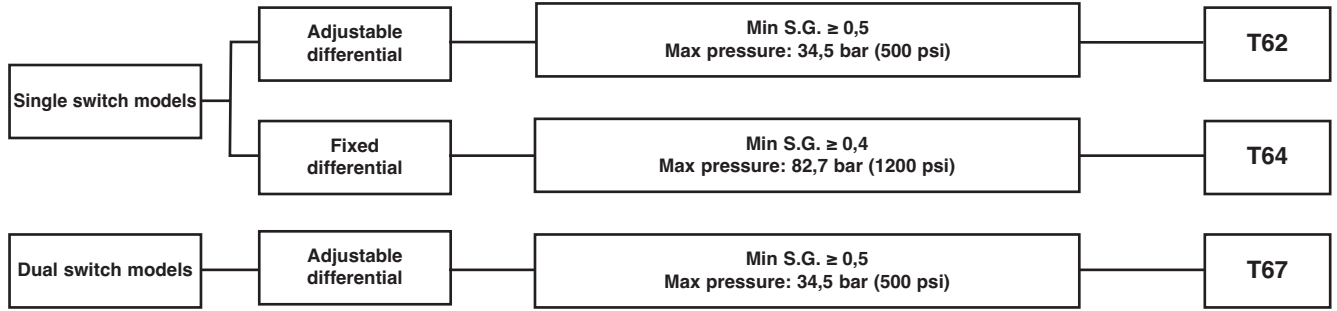

Level differential in mm (inches)

Models	dim. "D"	Differential	dim. "L" ^①	Float stem length versus level differential			
				203 mm (8")	305 mm (12")	457 mm (18")	660 mm (26")
T62 threaded	77,9 mm (3.07") 3" – Sch 40	min	Not applicable	32 (1.26)	51 (2.01)	73 (2.87)	102 (4.02)
		max	50 mm (2")	148 (5.83)	206 (8.11)	294 (11.58)	409 (16.10)
			100 mm (4")	111 (4.37)	155 (6.10)	221 (8.70)	310 (12.20)
			150 mm (6")	38 (1.50)	119 (4.69)	170 (6.69)	236 (9.29)
			200 mm (8")	-	97 (3.82)	138 (5.43)	192 (7.56)
			250 mm (10")	-	81 (3.19)	116 (4.57)	162 (6.38)
305 mm (12")	-	-	100 (3.94)	138 (5.43)			
T62 flanged	73,7 mm (2.90") 3" – Sch 80	min	Not applicable	32 (1.26)	41 (1.61)	67 (2.64)	95 (3.74)
		max	50 mm (2")	89 (3.50)	130 (5.12)	191 (7.52)	273 (10.75)
			100 mm (4")	83 (3.27)	121 (4.76)	178 (7.01)	254 (10.00)
			150 mm (6")	-	95 (3.74)	137 (5.39)	197 (7.76)
			200 mm (8")	-	76 (2.99)	114 (4.49)	159 (6.26)
			250 mm (10")	-	64 (2.52)	95 (3.74)	137 (5.39)
305 mm (12")	-	-	83 (3.27)	117 (4.61)			
T64 flanged	102,3 mm (4.03") 4" – Sch 40	fixed	max 178 mm (7")	32 (1.26)	Not applicable	Not applicable	Not applicable
T67 threaded	77,9 mm (3.07") 3" – Sch 40	min	max 57 mm (2.25")	25 (1.00)	38 (1.50)	54 (2.12)	76 (3.00)
		max		64 (2.50)	95 (3.75)	140 (5.50)	197 (7.75)
T67 flanged	73,7 mm (2.90") 3" – Sch 80	min	max 89 mm (3.50")	25 (1.00)	38 (1.50)	54 (2.12)	76 (3.00)
		max		48 (1.88)	68 (2.69)	99 (3.88)	140 (5.50)

All units are factory set at minimum differential unless otherwise specified. Consult factory for differentials not shown.

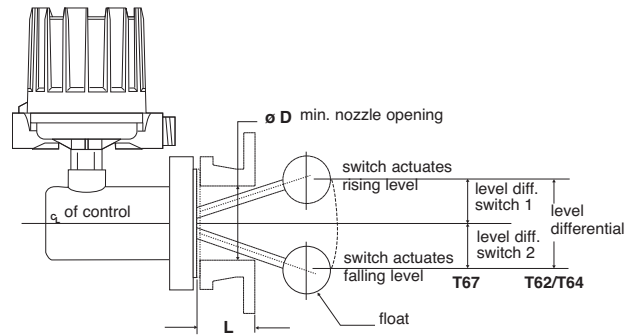
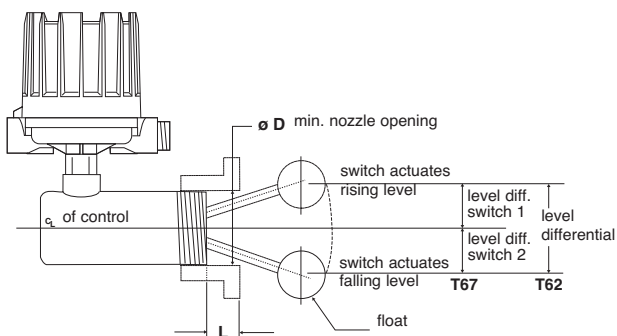

① Nozzle length is dimension L from end of standard control body to opening in tank having minimum diameter listed for each model.

SELECTION DATA T62/T64 SINGLE SWITCH

A complete measuring system consists of:

Order code for **T62** models:

MODEL NUMBER CODE AND MATERIALS OF CONSTRUCTION

Model No.	Set points	Cage & process connection	Float and trim	Magnetic sleeve
T62-A	1	Carbon steel	316 SST (1.4401)	400 series SST
T62-B				316 SST (1.4401)
T62-D		316/316L SST (1.4401/1.4404)		

PROCESS CONNECTION

– threaded

F 2	3" NPT
-----	--------

– ASME flanges

G 3	3" 150 lbs ASME RF
G 4	3" 300 lbs ASME RF
H 3	4" 150 lbs ASME RF
H 4	4" 300 lbs ASME RF

– EN flanges

7 F	DN 80, PN 16	EN 1092-1 Type B1
7 G	DN 80, PN 25/40	EN 1092-1 Type B1
8 F	DN 100, PN 16	EN 1092-1 Type B1
8 G	DN 100, PN 25/40	EN 1092-1 Type B1

FLOAT AND STEM LENGTH

Stem length versus min S.G.								Float size mm (inches) ^①	Max pressure bar (psi)	
203 mm (8")		305 mm (12")		457 mm (18")		660 mm (26")			@ 40 °C (100 °F)	@ 540 °C (1000 °F)
A	0,80	B	0,80	C	0,90	D	0,90	ø 64 (2.50)	24,1 (350)	18,5 (268)
E	0,52	F	0,55	G	0,60	H	0,66	ø 64 x 102 (2.50 x 4.00)	6,9 (100)	5,3 (77)
J	0,55	K	0,55	L	0,60	M	0,60	ø 76 (3.00)	17,2 (250)	13,2 (191)
N	0,50	P	0,50	Q	0,55	R	0,55	ø 89 (3.50)	27,6 (400)	21,1 (306)
S	0,65	T	0,65	V	0,70	W	0,70	ø 76 x 127 (3.00 x 5.00)	34,5 (500)	23,1 (335)

^① All floats can be screwed to float stem from inside of vessel in case the float cannot pass through the nozzle.

SWITCH MECHANISM & HOUSING (next page)

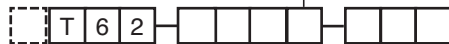

complete order code for T62 models

X = product with a specific customer requirement

Order code for **T64** models:

MODEL NUMBER CODE AND MATERIALS OF CONSTRUCTION

Model No.	Set points	Cage & process connection	Float and trim	Magnetic sleeve
T64-A	1	Carbon steel	304 SST (1.4301) / 316 SST (1.4401)	400 series SST
T64-B				316 SST (1.4401)

PROCESS CONNECTION

– ASME flanges

H 3	4" 150 lbs ASME RF
H 4	4" 300 lbs ASME RF
H 5	4" 600 lbs ASME RF

– EN flanges

8 F	DN 100, PN 16	EN 1092-1 Type B1
8 G	DN 100, PN 25/40	EN 1092-1 Type B1
8 H	DN 100, PN 63	EN 1092-1 Type B2
8 J	DN 100, PN 100	EN 1092-1 Type B2

FLOAT AND STEM LENGTH

N	Fixed stem length: 203 mm (8") Min. S.G: 0,40 Float size: ø 89 mm (3.50") Float rating: 82,7 bar (1200 psi) @ 40 °C (100 °F) 54,7 bar (794 psi) @ 540 °C (1000 °F)
---	--

SWITCH MECHANISM & HOUSING (next page)

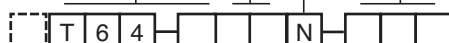

complete order code for T64 models

X = product with a specific customer requirement

SELECT ELECTRIC SWITCH MECHANISM & HOUSING

Switch Description	Process ① Temperature Range °C (°F)	Contacts	T62-A & T64-A Models									T62-B, T62-D & T64-B Models								
			Weather proof (IP 66)		ATEX - IECEx (IP 66)						FM (IP 66) NEMA 7/9	Weather proof (IP 66)		ATEX - IECEx (IP 66)						FM (IP 66) NEMA 7/9
					II 2G Ex d IIC T6 Gb			II 1G Ex ia IIC T6 Ga						II 2G Ex d IIC T6 Gb			II 1G Ex ia IIC T6 Ga			
			Cast Aluminium		Cast Aluminium		Cast Iron (ATEX only)		Cast Aluminium		Cast Alu.	Cast Aluminium		Cast Aluminium		Cast Iron (ATEX only)		Cast Aluminium		Cast Alu.
M20x1,5	1" NPT	M20x1,5	1" NPT	M20x1,5	3/4" NPT	M20x1,5	1" NPT	1" NPT	M20x1,5	1" NPT	M20x1,5	1" NPT	M20x1,5	1" NPT	M20x1,5	3/4" NPT	M20x1,5	1" NPT		
Series B Snap switch	-40 to +120 (-40 to +250)	1x SPDT	B2P	BAP	BHC	BAC	BK7	BU7	-	-	BKP	B2Q	BAQ	BH9	BA9	BK5	BU5	-	-	BKQ
		1x DPDT	B8P	BDP	BJC	BBC	BD7	BW7	-	-	BNP	B8Q	BDQ	BJ9	BB9	BD5	BW5	-	-	BNQ
Series C Snap switch	-40 to +230 (-40 to +450)	1x SPDT	C2P	CAP	CHC	CAC	CK7	CU7	C2L	CAL	CKP	C2Q	CAQ	CH9	CA9	CK5	CU5	C2S	CAS	CKQ
		1x DPDT	C8P	CDP	CJC	CBC	CD7	CW7	C8L	CDL	CNP	C8Q	CDQ	CJ9	CB9	CD5	CW5	C8S	CDS	CNQ
Series D DC Current Snap switch	-40 to +120 (-40 to +250)	1x SPDT	-	-	-	-	-	-	-	-	-	D2Q	DAQ	DH9	DA9	DK5	DU5	-	-	DKQ
		1x DPDT	-	-	-	-	-	-	-	-	-	D8Q	DDQ	DJ9	DB9	DD5	DW5	-	-	DNQ
Series F Hermetically sealed Snap switch	-45 to +400 (-50 to +750)	1x SPDT	F2P	FAP	FHC	FAC	FK7	FU7	-	-	FKP	F2Q	FAQ	FH9	FA9	FK5	FU5	-	-	FKQ
		1x DPDT	F8P	FDP	FJC	FBC	FD7	FW7	-	-	FNP	F8Q	FDQ	FJ9	FB9	FD5	FW5	-	-	FNQ
Series HS Hermetically sealed Snap switch	-45 to +290 ② (-50 to +550)	1x SPDT	-	-	-	-	-	-	-	-	-	H7A	HM2	HFC	HA9	HB3	HB4	-	-	HM3
		1x DPDT	-	-	-	-	-	-	-	-	-	H7C	HM6	HGC	HB9	HB7	HB8	-	-	HM7
Series U Gold alloy contacts Snap switch	-40 to +120 (-40 to +250)	1x SPDT	U2P	UAP	UHC	UAC	UK7	UU7	U2L	UAL	UKP	U2Q	UAQ	UH9	UA9	UK5	UU5	U2S	UAS	UKQ
		1x DPDT	U8P	UDP	UJC	UBC	UD7	UW7	U8L	UDL	UNP	U8Q	UDQ	UJ9	UB9	UD5	UW5	U8S	UDS	UNQ
Series V Inductive Proximity switch	-40 to +100 (-40 to +210)	-	-	-	-	-	-	VFS	VHS	-	-	-	-	-	-	-	-	V5S	VBS	-
Series W Hermetically sealed Silver plated contacts Snap switch	-45 to +230 (-50 to +450)	1x SPDT	W2P	WAP	WHC	WAC	WK7	WU7	W2L	WAL	WKP	W2Q	WAQ	WH9	WA9	WK5	WU5	W2S	WAS	WKQ
		1x DPDT	-	-	-	-	-	-	-	-	-	W8Q	WDQ	WJ9	WB9	WD5	WW5	W8S	WDS	WNQ
Series X Hermetically sealed Gold plated contacts Snap switch	-45 to +230 (-50 to +450)	1x SPDT	X2P	XAP	XHC	XAC	XK7	XU7	X2L	XAL	XKP	X2Q	XAQ	XH9	XA9	XK5	XU5	X2S	XAS	XKQ
		1x DPDT	-	-	-	-	-	-	-	-	-	X8Q	XDQ	XJ9	XB9	XD5	XW5	X8S	XDS	XNQ
Series R High temperature Snap switch	-40 to +400 (-40 to +750)	1x SPDT	-	-	-	-	-	-	-	-	-	R2Q	R1Q	RH9	RA9	RK5	RU5	-	-	RKQ
		1x DPDT	-	-	-	-	-	-	-	-	-	R8Q	RDQ	RJ9	RB9	RN5	RF5	-	-	RNQ
Series 8 Hermetically sealed Snap switch	-45 to +400 (-50 to +750)	1x SPDT	82P	8AP	8HC	8AC	8K7	8U7	-	-	8KP	82Q	8AQ	8H9	8A9	8K5	8U5	-	-	8KQ
		1x DPDT	88P	8DP	8JC	8BC	8D7	8W7	-	-	8NP	88Q	8DQ	8J9	8B9	8D5	8W5	-	-	8NQ
Series 9 High temperature Hermetically sealed Snap switch	-45 to +400 (-50 to +750)	1x SPDT	92P	9AP	9HC	9AC	9K7	9U7	-	-	9KP	92Q	9AQ	9H9	9A9	9K5	9U5	-	-	9KQ
		1x DPDT	98P	9DP	9JC	9BC	9D7	9W7	-	-	9NP	98Q	9DQ	9J9	9B9	9D5	9W5	-	-	9NQ
Switch Description	Process ① Temperature Range °C (°F)	Contacts	Weather proof (IP 65)		ATEX (IP 66)				Weather proof (IP 65)		ATEX (IP 66)									
					II 2G Ex d IIC T6 Gb						II 2G Ex d IIC T6 Gb									
			CS/Aluminium		Cast Iron				CS/Aluminium		Cast Iron									
			3/4" NPT		M20x1,5		3/4" NPT		3/4" NPT		M20x1,5		3/4" NPT							
Series R High temperature Snap switch	-40 to +540 ③ (-40 to +1000)	1x SPDT	-	-	-	-	-	-	-	R1Y	-	RK5	-	RU5						
		1x DPDT	-	-	-	-	-	-	-	RDY	-	RN5	-	RF5						
Series 9 High temperature Hermetically sealed Snap switch	-40 to +540 ③ (-40 to +1000)	1x SPDT	9AR	-	9K7	-	9U7	-	-	9AY	-	9K5	-	9U5						
		1x DPDT	9DR	-	9D7	-	9W7	-	-	9DY	-	9D5	-	9W5						

SELECT PNEUMATIC SWITCH MECHANISM & HOUSING

Switch Description	Max supply pressure bar (psi)	Max liquid temperature ① °C (°F)	Bleed orifice Ø mm (inches)	NEMA 3R (IP 53)	
				T62-A & T64-A Models	T62-B, T62-D & T64-B Models
Series J (open air)	6,9 (100)	200 (400)	1,60 (0.063)	JDG	JDE
	4,1 (60)		2,39 (0.094)	JEG	JEE
	4,1 (60)	370 (700)	1,40 (0.055)	JFG	JFE
Series K (closed circuit)	6,9 (100)	200 (400)	-	-	KOE
	2,8 (40)		-	KOG	-

① Process temperature based on max. 40 °C (100 °F) ambient temperature and for non steam applications.
 ② On steam applications, temperature down-rated to +200 °C (+400 °F) process at +40 °C (+100 °F) ambient.
 ③ Upon prolonged exposure to temperatures above 425 °C (800 °F), the carbide phase of steel may be converted to graphite. Permissible but not recommended for prolonged use above 425 °C (800 °F). (Applies to models T62-A & T62-B, T64-A & T64-B.)

SELECTION DATA T67 DUAL SWITCH

A complete measuring system consists of:

Order code for **T67** models:

MODEL NUMBER CODE AND MATERIALS OF CONSTRUCTION

Model No.	Set points	Cage & process connection	Float and trim	Magnetic sleeve
T67-A	2	Carbon steel	316 SST (1.4401)	400 series SST
T67-B				316 SST (1.4401)
T67-D		316/316L SST (1.4401/1.4404)		

PROCESS CONNECTION

– threaded

F	2	3" NPT
---	---	--------

– ASME flanges

G	3	3" 150 lbs ASME RF
G	4	3" 300 lbs ASME RF
H	3	4" 150 lbs ASME RF
H	4	4" 300 lbs ASME RF

– EN flanges

7	F	DN 80, PN 16	EN 1092-1 Type B1
7	G	DN 80, PN 25/40	EN 1092-1 Type B1
8	F	DN 100, PN 16	EN 1092-1 Type B1
8	G	DN 100, PN 25/40	EN 1092-1 Type B1

FLOAT AND STEM LENGTH

Stem length versus min S.G.								Float size mm (inches) ^①	Max pressure bar (psi)	
203 mm (8")		305 mm (12")		457 mm (18")		660 mm (26")			@ 40 °C (100 °F)	@ 540 °C (1000 °F)
A	0,80	B	0,80	C	0,90	D	0,90	ø 64 (2.50)	24,1 (350)	18,5 (268)
E	0,52	F	0,55	G	0,60	H	0,66	ø 64 x 102 (2.50 x 4.00)	6,9 (100)	5,3 (77)
J	0,55	K	0,55	L	0,60	M	0,60	ø 76 (3.00)	17,2 (250)	13,2 (191)
N	0,50	P	0,50	Q	0,55	R	0,55	ø 89 (3.50)	27,6 (400)	21,1 (306)
S	0,65	T	0,65	V	0,70	W	0,70	ø 76 x 127 (3.00 x 5.00)	34,5 (500)	23,1 (335)

^① All floats can be screwed to float stem from inside of vessel in case the float cannot pass through the nozzle.

SWITCH MECHANISM & HOUSING (next page)

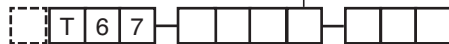

complete order code for T67 models

→ X = product with a specific customer requirement

SELECT ELECTRIC SWITCH MECHANISM & HOUSING

Switch Description	Process ^① Temperature Range °C (°F)	Contacts	T67-A Models									T67-B & T67-D Models								
			Weather proof (IP 66)		ATEX - IECEx (IP 66)						FM (IP 66)	Weather proof (IP 66)		ATEX - IECEx (IP 66)						FM (IP 66)
					II 2G Ex d IIC T6 Gb			II 1G Ex ia IIC T6 Ga						II 2G Ex d IIC T6 Gb			II 1G Ex ia IIC T6 Ga			
			Cast Aluminium		Cast Aluminium		Cast Iron (ATEX only)		Cast Aluminium		Cast Alu.	Cast Aluminium		Cast Aluminium		Cast Iron (ATEX only)		Cast Aluminium		Cast Alu.
M20x1,5	1" NPT	M20x1,5	1" NPT	M20x1,5	3/4" NPT	M20x1,5	1" NPT	1" NPT	M20x1,5	1" NPT	M20x1,5	1" NPT	M20x1,5	3/4" NPT	M20x1,5	1" NPT	1" NPT			
Series B Snap switch	-40 to +120 (-40 to +250)	2x SPDT	B4A	BBA	BLC	BDC	BL7	BV7	--	--	BLA	B4B	BBB	BL9	BD9	BL5	BV5	--	--	BLB
		2x DPDT	B1A	BEA	BPC	BGC	BO7	BY7	--	--	BOA	B1B	BEB	BP9	BG9	BO5	BY5	--	--	BOB
Series C Snap switch	-40 to +230 (-40 to +450)	2x SPDT	C4A	CBA	CLC	CLC	CL7	CV7	C4X	CBX	CLA	C4B	CBB	CL9	CD9	CL5	CV5	C4T	CBT	CLB
		2x DPDT	C1A	CEA	GPC	CGC	CO7	CY7	C1X	CEX	COA	C1B	CEB	CP9	CG9	CO5	CY5	C1T	CET	COB
Series D DC Current Snap switch	-40 to +120 (-40 to +250)	2x SPDT	--	--	--	--	--	--	--	--	D4B	DBB	DL9	DD9	DL5	DV5	--	--	DLB	
		2x DPDT	--	--	--	--	--	--	--	--	D1B	DEB	DP9	DG9	DO5	DY5	--	--	DOB	
Series F Hermetically sealed Snap switch	-45 to +400 (-50 to +750)	2x SPDT	FFA	FBA	FLC	FDC	FL7	FV7	--	--	FLA	FFB	FBB	FL9	FD9	FL5	FV5	--	--	FLB
		2x DPDT	FHA	FEA	FPC	FGC	FO7	FY7	--	--	FOA	FHB	FEB	FP9	FG9	FO5	FY5	--	--	FOB
Series U Gold alloy contacts Snap switch	-40 to +120 (-40 to +250)	2x SPDT	U4A	UBA	ULC	UDC	UL7	UV7	U4X	UBX	ULA	U4B	UBB	UL9	UD9	UL5	UV5	U4T	UBT	ULB
		2x DPDT	U1A	UEA	UPC	UGC	UO7	UY7	U1X	UEX	UOA	U1B	UEB	UP9	UG9	UO5	UY5	U1T	UET	UOB
Series W Hermetically sealed Silver plated contacts Snap switch	-45 to +230 (-50 to +450)	2x SPDT	W4A	WBA	WLC	WDC	WL7	WV7	W4X	WBX	WLA	W4B	WBB	WL9	WD9	WL5	WV5	W4T	WBT	WLB
		2x DPDT	W1B	WEB	WP9	WG9	WO5	WY5	W1T	WET	WOB	W1B	WEB	WP9	WG9	WO5	WY5	W1T	WET	WOB
Series X Hermetically sealed Gold plated contacts Snap switch	-45 to +230 (-50 to +450)	2x SPDT	X4A	XBA	XLC	XDC	XL7	XV7	X4X	XBX	XLA	X4B	XBB	XL9	XD9	XL5	XV5	X4T	XBT	XLB
		2x DPDT	X1B	XEB	XP9	XG9	XO5	XY5	X1T	XET	XOB	X1B	XEB	XP9	XG9	XO5	XY5	X1T	XET	XOB
Series R High temperature Snap switch	-40 to +400 (-40 to +750)	2x SPDT	R4B	R3B	RL9	RD9	RL5	RV5	--	--	RLB	R4B	R3B	RL9	RD9	RL5	RV5	--	--	RLB
		2x DPDT	RHB	REB	RP9	RG9	RO5	RG5	--	--	ROB	RHB	REB	RP9	RG9	RO5	RG5	--	--	ROB
Series 8 Hermetically sealed Snap switch	-45 to +400 (-50 to +750)	2x SPDT	84A	8BA	8LC	8DC	8L7	8V7	--	--	8LA	84B	8BB	8L9	8D9	8L5	8V5	--	--	8LB
		2x DPDT	81A	8EA	8PC	8GC	8O7	8Y7	--	--	8OA	81B	8EB	8P9	8G9	8O5	8Y5	--	--	8OB
Series 9 High temperature Hermetically sealed Snap switch	-45 to +400 (-50 to +750)	2x SPDT	94A	9BA	9LC	9DC	9L7	9V7	--	--	9LA	94B	9BB	9L9	9D9	9L5	9V5	--	--	9LB
		2x DPDT	91A	9EA	9PC	9GC	9O7	9Y7	--	--	9OA	91B	9EB	9P9	9G9	9O5	9Y5	--	--	9OB
Switch Description	Process ^① Temperature Range °C (°F)	Contacts	Weather proof (IP 65)	ATEX (IP 66)						Weather proof (IP 65)	ATEX (IP 66)									
				II 2G Ex d IIC T6 Gb							II 2G Ex d IIC T6 Gb									
			CS/Aluminium			Cast Iron			CS/Aluminium			Cast Iron								
			3/4" NPT			M20x1,5			3/4" NPT			3/4" NPT			M20x1,5					
Series R High temperature Snap switch	-40 to +540 ^② (-40 to +1000)	2x SPDT	R3M			RL5			RV5			R3M			RL5			RV5		
		2x DPDT	REM			RO5			RG5			REM			RO5			RG5		
Series 9 High temperature Hermetically sealed Snap switch	-40 to +540 ^② (-40 to +1000)	2x SPDT	9BD			9L7			9V7			9BM			9L5			9V5		
		2x DPDT	9ED			9O7			9Y7			9EM			9O5			9Y5		

① Process temperature based on max. 40 °C (100 °F) ambient temperature and for non steam applications.

② Upon prolonged exposure to temperatures above 425 °C (800 °F), the carbide phase of steel may be converted to graphite. Permissible but not recommended for prolonged use above 425 °C (800 °F). (Applies to models T67-A & T67-B.)

PHYSICAL SPECIFICATIONS

Description		Specification
Measured variable		Liquid level / interface level
Physical range		Standard models: min S.G. 0,40
Cage and process connection material		Carbon steel or stainless steel (others at request)
Wetted materials	Float	316 SST (1.4401) – T62/T67; 304 SST (1.4301) – T64
	Trim	316 SST (1.4401)
	Magnetic sleeve	316 SST (1.4401), or 400 series SST

FLOAT PRESSURE / TEMPERATURE RATINGS

Model	Float size mm (inches)	Max pressure bar (psi)			
		@ 40 °C (100 °F)	@ 400 °C (750 °F)	@ 480 °C (900 °F)	@ 540 °C (1000 °F)
T62/T67	ø 64 (2.50)	24,1 (350)	19,4 (282)	18,7 (271)	18,5 (268)
	ø 64 x102 (2.50 x 4.00)	6,9 (100)	5,6 (81)	5,4 (78)	5,3 (77)
	ø 76 (3.00)	17,2 (250)	13,9 (201)	13,4 (194)	13,2 (191)
	ø 89 (3.50)	27,6 (400)	22,2 (322)	21,4 (310)	21,1 (306)
	ø 76 x 127 (3.00 x 5.00)	34,5 (500)	26,0 (377)	24,3 (353)	23,1 (335)
T64	ø 89 (3.50)	82,7 (1200)	64,5 (936)	60,4 (876)	54,7 (794)

ELECTRICAL SPECIFICATIONS

Description	Specification
Switch ratings	Up to 15 A @ 240 V AC (depending on switch mechanism) Up to 10 A @ 120 V DC (depending on switch mechanism)
Signal output	Single or dual SPDT or DPDT contacts or single pneumatic
Switch types (see page 4)	Dry contact with standard or gold alloy contacts, Hermetically sealed, Hermetically sealed with gold or silver plated contacts, Proximity switch, or single pneumatic bleed and non bleed

ELECTRICAL CONNECTION

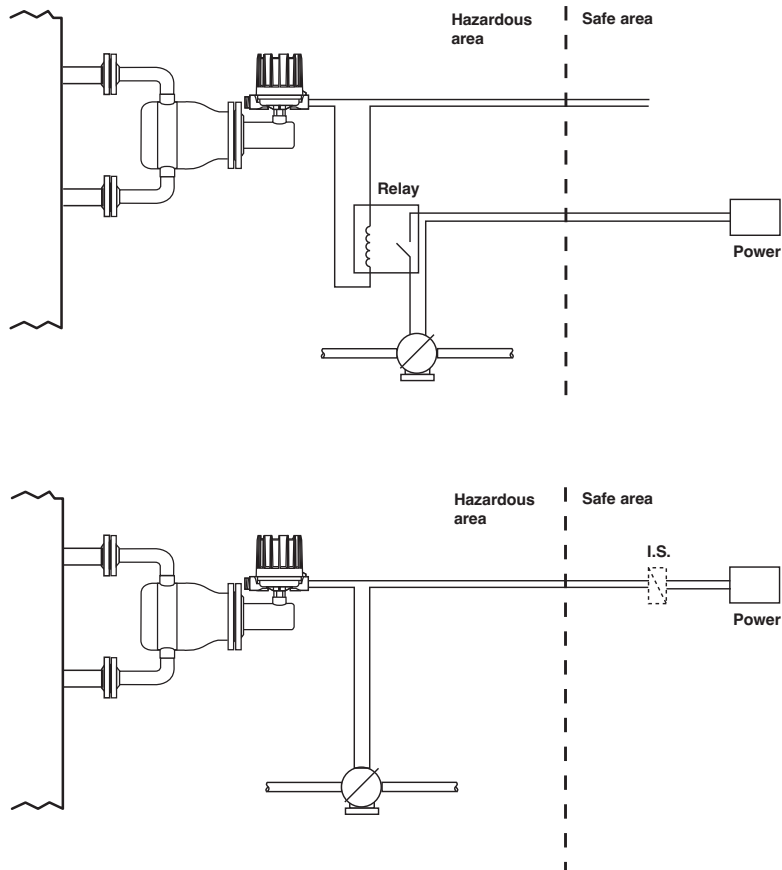

DIMENSIONS in mm (inches)

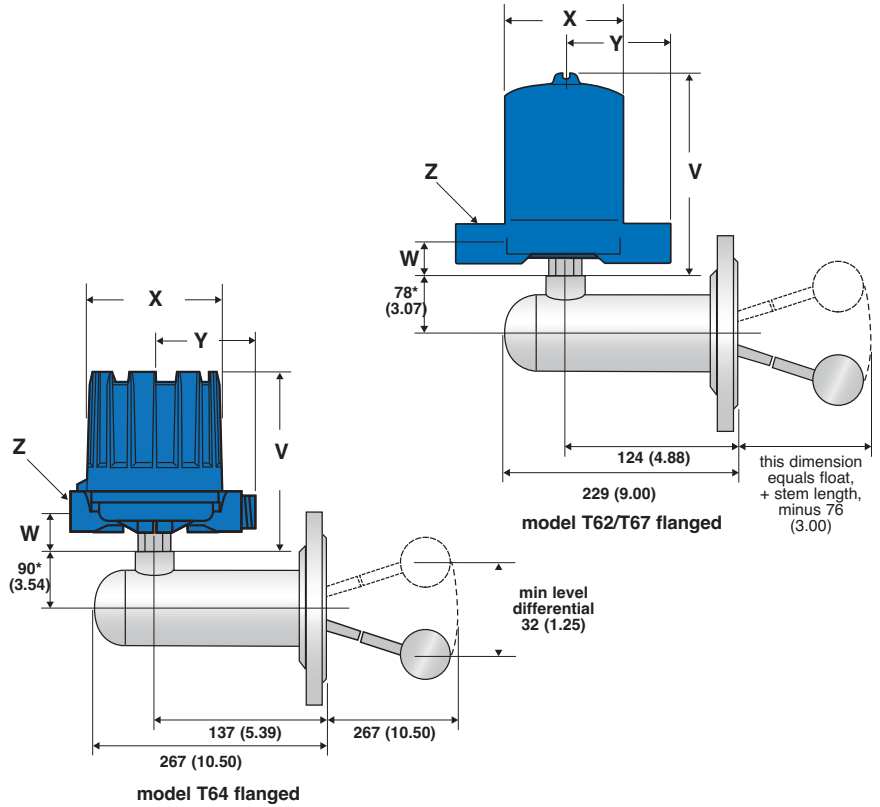
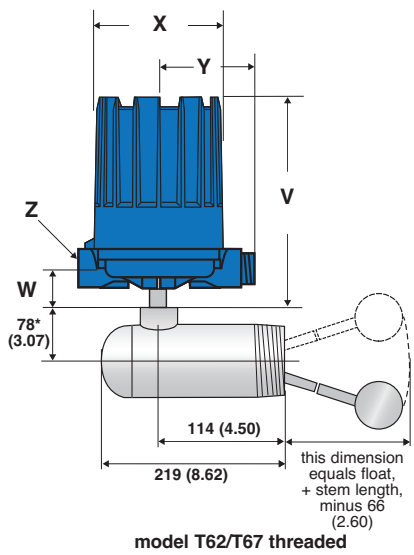

* Dimensions for all housings, except for cast iron housing, add for these 76 mm (3")

Housing type	Models	V		W		ø X		Y		Z
		mm	inches	mm	inches	mm	inches	mm	inches	
Weatherproof-FM (NEMA 7/9) - ATEX (Cast Alu)	T62/T64 with HS-switch and T67	257	10.12	42	1.66	151	5.93	109	4.29	M20 x 1,5 (*) or 1" NPT (2 entries - 1 plugged) (*) not for FM (NEMA 7/9)
	T62/T64 excl. HS-switch	202	7.94							
ATEX (Cast Iron)	All	249	9.80	45	1.77	143	5.63	110	4.33	M20 x 1,5 or 3/4" NPT (single entry - 2 entries at request)
Pneumatics Switch Module J	T62/T64	165	6.50	39	1.54	118	4.65	110	4.33	1/4" NPT
Pneumatics Switch Module K								130	5.12	

Allow 200 mm (7.87") overhead clearance / All housings are 360 ° rotatable



QUALITY ASSURANCE - ISO 9001

THE QUALITY ASSURANCE SYSTEM IN PLACE AT MAGNETROL GUARANTEES THE HIGHEST LEVEL OF QUALITY DURING THE DESIGN, THE CONSTRUCTION AND THE SERVICE OF CONTROLS. OUR QUALITY ASSURANCE SYSTEM IS APPROVED AND CERTIFIED TO **ISO 9001** AND OUR TOTAL COMPANY IS COMMITTED TO PROVIDING FULL CUSTOMER SATISFACTION BOTH IN QUALITY PRODUCTS AND QUALITY SERVICE.

PRODUCT WARRANTY

ALL MAGNETROL MECHANICAL LEVEL CONTROLS ARE WARRANTED FREE OF DEFECTS IN MATERIALS AND WORKMANSHIP FOR 3 FULL YEARS FROM THE DATE OF ORIGINAL FACTORY SHIPMENT.

IF RETURNED WITHIN THE WARRANTY PERIOD; AND, UPON FACTORY INSPECTION OF THE CONTROL, THE CAUSE OF THE CLAIM IS DETERMINED TO BE COVERED UNDER THE WARRANTY; THEN, MAGNETROL INTERNATIONAL WILL REPAIR OR REPLACE THE CONTROL AT NO COST TO THE PURCHASER (OR OWNER) OTHER THAN TRANSPORTATION.

MAGNETROL SHALL NOT BE LIABLE FOR MISAPPLICATION, LABOR CLAIMS, DIRECT OR CONSEQUENTIAL DAMAGE OR EXPENSE ARISING FROM THE INSTALLATION OR USE OF THE EQUIPMENT. THERE ARE NO OTHER WARRANTIES EXPRESSED OR IMPLIED, EXCEPT, SPECIAL WRITTEN WARRANTIES COVERING SOME MAGNETROL PRODUCTS.

BULLETIN: BE 44-116.14
EFFECTIVE: JULY 2021
SUPERSEDES: October 2019

UNDER RESERVE OF MODIFICATIONS

European Headquarters & Manufacturing Facility

Heikensstraat 6

9240 Zele, Belgium

Tel: +32-(0)52-45.11.11

e-mail: info.magnetrolbe@ametek.com

www.magnetrol.com



MAGNETROL®

AMETEK®