

# PD9000 ConsoliDator+

## Multivariable Controller

 ConsoliDator+



PD9000 Installed in a PDA2909 Enclosure



PD9000

## MULTIVARIABLE CONTROLLER

- NEMA 4X Panel Mount Multivariable Controller
- Convenient Display, Control, & Alarm of Multiple 4-20 mA, Pulse, & Modbus Inputs
- Numeric & Bargraph Color Display (320 x 240 pixels) 5.7" (145 mm)
- Sunlight Readable Display, White Backlight
- Isolated 24 VDC Transmitter Supplies 200 mA / Analog Input; 1,600 mA Max
- 99 Channels, 32 Totalizers, 32 Timers, & 199 Modbus Inputs
- 64 High & Low Alarms, Combine Multiple Alarms Into Logic AND & OR Alarms
- Simulation & Manual Control Modes for Testing and Setup
- Modular Design for Inputs & Outputs Flexibility
- Up to (28) 4-20 mA Isolated Inputs or Pulse Inputs
- Up to (25) 10 Amp Form C Relays (With Eight Analog or Pulse Inputs)
- Up to (25) Isolated 4-20 mA Outputs (With Eight Analog or Pulse Inputs)
- Operating Temperature Range: -40 to 60°C (-40 to 140°F)
- Pulse, Analog, & Modbus Input Flow Rate / Total / Grand Total Capability
- 50-Point Linearization, Square Root, and Exponent for Open Channel Flow
- Round Horizontal Tank Volume Calculation; Just Enter Diameter & Length
- Open Channel Flow Math Formulas for Weirs & Flumes
- Multi-Pump Alternation Control or On / Off Control with Random Varying Set Point
- Programmable Displays, Function Keys & Digital Inputs
- Math Functions: Sum, Diff, Average, Multiply, Divide, % Efficiency, & More
- Modbus Client (Master) & Snooper / Server with 99 Programmable Outputs
- Direct Modbus PV Inputs – Snooper / Server Mode
- Modbus Spoofer Feature to Replace Servers Removed from Network
- RS-485 Serial Communication with Modbus RTU / ASCII & Ethernet TCP/IP
- USB Data Logger Feature
- Field Selectable Input Power: 85-264 VAC or 24 VDC
- (20) Screens with up to Eight PVs Each
- Automatic or Manual Scanning
- ConsoliDator+ Configuration Software
- NEMA 4 & 4X Field Mount Enclosures Available
- 3-Year Warranty

**PRECISION  
DIGITAL** 

**PRECISION DIGITAL CORPORATION**

[www.predig.com](http://www.predig.com)



## TABLE OF CONTENTS

OVERVIEW . . . . .	3
SCREENS . . . . .	3
INPUTS & OUTPUTS . . . . .	5
SETTING CHANNEL PARAMETERS . . . . .	6
INDIVIDUAL CHANNEL VIEW . . . . .	7
FREE CONSOLIDATOR+ CONFIGURATION SOFTWARE . . . . .	8
MODBUS CLIENT, SNOOPER & SPOOFER ADD-ON FEATURES . . . . .	13
USB DATA LOGGER ADD-ON FEATURE . . . . .	14
CONNECTIONS . . . . .	18
SPECIFICATIONS . . . . .	21
DIMENSIONS . . . . .	29
ACCESSORIES. . . . .	31
ORDERING INFORMATION. . . . .	33

# PD9000 Multivariable Controller

## OVERVIEW

The ConsoliDator+ is a multivariable controller that is both easy to use and satisfies a wide variety of process display, alarm, and control applications. It accepts 4-20 mA inputs, flow meter pulse inputs, digital inputs, and Modbus inputs and displays them in both numeric and bargraph format on a large, 5.7" color display. It can be equipped with multiple relays with user-definable actions, 4-20 mA outputs, digital outputs, Modbus RTU & ASCII, Modbus Enron, and Ethernet Modbus TCP/IP protocol communication. Additionally, the controller is equipped with up to 32 timers that can be used to control many processes or events.

The ConsoliDator+ takes full advantage of its color display by allowing the user to customize screen colors for bargraphs, alarm conditions, and input channels.

All this functionality is easily programmed using free software or via the front panel pushbuttons. Choose the model that best suits your application, from monitoring only to fully loaded controllers with an extensive combination of inputs, outputs and communication protocols. The standard product offering is listed in the ordering guide and other models are available for special order. The Add-On features expand the functionality of the ConsoliDator+, see the PD9000 manual for details.

## SCREENS

The ConsoliDator+ can be programmed to display the data on up to 20 different screens in a variety of formats and colors, with and without bargraphs. The following screens show a typical main screen and channel details screen:

### Main Screen

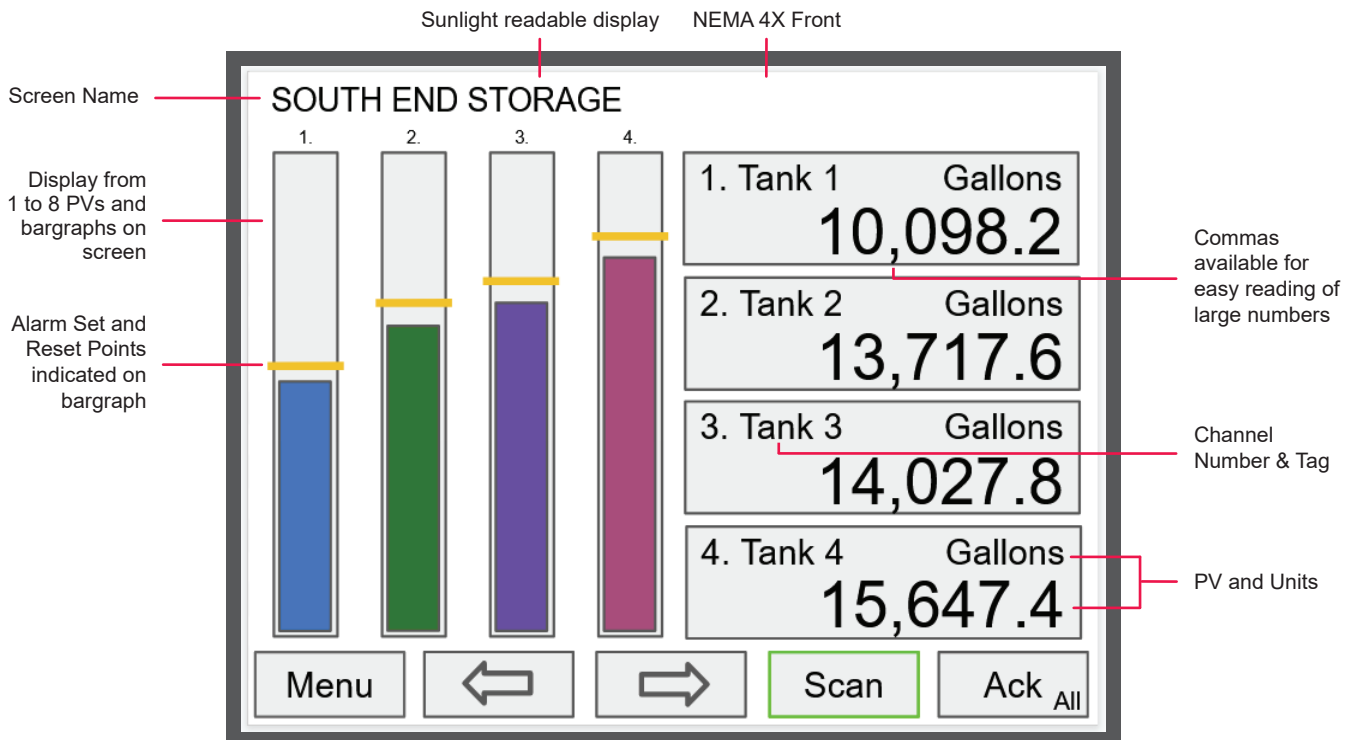

## Channel Details Screen

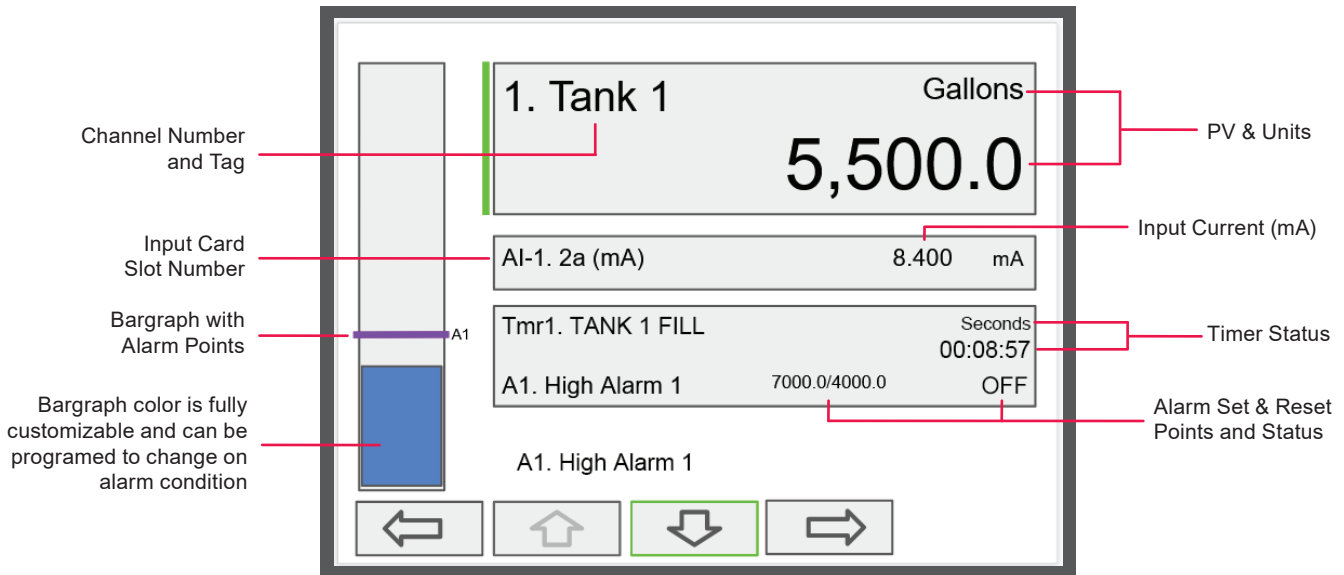

## Screen with Feet & Inches Units

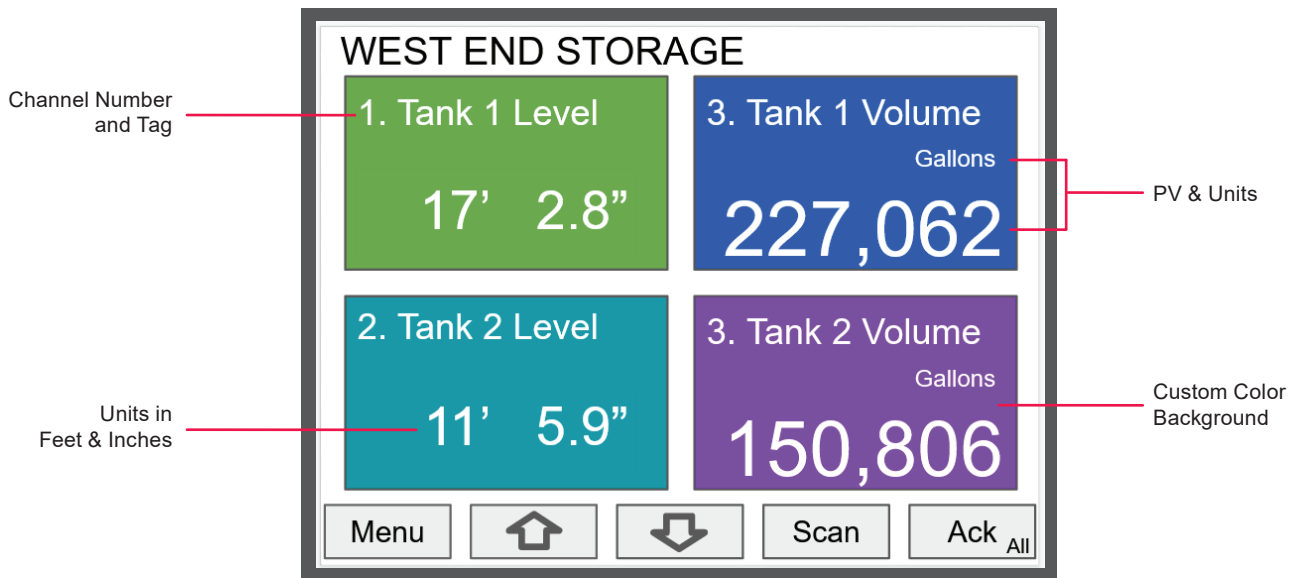

## INPUTS & OUTPUTS

The back panel is labeled with the I/O boards that were installed at the factory. The removable connectors are labeled with the connection signal for each terminal. The following diagram shows what the back of the model PD9000-GP-4PI-8AI-10AO-10RY looks like. This model accepts (4) pulse and (8) analog inputs and has (10) 4-20 mA outputs and (10) relays. (5) digital inputs, (4) digital outputs, RS-485 serial capability and USB connections are standard on all ConsoliDator+ models. Ethernet is an option.

If all Input / Output slots are used exclusively for one function, the ConsoliDator+ can accept up to (28) isolated 4-20 mA inputs, (28) pulse inputs, (25) isolated 4-20 mA outputs, and (25) relays.

If used as a Modbus Client, Snooper, or Server only: It can have (35) 4-20 mA outputs, 30 relays, or (20) 4-20 mA outputs and (15) relays.

All units can be powered from AC or DC; both power connections can be used at the same time. The DC power supply can serve as backup power if the voltage is 24 V or less, otherwise the controller will run on DC power.

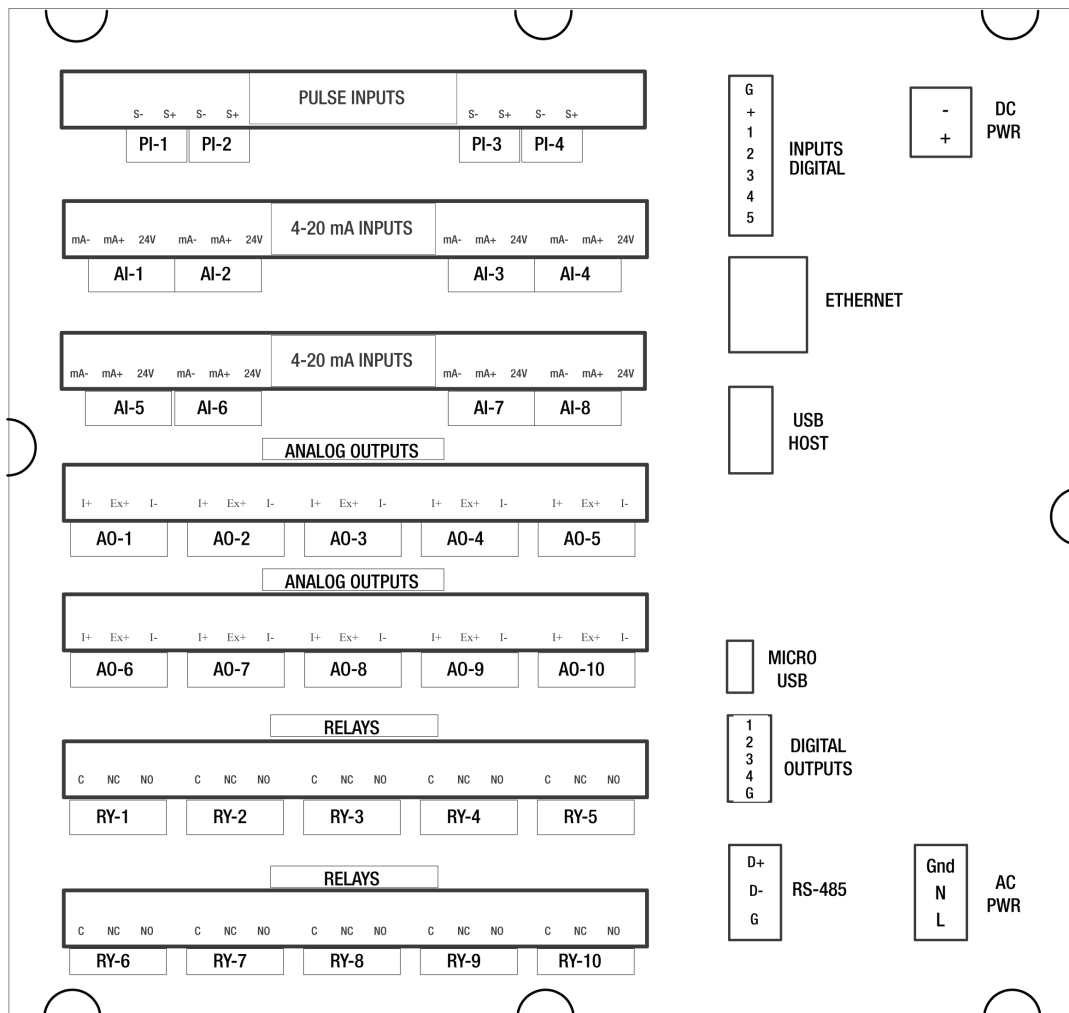

### Notes:

1. Each 4-20 mA input has its own isolated 24 VDC power supply to power the transmitter.
2. Each 4-20 mA output has its own isolated 24 VDC power supply to power the output loop.
3. Each relay is Form C and rated at 10 A.
4. Input / output connections are made to removable screw connectors.
5. Every ConsoliDator+ has five digital inputs (additional digital inputs can be obtained by using the Pulse Inputs).
6. Every ConsoliDator+ has four digital outputs.
7. Every ConsoliDator+ has RS-485 with Modbus.
8. All ConsoliDator+ models can be powered from either AC or DC Power.
9. The USB Host is used for the Data Logger Add-On feature.
10. Ethernet with Modbus TCP is an option.
11. Micro USB is used for programming the ConsoliDator+.



## SETTING CHANNEL PARAMETERS

What makes the ConsoliDator+ easy to program is its intuitive setup screens. As shown in the first image below, the setup screen allows you to see all the relevant information you need when creating or editing a channel - all on one screen! When creating a new channel, the channel number is auto-generated for you. All you have to do is populate the appropriate fields such as the channel tag name, function, input, and units. Scaling the inputs and outputs, selecting number of decimals, and turning the bargraph on/off and inputting its values are also programmed from this screen. Multiple colors can also be selected for the text, background and bargraphs to customize the look of the display screens. During programming, the soft keys will change based on the screen in place. For instance, pressing the edit key will bring up the letters/numbers keypad and appropriate navigation keys will appear (Shown in the bottom image). See the PD9000 manual for details on setup and programming.

**Auto-Generated Channel #:** User-editable to re-order channels

**Channel Tag:** User editable

**Color Pattern Select:** Select color for text, background, and bargraph

**Function:** Applied to input source

**Input:** Source for channel

**Units:** Engineering / time or none

**Decimals:** Number of decimals for PV

**Scale:** Enter input and output values

**Cutoff:** PV goes to zero below the cutoff value

**Display Bargraph:** Display on screen

**Bargraph Scale:** Set the 0 and 100% values

**Soft Keys:** Change based on the screen in place

**Numbers Keypad Button:** pressing this will bring up the numbers keypad

**Text / Numbers Input Field**

**Letter and Numbers Keypad:** Used to input text and numbers in text fields

**Text Field Editing Buttons**

**Soft Keys:** Change based on the screen in place

## INDIVIDUAL CHANNEL VIEW

To view the details of any channel, press Menu and then press View – Channel. Select the channel of interest. Navigate through the different items using the navigation keys. A green bar indicates the selected item, press the R-key to step into and see more details about the inputs and outputs related to the channel in view.

In the following examples, the screens show all the parameters associated with Channel 1 including analog input, slot number and its current value, setpoints and status of alarms, and analog output and its mA value. The bargraphs in each of these screens examples represent the current value in gallon units.

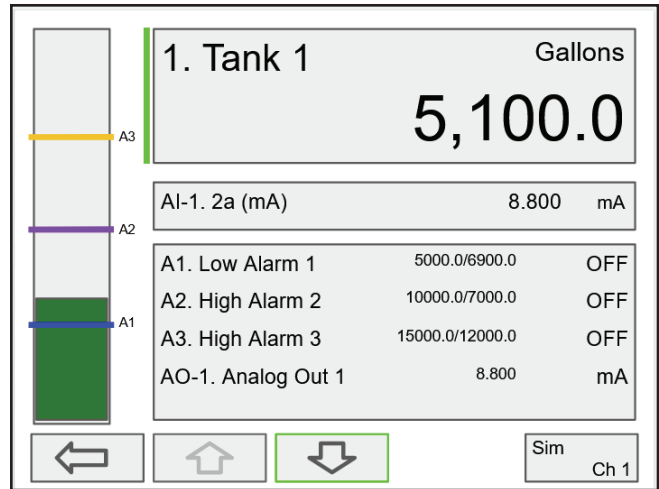

Alarm set points are indicated by horizontal lines.

## Low & High Alarm Indication

If applicable, alarms may be acknowledged, and totals may be reset from the channel view screens. The alarm set points are indicated by a line at the corresponding value on the bargraph. Color selection for alarm conditions can be done in the Setup – Alarm menu or in the System – Display menu.

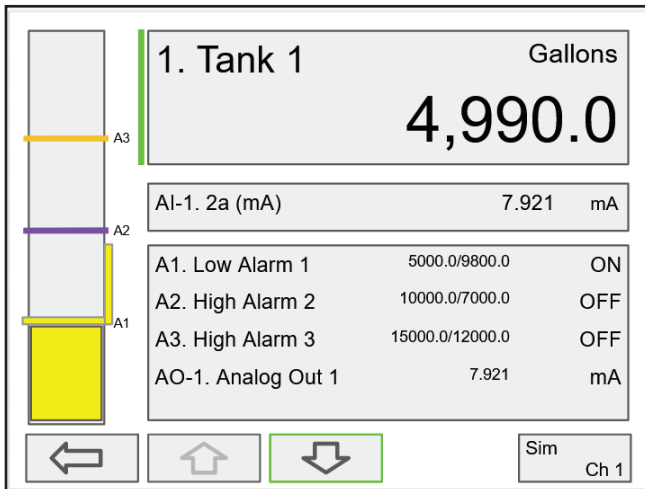

**Active Low Alarm:** Indicated by horizontal and vertical lines. The top of the vertical line is the reset point of the low alarm. The low alarm is indicated on the right side of the bargraph.

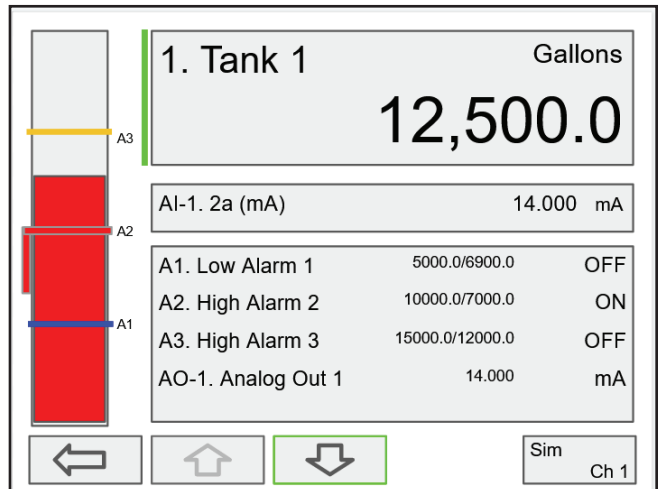

**Active High Alarm:** Indicated by horizontal and vertical lines. The bottom of the vertical line is the reset point of the high alarm. The high alarm is indicated on the left side of the bargraph.

# PD9000 Multivariable Controller

## FREE CONSOLIDATOR+ CONFIGURATION SOFTWARE



The easiest and quickest way to program your ConsoliDator+ multivariable controller is to use the FREE ConsoliDator+ configuration software.

The ConsoliDator+ configuration software is intuitive, and most customers can get their controller programmed as they like without even looking in the manual.

Once your controller is programmed the way you want it, you can wire it up for your application per the instructions in this manual and install it. If you find that you need to adjust the programming after the controller is installed, you can use the front panel soft keys and the instructions in the manual to do so.



### Channel Settings

- Enter Display Tag Name for Channel
- Select a Function
- Select Input
- Select Units
- Select Decimal Position
- Select Color Scheme for Text, Background, and Bargraph
- Check Box to Display Bargraph
- Enter Scaling for Bargraph

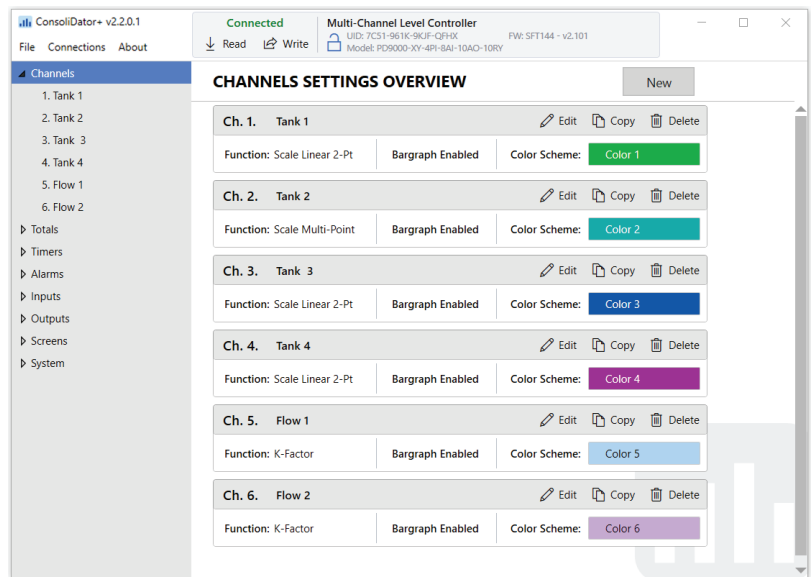



## Totals Settings

- Enter Display Tag Name for Total
- Select Input
- Enter Units
- Enter K-Factor Value
- Set Decimal Point
- Check Box for Countdown, Allow Negative, Preset Value and Enter Value, Roll-Over and Enter Value, and Non-Resettable
- Select a Color Scheme for Text, Background, and Bargraph
- Check Box to Display Bargraph
- Enter Scaling for Bargraph

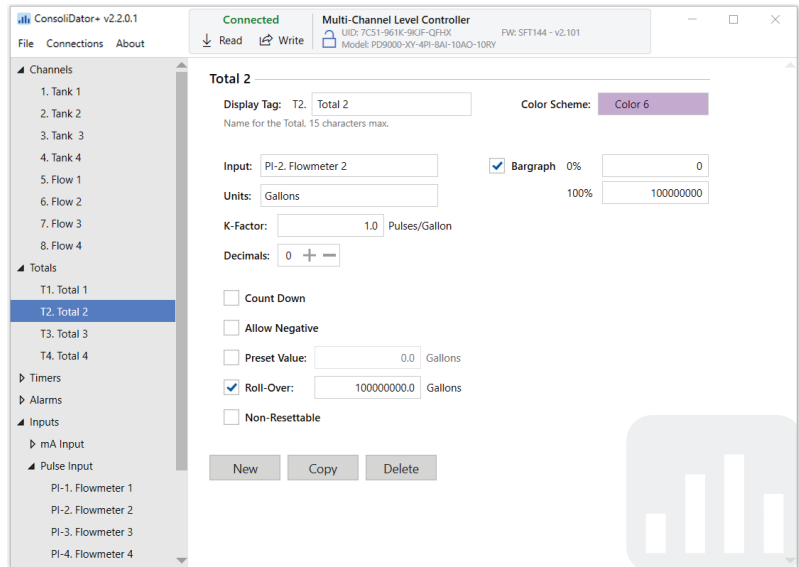

## Timers Settings

- Enter Display Tag Name for Timer
- Select Input
- Select Power Up Option
- Select Error Option
- Select Reset Option and Enter Value
- Select Start Option and Enter Value
- Select Stop Option and Enter Value
- Set Decimal Point
- Select Color Scheme for Text, Background, and Bargraph
- Check Box to Display Bargraph
- Set Scaling for Bargraph

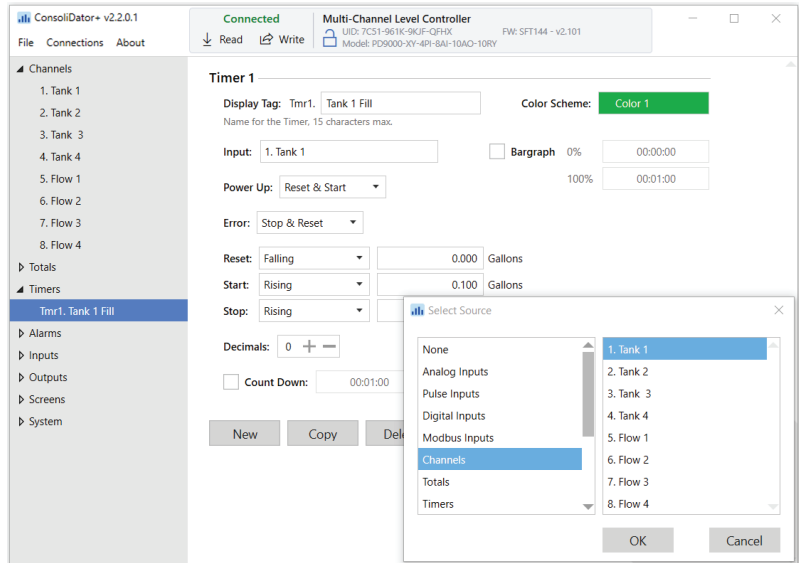

## Alarm Settings

- Enter Display Tag Name for Alarm
- Select Alarm Type
- Select Input
- Enter Set and Reset Points
- Select Color Scheme for Text, Background, and Bargraph
- Check Box to turn On/Off Sound Horn, Alert!, Automatic, or Ack Anytime
- Select Break: Alarm Off, Alarm On, Stay As Is
- Enter Value for On Delay and Off Delay
- Enter Name for Alarm Color Profile
- Check Box for Alarm to Flash

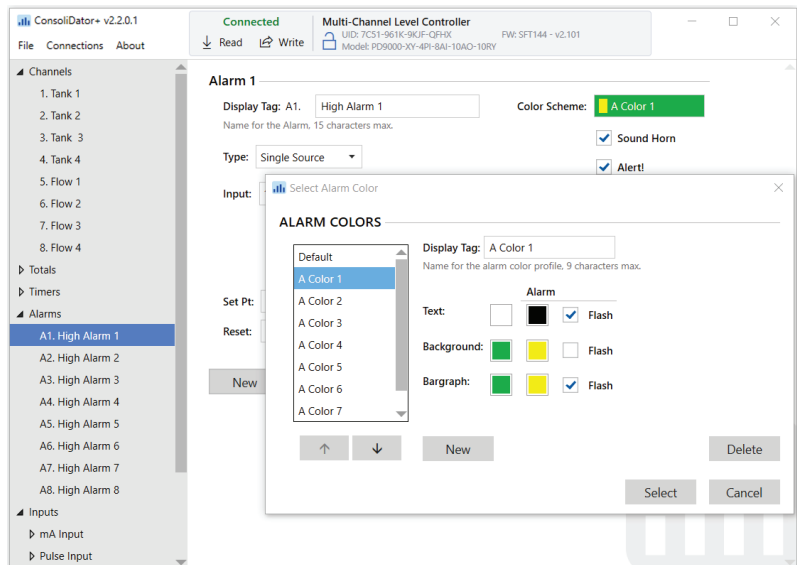

# PD9000 Multivariable Controller

## Inputs Settings

- Enter Display Tag Name for Input Channel
- Select Filter Time
- Enter Bypass Value
- Check Box for Glitch Filter
- Check Box for Break Below and Set mA Value
- Check Box to Disable Input Channel

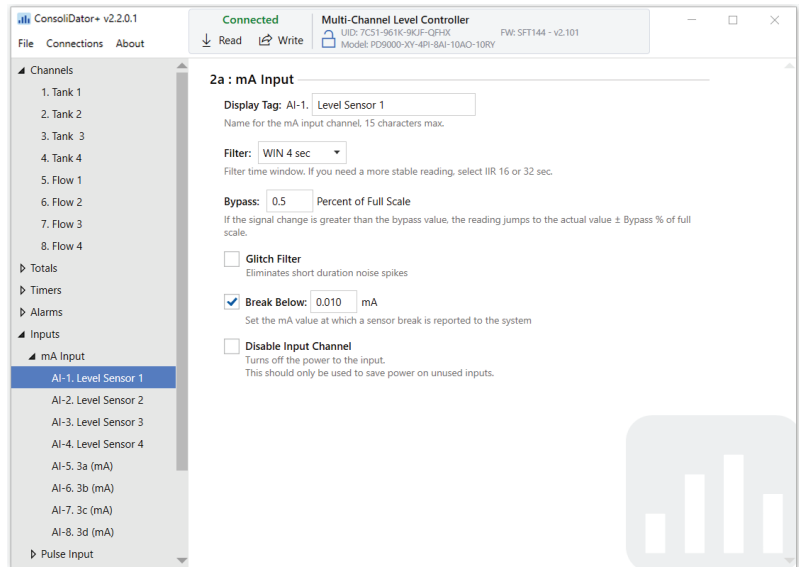

## Outputs Settings

- Enter Display Tag Name for Output Channel
- Select Input Source
- Check Box for Fail-Safe

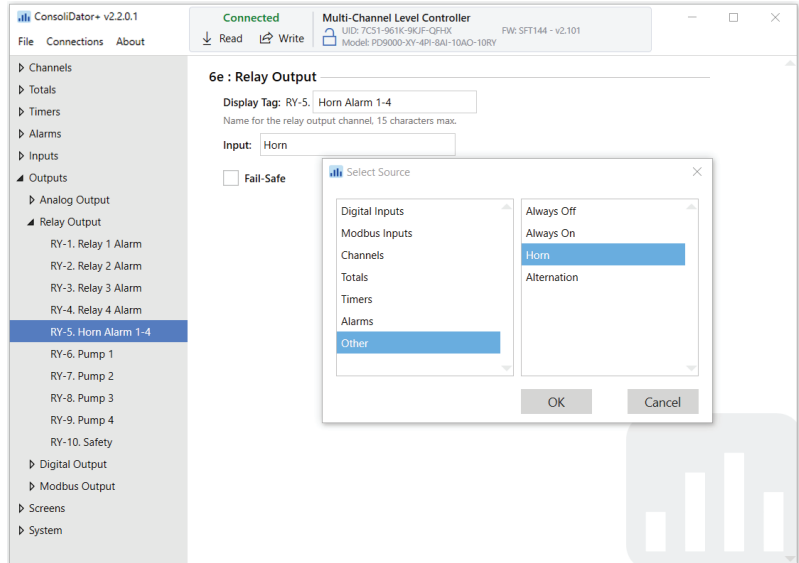

## Screens Settings

- Enter Title Name for Screen
- Check Box to Show Title
- Check Box to Show Channel Number
- Check Box to Display Bargraph and/or Bargraph Only
- Check Box to Auto Scan
- Check Box for Dwell Time and Enter Dwell Time

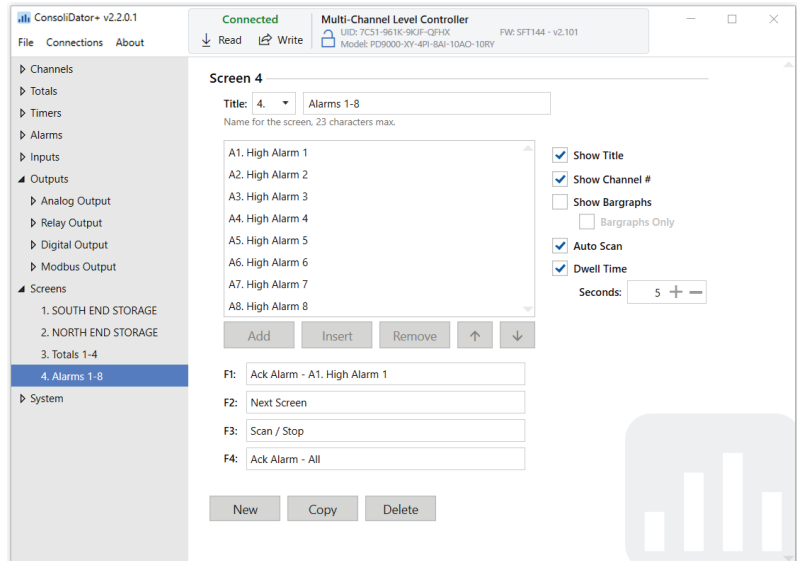

# PD9000 Multivariable Controller

## System Display Settings

- Set Backlight Brightness
- Enter Display Refresh Rate
- Check Box to Show Commas
- Select Color Scheme for Text, Background, and Bargraph
- Check Box to Show Alarm Condition Using Alarm Color Settings

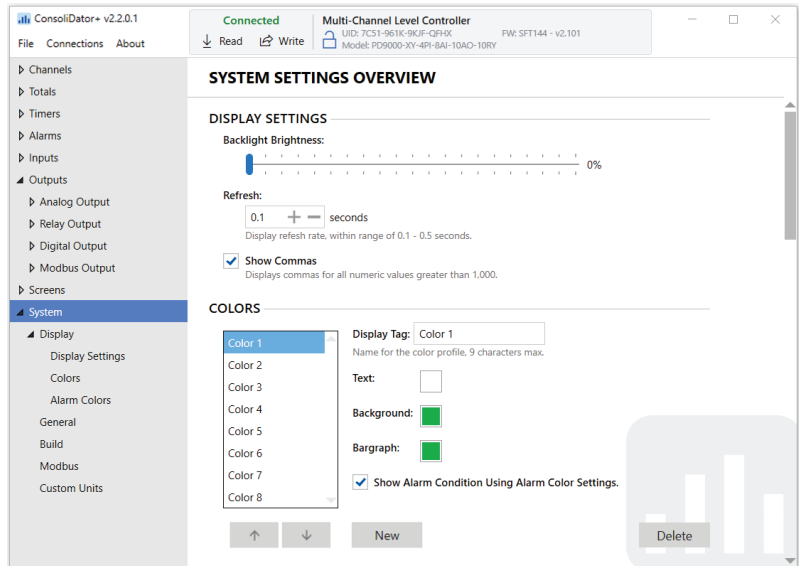

## General / Date & Time Settings

- Enter Device Tag Name
- Check Box for Enable Buzzer and Select Buzzer Sound
- Set Date and Time or Check Box to Use System Date and Time
- Click on the Gray Buttons to Load Defaults, Set Password, or Clear Password

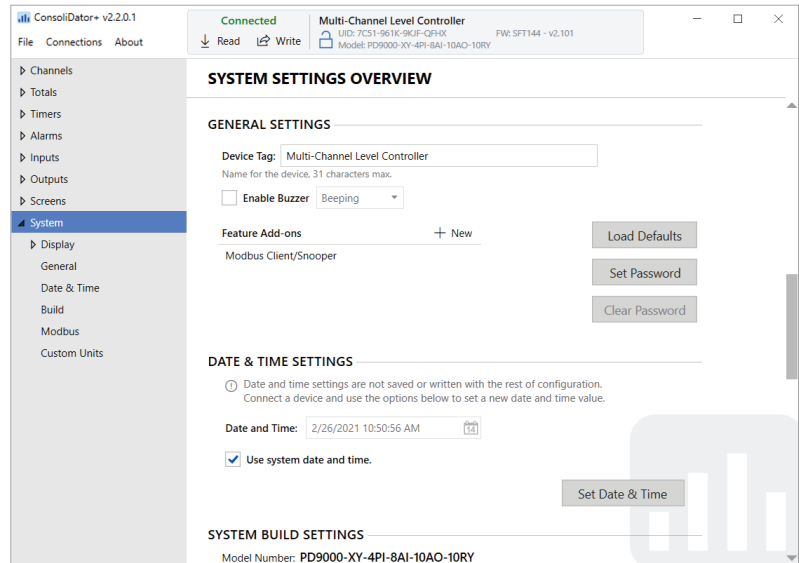

## System Build Settings

- Shows Model Number of the Connected Controller
- Shows Slot Numbers and Input/Output Cards Installed on the Connected Controller

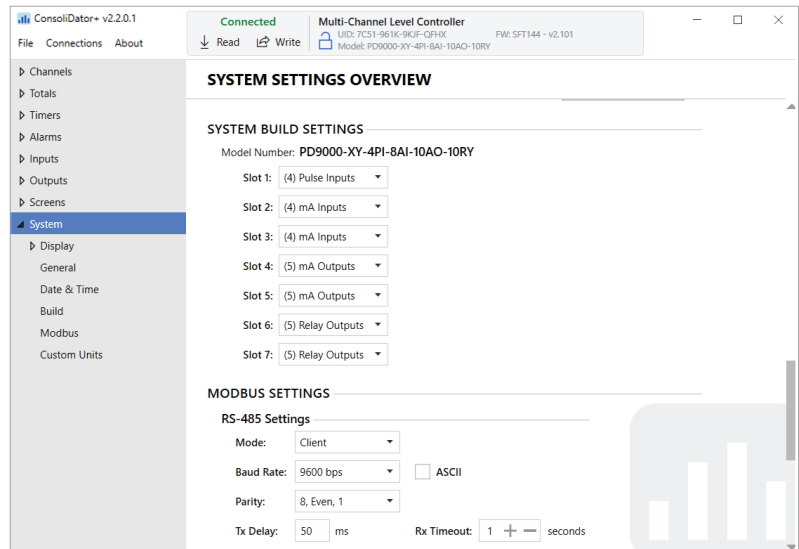

# PD9000 Multivariable Controller

## Modbus Settings

- Select Modbus Mode
- Select Baud Rate
- Select Parity
- Enter a Value in ms for Tx Delay
- Click on the Plus or Minus Symbol to Increase or Decrease Seconds for Rx Timeout
- Check the Box for Passcode and Enter a Number to Protect the Server Settings

**SYSTEM SETTINGS OVERVIEW**

**MODBUS SETTINGS**

**RS-485 Settings**

Mode: Client

Baud Rate: 9600 bps  ASCII

Parity: 8, Even, 1

Tx Delay: 50 ms Rx Timeout: 1 seconds

**Server Settings**

Passcode: 0

**CUSTOM UNITS SETTINGS**

Name	Unit Type	Unit Base	Factor
MGal	Volume	Gallons	0.000001
Box24	Count	Pulses	0.041667
PASSED	Logic		
FAILED	Logic		

## Custom Units Settings

- View or Add Custom Units
- Enter a Label for Unit
- Select a Unit Type
- Select Unit Base
- Enter a Value for Factor

**CUSTOM UNITS SETTINGS**

Name	Unit Type	Unit Base	Factor
MGal	Volume	Gallons	0.000001
Box24	Count	Pulses	0.041667
PASSED	Logic		
FAILED	Logic		

New Delete Edit

## MODBUS CLIENT, SNOOPER & SPOOFER ADD-ON FEATURES

The ConsoliDator+ Multivariable Controller supports Modbus RTU, Modbus ASCII, Enron Modbus, and Ethernet Modbus TCP/IP. The Server mode is a standard ConsoliDator+ feature; it responds to requests and accepts writes from a Modbus client.

The ConsoliDator+ is now available with Modbus Client, Snooper, and Spoofer capabilities and has the ability to scan and display up to 199 Modbus registers. This feature can be “unlocked” on any ConsoliDator+ purchased after February 15, 2021 by purchasing the [PDK9000-M1](#) Key for \$500 and entering the Key value into the ConsoliDator+.

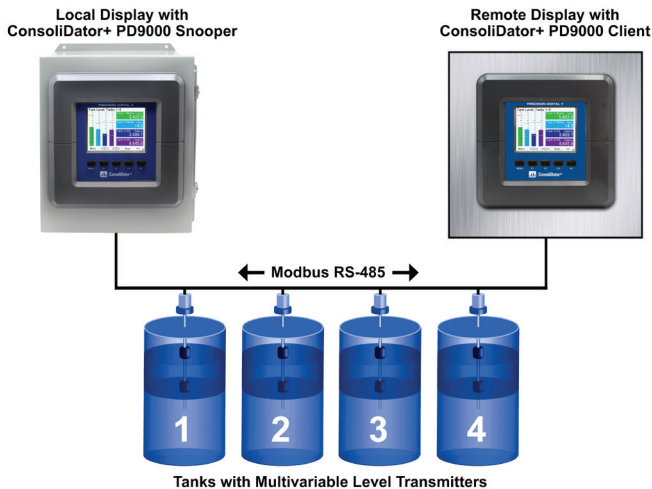

### Client Mode

The Client mode can request process variables from server devices; the input variables can be scaled, combined with other variables using math functions, and they can be written to other server devices using the Modbus output functions. The controller can request up to 199 Modbus values, as inputs from other Modbus devices. The inputs can be used as the source for channels, math functions, alarms, relay control, etc.

MB-1.	MB Input 1	Client
Server ID:	247	Address: 0
Function Code:	03	<input type="checkbox"/> Enron
Type:	Float 32	Reg. No. 40001, 40002
Byte Order:	ABCD	
Units:	Gallons/min	Decimals: 2
Break:	Default	Default: 0.00 Gallons/min
<input checked="" type="checkbox"/> Poll Time:	5.0 seconds	<input checked="" type="checkbox"/> Timeout: 00:00:10
Input Action:	Add To T1. Total 1	
<input type="button" value="Cancel"/> <input type="button" value="Home"/> <input type="button" value="Down"/> <input type="button" value="Edit"/> <input type="button" value="Save"/>		

### Snooper Mode

The Snooper mode can listen and read the process variables being transmitted on the RS-485 bus without causing any disruptions to the network. The controller can read up to 199 Modbus values, as inputs from other Modbus devices being polled by a Modbus Client. The inputs can be used as the source for channels, math functions, alarms, relay control, etc.

MB-3.	MB Input 3	Snooper
Server ID:	1	Address: 0
Function Code:	03/06	<input type="checkbox"/> Enron
Type:	Float 32	Reg. No. 40001, 40002
Byte Order:	ABCD	
Units:	Gallons/min	Decimals: 2
Break:	Default	Default: 0.00 Gallons/min
<input checked="" type="checkbox"/> Timeout:	00:00:15	
Input Action:	None	
<input type="button" value="Cancel"/> <input type="button" value="Home"/> <input type="button" value="Down"/> <input type="button" value="Edit"/> <input type="button" value="Save"/>		

### Spoof Mode

The Spoofer mode is designed to replace existing Modbus Servers without requiring changes to the Client configuration. Each process value can be assigned a specific Device ID and Register Number to mimic the original server configuration.

MO-1.	MB Output 1	Spoof
Input:	Total 1	
Server ID:	9	Address: 0
Function Code:	03	<input checked="" type="checkbox"/> Enron
Type:	Float 64	
Byte Order:	ABCD	
Units:	Gallons	Decimals: 1
Output Action:	Reset Total - Total 1	
<input type="button" value="Cancel"/> <input type="button" value="Home"/> <input type="button" value="Down"/> <input type="button" value="Edit"/> <input type="button" value="Save"/>		

See the PD9000 ConsoliDator+ manual for details on the Modbus Add-On features.



## USB DATA LOGGER ADD-ON FEATURE

The [PDK9000-D1](#) Data Logger Add-On Feature for the PD9000 ConsoliDator+ allows you to log data to an external USB flash drive and create logs that contain the same type of process data or a mix of just about anything you might want to log. Each log can contain up to 12 process variables, inputs, outputs, timers, alarm status, relay status or a combination of parameters such as mA inputs, digital inputs, Modbus inputs, channels, totals, timers, and more. The data logger can be controlled in many ways; the start/stop, enable switch, log trigger, or log interval. See the PD9000 instruction manual for more details.

The [PDK9000-D1](#) Data Logger Add-On feature that is ordered with the ConsoliDator+ will be activated at the factory. This Add-On feature can be ordered for existing ConsoliDator+ units with a firmware version 2.2 or greater, at any time. The user will receive a key they can enter into the ConsoliDator+ to unlock the Add-On feature.

### Setup Data Log

The *Setup Data Logs* menu is used to configure settings that are used for logging data to an external USB flash drive. Any data parameter can be logged; up to 8 data logs can be created. Each data log can contain from 1 to 12 parameters.

#### Setup New Data Log

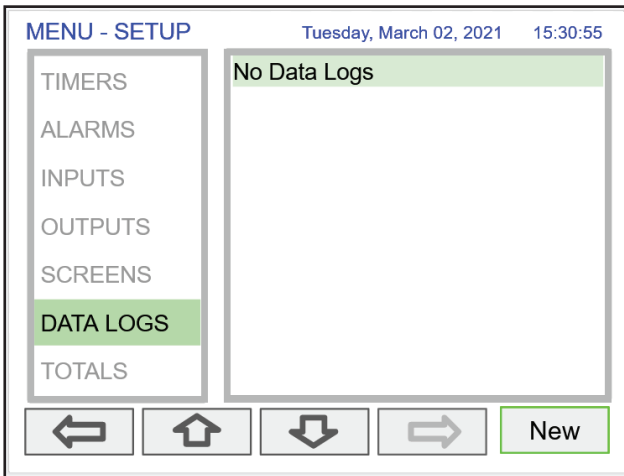

The setup of the data logs is easy, intuitive, and flexible. You can create logs that contain the same type of process data or you can have a mixed of just about anything you might want to log.

- Navigate to the *Data Logs* menu
- Press the *New* key (F4) to create a new log
- An untitled log is created

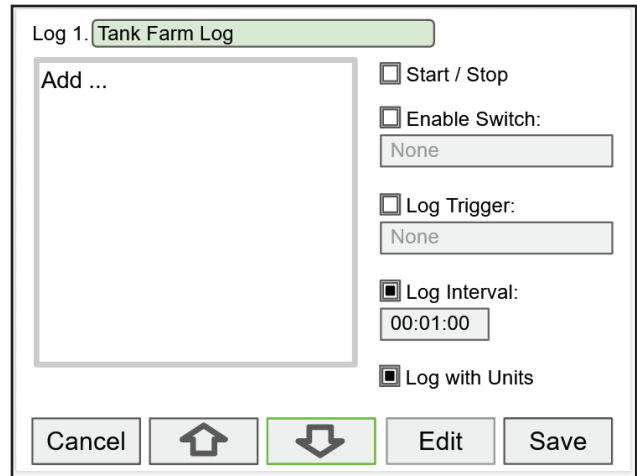

- Log #: Enter log file name
- Add: Add items to be logged
- Start / Stop: Control the log start & stop
- Enable Switch: Select an additional log control
- Log Trigger: Trigger log on a specific event
- Log Interval: Log at the specified interval
- Log with Units: Each log entry will have the corresponding engineering units

### CAUTION

Do not change the units for totals, while the data logger is running; the accumulated total will not be converted to the new units and the reflected value will not be accurate.

#### Add Items to Be Logged

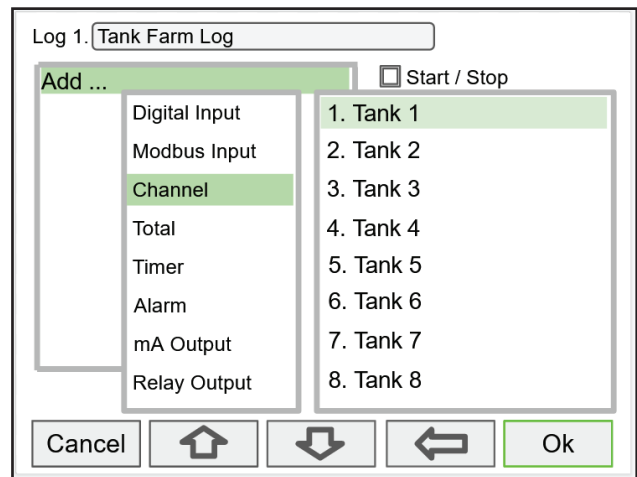

Each log can contain up to 12 process variables, inputs, outputs, timers, alarm status, relay status, or a combination of any of the following parameters:

- |                   |                     |
|-------------------|---------------------|
| 1. mA Inputs      | 7. Alarms           |
| 2. Digital Inputs | 8. mA Outputs       |
| 3. Modbus Inputs  | 9. Relay Outputs    |
| 4. Channels       | 10. Digital Outputs |
| 5. Totals         | 11. Modbus Outputs  |
| 6. Timers         |                     |

See the PD9000 ConsoliDator+ manual for details on the Modbus Add-On features.

## Setup Log Start / Stop

The log *Start / Stop* is used to give the system or the operator control to start and stop the log process.

The *Start / Stop* function is available in the View Log menu via the function keys.

The *Start / Stop* function can be activated with:

- Screen F1-F4 function keys
- Digital inputs
- Modbus inputs
- Modbus outputs
- Channel Control: Schedule, Sampler

## Setup Log Enable Switch

The log *Enable Switch* can be any item with a binary value (on / off, 0 / 1, true / false). Log entries will be made only if the *Enable Switch* is in the on position.

The *Enable Switch* input can be:

- Digital input
- Modbus input
- Channel
- Alarm
- Relay Output

## Setup Log Trigger

The *Log Trigger* can be any event from the list below. Log entries will be made every time the input is activated.

The *Log Trigger* input can be:

- Digital input
- Modbus input
- Channel
- Alarm
- Relay Output

The Modbus outputs can be used to trigger log entries.

## Setup Log Interval & Log Units

The *Log Interval* can be from 1 sec to 99:59:59 hh:mm:ss. Log entries will be made at the selected interval.

In this example the log must be started, and the digital input 1 must be on to log the tanks volume every minute.

To log continuously without the need to start or enable the log, deselect the *Start / Stop* and the *Enable Switch* settings. If engineering units are not needed, deselect the *Log with Units* setting.

### **CAUTION**

If *Start / Stop* is enabled, the log will stop on a power cycle. Make sure to monitor if the power is turned off and re-start the log when the power is turned on.

## Setup USB Drive

System - USB Drive

USB Drive: Ready

Capacity: 15630139392 bytes

Used Space: 22216704 bytes

Free Space: 15607922688 bytes

Stop when Full

Remove Device

← ↑ ↓ □

The *System – USB Drive* provides status information about the connected flash drive.

- USB Drive Status
- Capacity
- Used Space
- Free Space

*Stop when Full*: This should be selected, if the oldest logged data is more important than logging new data.

If *Stop when Full* is not selected, the oldest block of data will be deleted to make room for new data.

### IMPORTANT

The USB Drive menu is available only through the front panel.

## Safely Remove Flash Drive

System - USB Drive

USB Drive: Ready

Capacity: 15630139392 bytes

Used Space: 22216704 bytes

Free Space: 15607922688 bytes

Stop when Full

Remove Device

← ↑ ↓ Remove

To safely remove the flash drive:

Go to the *System – USB Drive* screen, navigate to the *Remove Device* button using the down arrow key, then press the Remove key.

This procedure allows the USB drive to finish writing any log data in progress and prevent the lost or corruption of data.

## View Data Logs

In the *View Data Logs* menu you can see a list of the active data logs. Press the right arrow key to go to the log list and to see details of any of the logs.

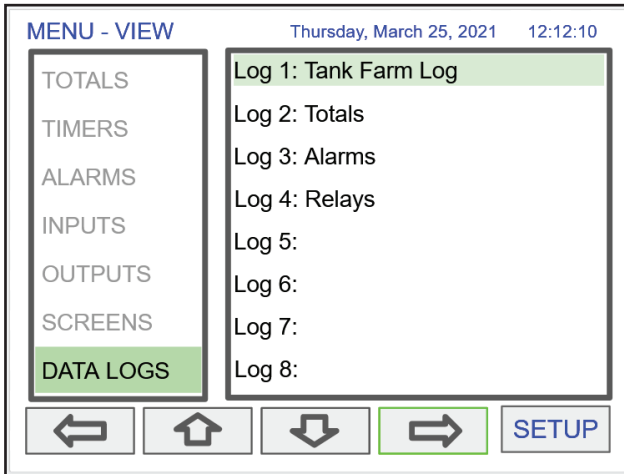

The screen below shows a snapshot of the log in progress. If the log is not running, the screen will only show the log # and name. Press *Start Log* followed by *Log Entry* to capture the first log.

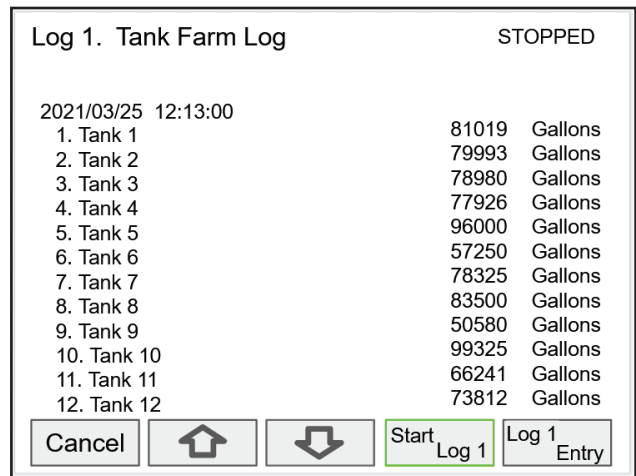
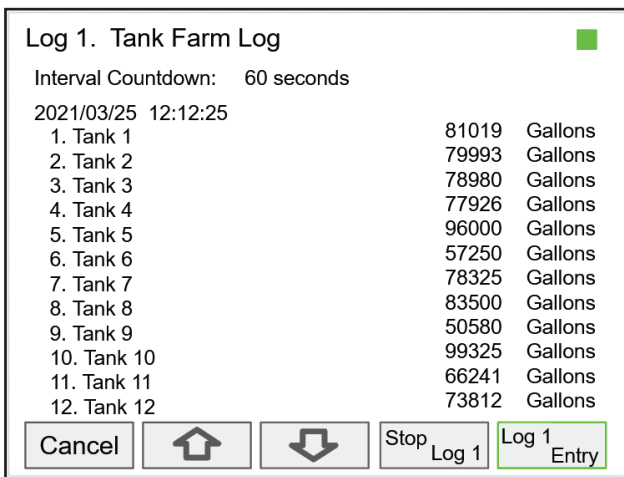

Press the *Stop Log* key to stop logging the selected log.

The *Start / Stop* function can be enabled or disabled during the log setup. This function is independent for each log.

After the log is started, the system will capture the first log according to the log setup selected.

The *Log Entry* key allows the user to capture a snapshot of the process any time.

### IMPORTANT

There is no provision for viewing previous log records on the screen. The flash drive must be removed and connected to a computer to download the saved logs.

## CONNECTIONS

Power connections are made to one of the power terminal connectors. All units are capable of being powered either by AC or by DC for the ranges specified.

### 90-264 VAC Power

- Use three-terminal power connector as shown in Figure 1.
- Unit is protected internally with 1.25 A auto-resettable fuse. 2 A max, slow blow, 250 V min UL Recognized external fuse recommended.

### 24 VDC Power $\pm$ 10%

- Use two-terminal power connector as shown in Figure 1.
- Unit is protected internally with 3.7 A auto-resettable fuse. 4 A max, slow blow, 50 V min UL Recognized external fuse recommended.

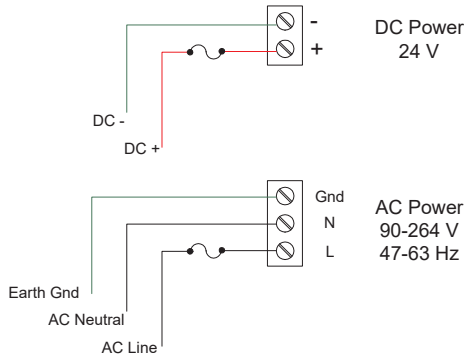

Figure 1. Power Connections

**Note:**

The controller may be powered by AC voltage with the 24 VDC power connection used as backup power.

### Isolated Input Signal Connections

Isolated input signal connections are made to removable screw terminal connectors, which are labeled individually on the back panel of the controller. The back panel shows the type of input card installed in each slot (The top slot is #1 and the bottom is #7). Individual inputs are referenced as PI-1 to PI-4 for pulse inputs and AI-1 to AI-4, AI-5 to AI-8, etc for analog inputs.

### 4-20 mA Analog Input Connections

Analog 4-20 Input connections are made to screw terminal connectors (two inputs per connector). The following figures show examples for typical applications. Each of the 4-20 mA inputs may be connected in any of the modes shown below.

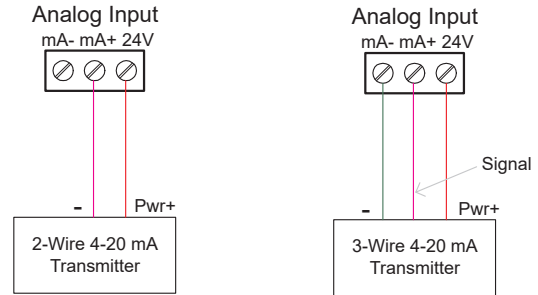

Figure 2. Transmitters Powered by ConsoliDator+'s Isolated 24 VDC Power Supply

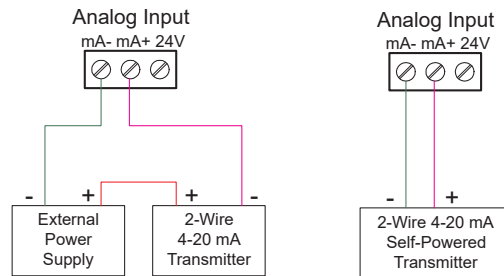

Figure 3. Transmitter Powered by External Supply or Self-Powered

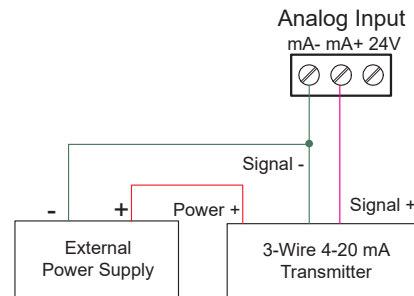

Figure 4. Three-Wire Transmitters Powered Externally



## Flow Meter Pulse Input Connections

Flow Meter Pulse Inputs are wired to four-terminal connectors (two inputs per connector). A square waveform is used in the illustration, but the input is capable of reading many other types of signals within the voltage and frequency ranges specified.

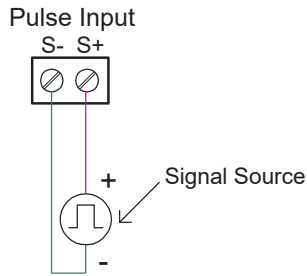

Figure 5. Flow Meter Pulse Input Connections

## Digital Input Connections

Inputs are wired between terminals 1-5 of the digital input connector and the G terminal of the 2-position connector above the digital inputs. Normally open switch contacts may be used as shown in Figure 6. The diagram also shows a Digital Input using an NPN open collector transistor output from a live signal. Logic LO or switch closure appearing across the terminals is interpreted as ON. When using an open collector transistor, a logic HI at the base (marked "B" in Figure 6) will be interpreted as ON. The 2-position connector has a +5 V terminal that may be used to provide excitation to some sensors requiring more than the pull-up provided on each digital input terminal.

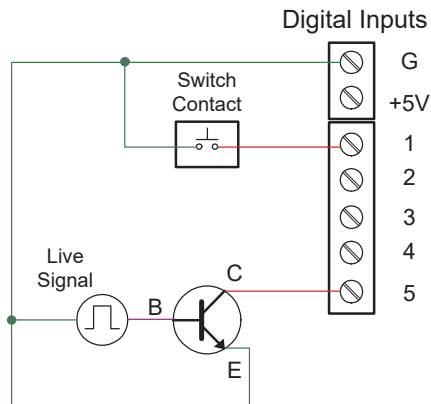

Figure 6. Digital Input from Switch Closure and Live Signal

## Analog Output Connections

The following figures show examples for isolated 4-20 mA transmitter output connections. Terminal connectors are labeled individually. The analog outputs are isolated from each other and from the inputs. They are powered internally to provide an active 4-20 mA output loop. The outputs may be powered externally by connecting the positive voltage to the Ex+ terminal.

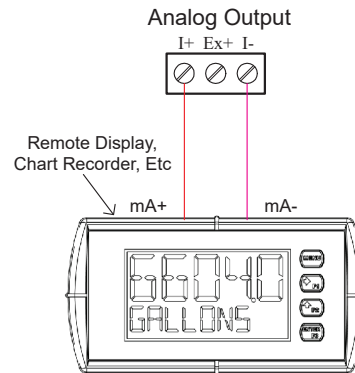

Figure 7. Active 4-20 mA Output Powered by ConsoliDator+

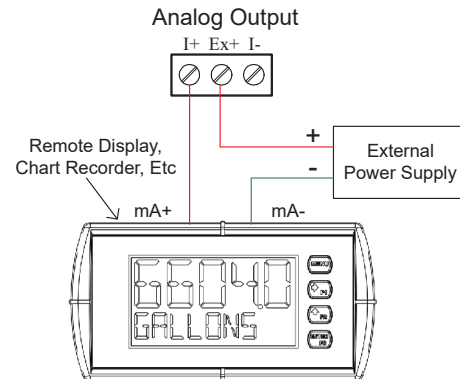

Figure 8. Passive 4-20 mA Output Powered by External Supply

*Note: Analog inputs and outputs are isolated from each other.*

## Digital Output Connections

The digital outputs may be used to drive digital inputs, alarm annunciators, or other devices such as solid state relays that can be driven with low voltage signals.

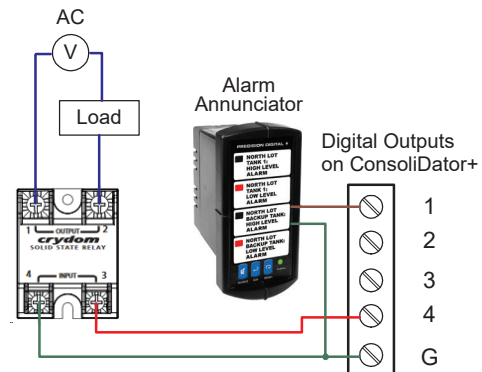

Figure 9. Digital Outputs Driving 5V Solid State Relay and Alarm Annunciator

## Relay Connections

Relay connections are made to three-terminal connectors labeled individually. There are five relays per card.

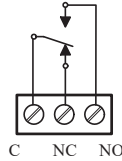

Figure 10. Relay Connections

## Switching Inductive Loads

The ConsoliDator+ has internal circuitry to protect the relays from inductive loads, however, the use of suppressors (snubbers) is strongly recommended when switching inductive loads to prevent disrupting the microprocessor's operation. The suppressors also prolong the life of the relay contacts. Suppression can be obtained with resistor-capacitor (RC) networks assembled by the user or purchased as complete assemblies. Refer to the following circuits for RC network assembly and installation.

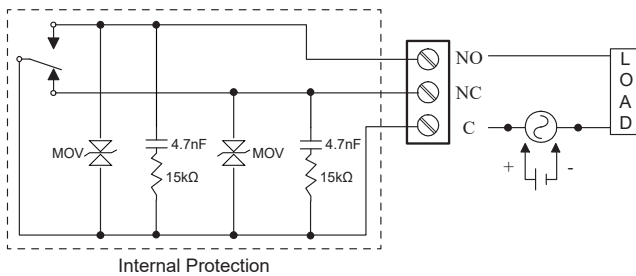

Figure 11. AC and DC Internal Inductive Load Protection

For additional external protection choose R and C as follows:

- R: 0.5 to 1  $\Omega$  for each volt across the contacts
- C: 0.5 to 1  $\mu\text{F}$  for each amp through closed contacts

### Notes:

1. Use capacitors rated for 250 VAC.
2. RC networks may affect load release time of solenoid loads. Check to confirm proper operation.
3. Install the RC network at the instrument's relay screw terminals. An RC network may also be installed across the load. Experiment for best results.

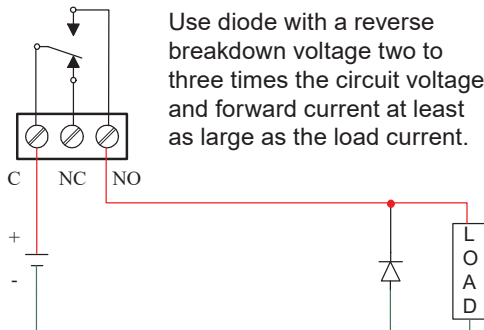

Figure 12. Low Voltage DC Loads Protection

## RC Networks Available from Precision Digital

RC networks are available from Precision Digital and should be applied to each relay contact switching an inductive load. Part number: PDX6901.

## Serial Communication Connections

The RS-485 port for serial communication (using Modbus protocol) has three terminals labeled D+, D-, and G. It is strongly recommended to use three-wire shielded cable and to always connect the ground terminal to the other equipment's ground to avoid differential voltage between the systems. Distances up to 4000 feet can be reached with RS-485. Up to 32 Modbus devices may be connected to a single RS-485 bus.

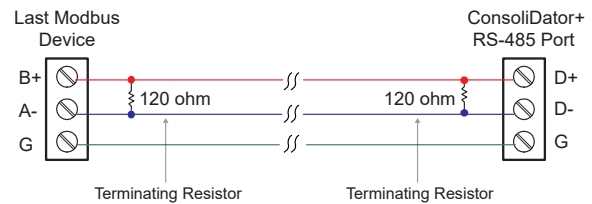

Figure 13. Serial Connections

## Ethernet Option

The Ethernet port is available on the RJ45 connector. This allows the ConsoliDator+ to connect to a local area network. The Ethernet port option is configured using the System menu. See the [PD9000 ConsoliDator+ manual](#) for ethernet port setup details.

## External Keypad Connections

Normally open pushbuttons may be wired to the digital inputs connector for use when the front panel of the controller is not accessible. The external keys may be assigned to replicate the Menu and F1-F4 function keys.

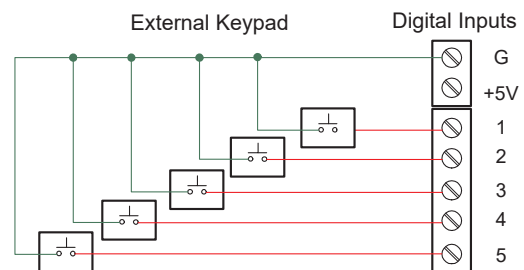

Figure 14. External Keypad Connections

## SPECIFICATIONS

Except where noted all specifications apply to operation at 25°C (77°F)

### General

**Display:** Color: QVGA (320x240 pixels), 5.7" (145 mm) diagonally, white backlight; Bargraph: Twenty divisions Numerical: Up to 15 digits ( $\pm 999,999,999,999,999$ ); Feet & Inches Format: 99,999' 11.9"

**Screen Bargraph:** Enable/disable: Channels, totals, timers Bargraph scale: 0 – 100%, independent of channel scale. Twenty divisions: 5% each. Screen: Select to show bargraph or not.

**Color Selection:** 65 colors selection, Customize bargraph, panel background, and text for normal and alarm conditions.

**Decimal Point:** 0 to 15 decimal places, user selectable

**Engineering Units:** User selectable units or custom units Time, Distance, Volume, Pressure, Weight, Temperature, Current, Voltage, Percent, Amps, Volts, Counts, Logic, and Custom, Any unit/unit of time or other units

**Feet & Inches Units:** Data entry format: Decimal (e.g. 50.58 feet) Display format: 50' 6.96"

**Units Conversion:** Units' conversion is supported for channels, totals, timers, and any function using those parameters. Channel scaling must be in the intended base units (e.g. Gallons/min)

**Display Update Rate:** User selectable: 0.1 to 0.5 sec (10 updates/sec to 2 updates/sec)

**Programming Method:** Front panel buttons, external buttons, or ConsoliDator+ Software

**Number of Alarms:** Up to 64 high or low, Logic AND & OR Automatic (non-latching) or latching On & Off time delays

Can be assigned to one or more relays.

*Note: Alarms are independent from relays.*

**Alarm Types:** Single Source: One input

Multi-Source: Two or more inputs

Interval: Enter time interval and On Time

Day & Time: Select day of the week & time

Alarm OR: Any active input alarm triggers the OR alarm

Alarm AND: All alarms must be active to trigger the AND alarm

**Alarm Ack & Reset:** Automatic only (Non-latching)

Automatic and manual

Manual only (Latching)

Manual with Ack only after alarm is cleared (Latching with Clear)

**Alarm Indication:** 1. Bargraph, panel, and text can be set up to change color on alarm

2. Enable internal buzzer

3. Assign external relay to drive a horn

**Internal Buzzer:** 60 dBA @ 24 inches (61 cm) Enable/disable in System – General menu. Associated with alarm Horn setting

**External Horn (Sold separately):** Assign any relay to the Horn function to activate an external horn when alarm condition is detected.

**Live Channel Calibration:** Live calibration of channels is independent of the input calibration used for scaling.

**Input & Output Cards:** Max Number of I/O Cards: 7

Analog Inputs: 4/card, Pulse Inputs: 4/card, Analog Outputs: 5/card, Relays: 5/card

**Number of Screens:** Up to 20 screens with 1 to 8 PVs or items per screen. Enable or disable screen title, channel #, and bargraph Automatic or manual scanning Scan time: 1 to >1000 sec, independent for each screen. F1-F4 keys are assigned per screen

**Function Keys:** User programmable (See defaults below)

F1 = Previous ← F2 = Next → F3 = Scan/Stop F4 = Ack

**Number of Channels:** Up to 99 channels

Input Source: 4-20 mA, Pulse, Digital, Modbus, another Channel, Total, Timer, Alarm, Date & Time, mA Output, Relay Output, Digital Output, or Modbus Output

**Channel Functions:** There is an extensive number of functions that can be applied to the inputs

**Password:** Programmable password restricts modification of programmed settings. View and Setup menus are password protected, function keys and digital inputs are not protected.

**Simulation Mode:** Inputs, channels, totals, timers, and alarms can be simulated from the View menu or from a function key. Simulation mode is not saved on power down. Alert! message is provided for simulated items.

**Manual Control:** Analog outputs and relays can be controlled manually from the View menu or from a function key.

Manual control mode is not saved on power down. Alert! message is provided for outputs in manual control.

*Note: If it is necessary to turn relays off and maintain the condition through power cycle, configure the relays to Always Off.*

**Non-Volatile Memory:** Settings stored for a minimum of 10 years.

**Power (User Selectable Based on Wiring):** Three-terminal connector (L, N, GND), AC: 80-264 VAC, 47 to 63 Hz, 60 W max DC: 113-370 VDC, 60 W max (L, N)

Two-terminal connector (G, 24V) DC: 24 VDC  $\pm 10\%$ , 60 W max

**Backup Power Supply:** If AC and DC power are connected, the 24 VDC can be used as backup power in case of AC power failure.

*Note: DC supply must be 24 V or less; otherwise the system runs on DC power.*

**Fuse:** Unit is protected internally with auto-resettable fuse.

AC: 1.25 A max, DC: 3.7 A max

**External Fuse:** Recommended external fuse slow-blow 120 VAC: 2.0 A, 240 VAC: 1.0 A, 24 VDC: 4 A

**Isolation & Grounding:** 1500 V Analog inputs/outputs-to-power line, 500 V Analog input-to-input, input-to-output, analog output-to-output

All analog inputs and analog outputs are isolated from each other.

*Note: DC Power is not isolated. DC- is connected to Earth Ground. Digital I/O, USB, and Ethernet are grounded.*

**Environmental:** Operating temperature range: -40 to 60°C (-40 to 140°F)

Storage temperature range: -40 to 60°C (-40 to 140°F)

Relative humidity: 0 to 90% non-condensing

*\*All functions operate down to -40°C (-40°F). If the LCD response is slower, increase the display refresh setting.*

**Internal Fan:** Automatic temperature-controlled fan turns on if the inside temperature reaches 50°C and increases the speed as the temperature rises to 60°C.

**Internal Heater:** Automatic temperature-controlled heater located behind the LCD turns on at 0°C, delivering the minimum power. If the temperature drops below -10°C, the heater delivers its maximum power.

**Connections:** Removable screw terminal blocks

Inputs/Outputs: 12 to 24 AWG wire, Digital I/O: 16 to 30 AWG,

RS-485: 12 to 24 AWG wire RJ45 Ethernet connection,

USB ports: Micro-USB used for programming, cable included.

USB Host: Type A, used with Data Logger Add-On feature.

**Tightening Torque:** Screw terminal connectors: 5 lb-in (0.56 Nm)

Digital I/O terminals: 2.5 lb-in (0.28 Nm)

**Enclosure:** Enclosure Body: Thermoplastic Polyester,

Color: Gray,

Display Window: Clear Polycarbonate, GE LEXAN HP12W

Front Panel Keys: Silicone rubber

**Mounting:** Panel-mounting frame and twelve screws (provided)

Cutout: 10.0" x 10.0"  $\pm 0.05$ " (254 mm x 254 mm  $\pm 1.3$  mm) (H x W x D)

Panel thickness: 0.07" – 0.35" (1.8 mm – 8.9 mm)

Clearance behind panel: 6" (152 mm)

**Overall Dimensions:** 10.85" x 10.85" x 4.87"

(276 mm x 276 mm x 124 mm) (H x W x D)

**Weight:** Ex: PD9000-XY-4PI-8AI-10AO-10RY

7.4 lb (3.4 kg) approx.

**Warranty:** 3 years parts and labor. See Warranty Information and Terms & Conditions on [www.predig.com](http://www.predig.com) for complete details.

## Totalizer

**Number of Totalizers:** Up to 32 totalizers, 15 digits with comma separator

**Totalizer Inputs:** Calculates total based on selected rate channel, pulse input, digital input, or triggered event for non-rate channels. Total is stored in non-volatile memory if power is lost.

**Maximum Total:** 18 digits, 999,999,999,999,999,999

**Rate Channel Input:** 4-20 mA input, Pulse input, Modbus input

**Rate & Total Decimal Point:** Independent and user selectable from 0 to 15 places

**Totalizer Reset:** Via front panel keys or digital inputs

**Non-Resettable Total:** Total may be set up to be non-resettable to prevent unintentional reset. This can be changed in the Setup Totals menu.

**Total Units Conversion :** Input: Rate channel

Total units may be different than rate units. Use the custom units to convert to any unit (e.g. Gallons to MGal: Factor = 0.000001)

**Pulse Input K-Factor:** K-Factor = pulses/units of measure. Calculates total directly from pulse input, Modbus input, channel, total, or Modbus output. Create rate channel by entering K-Factor, units and time base in sec, min, hr, or day. Decimals: 0 to 15

**Count Down:** Total can be set up to count down from a predetermined value entered by the user.

**Preset Value:** Enter the preset value to count up or down. Reset total sets total to the preset value; to reset to zero uncheck the Preset box.

**Roll-Over:** Enter the value for total to roll-over to 0. Example: Roll-Over = 1,000,000

Total goes to 0 after 1 million

**Negative Total:** Allow total value to count below 0 for bi-directional flow based on rate channel

**Total Bargraph:** Bargraph can be scaled to represent the expected maximum total.

**Function Keys:** Screen Setup: Assign F1-F4 to Reset Total, Enter Total, Add To, or Remove From total

**Previous Total:** This is the total prior to the last reset. Multiple previous totals can be set up by selecting a previous total as the input to a new total. The date & time is captured with the previous total.

**Daily Total:** This is the total for the day, starting at midnight. Daily total can be the input for previous totals to keep a record of a few days. The date is captured with the previous total.

**Grand Total:** Uses another total as the input and it is set up as non-resettable

**Non-Rate Total:** This total takes the input from a non-rate channel, a trigger causes the total to increment or decrement based on the settings selected (e.g. Input from weight scale added when digital input is triggered).

## Real Time Clock

**Date Format:** Month, day, year (e.g. July 16, 2020)

**Time Format:** 24 hour; 00: Midnight hh:mm:ss

**Battery:** 3 V, P/N: CR2032 included

**Display Date & Time:** Displayed on the top line of Setup and View menus, including day of the week.

**Screens:** Date & Time can be added to any screen.

**Channels:** Date & Time can be the input to a channel.

Display Format: yyyy/mm/dd hh:mm:ss

## Channel & Math Functions

Scale Functions		
K-Factor		Converts number of pulses to volume or other units
Scale Factor		Apply multiplier to a channel
Scale Linear 2-Pt		Scale a channel
Scale Multi-Point*		Multi-point scaling of a channel
Scale Square Root		Apply square root to a channel – Differential Pressure from two channels
Scale Exponent		Apply exponent for weirs and flumes open channel flow calculation
Round Horizontal Tank		Calculate volume in round horizontal tank with flat ends
Units Conversion		Convert base units to custom units
Percent (Bargraph)		% bargraph of any: 4-20 mA input, channel, total, timer, or mA output
Text (Percent)		Text displayed based on the % input value

Math Functions		
Constant		Assign fixed value
Summation		Add two or more channels
Difference		Subtract any two channels
Abs Difference		Difference always positive
Absolute Value		Convert channel value to positive
Average		Find the average of channels
Weighted Average		Assign % weight to two or more channels
Multiply		Multiply two channels
Divide		Divide two channels
Exponent		Set the base and the exponent; both can be constants or variables
Logarithm		Set the base and the value; both can be constants or variables
Modulo		Set constants or variables for A mod B
Trigonometry		Sine, cosine, tangent, arc sine, arc cosine, arc tangent. Select the input and angle
% Efficiency		Calculate input to output efficiency $((A-B)/A)*100\%$

### IMPORTANT

**\*Scale multi-point:** there is no minimum input span requirement; it is up to the user to make sure the input values are correct.

# PD9000 Multivariable Controller

<b>Open Channel Flow Functions</b>	Parshall Flumes	$Q = K H^n$ Enter constant, head variable, exponent, and units
	V-Notch Weirs	$Q = K H^{2.5}$ Enter constant, head variable, and units
	Cipolletti Weirs	$Q = K L H^{1.5}$ Enter constant, crest length, head variable, and units
	Rectangular Weirs w/o Contractions	$Q = K L H^{1.5}$ Enter constant, crest length, head variable, and units
	Rectangular Weirs with Contractions	$Q = K (L - 0.2H) H^{1.5}$ Enter constant, crest length, head variable, and units

<b>Additional Functions</b>	<b>Compare</b>	
	Greatest	Greatest value in a group of channels
	Least	Smallest value in a group of channels
	Middle of 3	Outputs the middle value of three inputs
	<b>Measure</b>	
	Tare	Calculate net value when Tare function is applied via function key
	Maximum	Maximum value reached by the process
	Minimum	Minimum value reached by the process
	Duration	Keep track of time a condition has been present (e.g. high alarm active)
	Rate of Change	Calculates how fast a process is changing /sec, /min, /hr, /day
	<b>Filter</b>	
	Window Average	Enter time to calculate the average
	IIR (First Order)	Infinite Impulse Response (slow)
	Cutoff	PV = 0 below cutoff Flip Side: 0 above (-)
	Limits	Sets PV upper & lower limits.
	Round	Round (to nearest) Floor (always down) Ceiling (always up) Less (toward zero) More (away from zero)
	Hysteresis	Resists a directional change using a time delay, filters change in the trending direction
	Delay	Enter the number of seconds to delay the output
	Pulse Filter	Use to filter discrete inputs, set minimum and maximum on/off time in seconds

<b>Additional Functions Continued</b>	<b>Control</b>	
	Sampler	Trigger relay sample and select sampling time (e.g. Turn relay on for 30 sec every time total increases by 1,000 Gallons)
	On-Off Control	Set on & off control based on PV
	On-Off Control with Random Varying On/Off Points	Select Randomizer, enter on/off points +/- random variation
	Select A or B	Switch between 2 inputs
	Select 1,2,3...	Select 1 from 3 or more inputs, it works as a selector switch.
	Capture	Set a trigger event to capture a value in real time
	Schedule	Daily or weekly event The available actions depend on configuration of inputs and outputs
	<b>Relays</b>	
	Cycle Count	Number of relay cycles since reset
	Runtime	Relay runtime (ON) hh:mm:ss
	<b>Modbus</b>	
	Time Since Read	Time since a Modbus client device read a register
	Time Since Write	Time since a Modbus client wrote to a register

## List of Engineering Units

**Time:** seconds, minutes, hours, days & /sec, /min, /hr, /day

**Distance:** (Height): cm, m, Inch, Feet, Ft-In, Yard, km, miles, custom

**Volume:** Gallons, GAL, L, IGAL, M3, BBL, BUSH, cuYD, cuFt, culn, LiBBL, BBBL, HECtL, quarts, pints, fl oz, mL, DT, M/T, custom

**Pressure:** psi, Pa, bar, hPa, kPa, MPa, GPa, inH2O, cmH2O, inHg, mmHg, atm, kg/cm2, kg/m2, mbar, Mbar, Torr, mTorr, custom

**Weight:** grams, Oz, Lb, lb, g, kg, ounces, tons, tonnes, custom

**Temperature:** C, F, K, Ra

**Percent:** %, PCT, Percent, custom

**Amps:** mA, Amps, custom

**Volts:** V, mV, Volts, custom

**Counts:** Pulses, Cycles, Counts, custom

**Logic:** ON, OFF, OPEN, CLOSED, YES, NO, START, RUNNING, STOP, STOPPED, PUMP ON, PUMP OFF, OK, OKAY, ERROR, WARNING, custom

**Custom:** Enter unit's name, type, base unit, and factor.



## 4-20 mA Analog Inputs

**Number of Inputs:** (4) Analog inputs/card  
(28) Analog inputs max, no other I/O

**Typical Input:** 4-20 mA

**Input Range:** 0-24 mA

**Accuracy:**  $\pm 0.03\%$  of full scale  $\pm 1$  count

**4-20 mA Display Value:** Up to six full digits recommended  
 $\pm 999,999$

More digits can be used, but the stability will be affected. Increase the filter value and lower the display update rate or use rounding to get a more stable reading.

**Transmitter Power Supply:** Isolated 24 VDC @ 200 mA/input  
Max current: 1,600 mA (All inputs), (8) Analog Input @ 200 mA max,  
(28) Analog Input @ 20 mA max  
Available on AC or DC powered units

**Temperature Drift:** Better than 20 ppm/ $^{\circ}$ C from  $-40$  to  $60^{\circ}$ C ambient

**Filter:** Window average: None, 0.5, 1, 2, 4, 8 sec

IIR (Infinite Impulse Response): 16, 32 sec

Glitch Filter: Discards a single sample caused by high frequency noise

**Filter Bypass:** 0 to 100 % of full scale

Filter is ignored, if the signal change is greater than bypass value

**Channel Input Scale Function:** Scale Linear 2-Point

Scale Multi-Point (2 to 50 points)\*

Scale Square Root

Scale Exponent (Open Channel Flow)

Scale Factor

Round Horizontal Tank (Volume)

Units Conversion (mA Input Reading)

Percent Bargraph

Text (Percent)

**Channel Input Live Calibration:** Each channel may be calibrated using live calibration signal from a sensor or a calibrator.

**Input Protection:** Each 4-20 mA input is protected by an auto-resettable fuse, 30 VDC max. The fuse resets automatically after the fault condition is removed.

**Input Impedance:** 125  $\Omega$  typical, Including auto-resettable fuse

**Hart Transparency:** The controller does not interfere with existing HART communications; it displays the 4-20 mA primary variable and it allows the HART communications to pass through without interruption. The controller is not affected if a HART communicator is connected to the loop. The controller does not display secondary HART variables.

**Isolation:** 1500 V: Input-to-power line

500 V: Input-to-input, input-to-output

All analog inputs and analog outputs are isolated from each other.

**Normal Mode Rejection:** 100 dB at 50/60 Hz

**Common Mode Rejection:** 90 dB at 50/60 Hz

### IMPORTANT

*\*Scale multi-point: there is no minimum input span requirement; it is up to the user to make sure the input values are correct.*

## Pulse Inputs

**Number of Inputs:** (4) Pulse inputs/card,  
(28) Pulse inputs max, no other I/O

**Input Type:** Active Square Wave, NPN, PNP, Reed Switch, Coil (Magnetic Pickup)

Normal threshold: 1.2 V (0.8 to 3.0 V)

High threshold: 2.5 V (2.0 V to 6.0 V)

Coil threshold: 20 mV (Low) or 100 mV (High)

**Signal Level:** Active Square Wave: 0 to 30 V max

Typical: 0 to 5 V

Coil: 20 mVp-p to 30 Vp-p (Magnetic Pickup)

**Input Impedance:** Active, NPN, Reed: 10 k $\Omega$  pull-up to 5 V  
PNP: 10 k $\Omega$  pull-down to (S-)

Coil:  $>2$  k $\Omega$  (20 mV sensitivity),  $>10$  k $\Omega$  (100 mV sensitivity)

**Isolation:** Pulse inputs are not isolated, (S-) terminal is connected to system GND

**Input Protection:**  $\pm 36$  V, non-isolated

**Frequency Response & Signal Level:**

Active Square Wave 5 V: 0 to 100 kHz

Coil (Magnetic Pickup): 0 to 50 kHz

Frequency – Signal level (Coil: 20 mV)

20 mVp-p – 100 Hz

100 mVp-p – 10 kHz

Frequency – Signal level (Coil: 100 mV)

100 mVp-p – 90 Hz

500 mVp-p – 5 kHz

20 Vp-p – 50 kHz

**Minimum Frequency:** 250  $\mu$ Hz with High Gate = 4,000 sec

**Low Gate:** 1 to 99 sec

**High Gate:** 2 to 4,000 sec (Must be higher than low gate)

**Low Speed:** 100 Hz maximum, Used for contact debouncing

**Pulse Counter:** 8,388,607 maximum, used for troubleshooting purposes only

**Accuracy:**  $\pm 1$  count for K-Factor  $> 1$  or 30 ppm

**K-Factor:** Programmable pulses/unit of measure with up to 15 decimal resolution

**Scale Pulse Input:** Scale Linear 2-Point, Scale Multi-Point

Scaling: 2 to 50 points, Scale Factor, Units Conversion

**Live Calibration:** Pulse input channel can be calibrated using live calibration signal from a sensor.

## Modbus Inputs - Server

**Availability:** Standard feature

**Number of Inputs:** 199 Modbus RTU or ASCII

**Scale Modbus Input:** Modbus input can be used as the input for creating channels and totals, the same way the 4-20 mA inputs are used.

**Data Type:** Bit-Logic

Signed/Unsigned: 16 (Short), 32 (Long), 64 (Long-Long),

Float 32, Float 64 (Double)

**Decimal Point:** User selectable

**Comm Break & Timeout:** Specify what value to hold when a communication break occurs and how long to wait for new data before reporting a break condition.

**Input Action:** Specify what should happen when new data is written to the input register (e.g. add value to total).

## Digital Inputs & Outputs

**Digital Inputs:** 5 Inputs, non-isolated, 30 VDC max  
Standard feature on all ConsoliDator+ models

Low: 0 to 1.2 V

High: 2.8 to 30.0 V

Internal pull-up: 5 k $\Omega$  to 5 V

Max pulse frequency: 1 kHz @ 5 Vp-p

+5 V terminal: Internal pull-up 100  $\Omega$

*Note: Pulse inputs may be used as digital inputs.*

**Digital Input Types:** Normally open switch: External excitation not required (Current: 1 mA)

Open collector: 4.1 V open circuit voltage

Logic level: 0 to 30 V

**Assignment & Operation:** Active Low or Active High

Functions: Remote front panel button, total functions, timer control, alarm functions, screen navigation, horn functions, reset relay information. Digital inputs can be used as input source for channels, totals, and alarms.

**Digital Outputs:** 4 Outputs

Standard feature on all ConsoliDator+ models

Low: 0 V (no load), 1.5 V max @ 10 mA sink (External pull-up)

High: 5.0 V (no load), 3.5 V @ 10 mA load

Maximum current: 30 mA

Output impedance: 100  $\Omega$

Output protection: 150 mA auto-resettable fuse

Max frequency: 5 Hz

**Digital Output Assignment:** Digital outputs require logic units as the input. Input sources: Digital input, Modbus input, channel, alarm, horn, always on, or always off

**Input/Output Protection:**  $\pm 36$  V, non-isolated

## Relays

**Number of Relays:** (5) Relays/card

(30) Relays max with (4) analog or (4) pulse inputs, no other I/O

**Rating:** SPDT (Form C)

Resistive load: Rated 10 A @ 120/240 VAC or 8 A @ 30 VDC

Inductive load: NO contacts: 1/3 HP, 120 VAC; 30,000 cycles

NC contacts: 1/8 HP, 120 VAC; 50,000 cycles

Minimum load: 100 mA @ 5 VDC

**Maximum Current per Relay & Number of Relays:** 10 relays @ 10 A, 11+ relays @ 5 A

Limited due to heat dissipation inside the enclosure.

**Isolation:** 1500 VAC, 50/60 Hz for 1 min between coil and contacts

**Deadband:** 0-100% of full scale, user selectable

**Electrical Noise Suppression:** TVS diodes & snubbers on all contacts. Recommended additional external snubber:

0.01  $\mu$ F/470  $\Omega$ , 250 VAC (Order: PDX6901)

**Assignment & Operation:** Any relay may be assigned to any alarm, channel, total, timer, digital input, Modbus input, pump alternation, horn, always on, or always off. Multiple relays can be assigned to the same alarm or channel. All relays are programmed independently.

High & Low Alarm: Defined by set and reset points in the Alarm menu

High or Low Alarm: Assign relay to any alarm or channel for on/off relay control. *Note: Automatic reset only for channel*

Multi-Source High or Low Alarm: Assign relay to multi-source alarm to indicate common high or low condition.

Pulse Action: Set any relay for pulsing on/off timed relay control.

Programmable pulse width (on/off time) and on/off delay.

Sampling: Relay must be assigned to channel setup for Sampler function with user-defined total increment and sampling time.

Pump Alternation: Any relay can be set up to alternate with any relay in the group. Multiple alternation groups can be set up.

**Acknowledge:** Front panel **Ack** key or digital input acknowledges individual or all alarms; relays associated with acknowledged alarm are turned off.

**Alarm Relay:** Assign any relay to be driven by any alarm; acknowledging the alarm turns off the relay (non-fail-safe mode).

**Time Delay:** Programmable on/off delays, 0.0 to 999.9 sec Independent for each relay.

**Auto Initialization:** When power is applied to the controller, relays will reflect the state of the input to the controller.

**Fail-Safe Operation:** The relay coil is energized when the process variable is within safe limits and the relay coil is de-energized when the alarm condition exists.

## 4-20 mA Transmitter Outputs

**Number of Analog Outputs:** (5) Analog outputs/card,

(35) Analog outputs max with no other I/O cards (Seven I/O slots)

**Output Range:** 4.00 to 20.00 mA, nominal

**Calibration:** Factory calibrated for 4-20 mA

**Scaling Range:** Any process range

Reverse scaling allowed

**Assignment & Operation:** Assign to any analog or pulse input, digital input, Modbus input, channel, total, timer, alarm, or fixed value (none).

*Note: Multiple 4-20 mA outputs can be assigned to the same input.*

**Accuracy:**  $\pm 0.03\%$  F.S.  $\pm 0.005$  mA

**Temperature Drift:** 20 ppm/ $^{\circ}$ C from  $-40$  to  $60^{\circ}$ C ambient.

(Output & Input drifts are separate)

**Output Loop Power:** Powered by controller or externally by 12 to 32 VDC

**Output Loop Resistance:** Powered by controller: 10 to 600  $\Omega$

External 12 VDC: 10 to 200  $\Omega$

External 24 VDC: 10 to 600  $\Omega$

External 32 VDC: 10 to 1000  $\Omega$

**Isolation:** 1500 V: Output-to-power line

500 V: Output-to-output, output-to-input

All analog inputs and analog outputs are isolated from each other.

## Timers

**Number of Timers:** Up to 32

**Time Format:** hh:mm:ss with 0 decimals selected  
Seconds with 1 or more decimals

**Automatic Actions:** Power Up: Timer action on power up

Error: Action when an error is detected

Reset: Event causes the timer to reset

Start: Event triggers the timer to start

Stop: Event causes the timer to stop

**Start / Stop Reset:** The function keys and digital inputs can be used to start, stop, and reset the timers, regardless of the automatic actions selected.

**Assignment & Operation:** Timers can be triggered, stop, and reset, by rising or falling signals from 4 20 mA input, pulse, digital, Modbus input, channel, total, other timers, alarm, mA output, relay, or Modbus output.

**Count Down Timer:** Select count down and enter starting time

**Timer Alarm:** Timer can be used to trigger alarms

**Bargraph:** Select bargraph during setup and scale the bargraph for 0 – 100% target time

**Timer Control:** Access timer control via the *View Timer* menu or assign a function key to timer control in the *Screens* menu

**Timer & Relay:** Timer can be assigned to drive relays based on selected set and reset points

## Modbus Outputs - Server

**Availability:** Standard feature

**Data Type:** Bit-Logic

Signed/Unsigned: 16 (Short), 32 (Long), 64 (Long-Long)

Float 32, Float 64 (Double)

**Register Numbers:** The register numbers are automatically generated based on the Modbus output number and the output's data type.

Bit – Logic: 04101 – 04199

Signed/Unsigned 16: 44101 – 44199

Signed/Unsigned 32: 44201 – 44398

Signed/Unsigned 64: 45001 – 45396

Float 32: 44401 - 44598

Float 64: 44601 - 44996

**Engineering Units:** Select the engineering units for the process variable assigned to the output.

**Decimal Point:** User selectable. For short and long integers this is a multiplier applied to the input value, but it is not displayed on the server's screen. The Modbus client uses this setting to read the correct value from the server.

Example: Ch 1 value = 4,379.26

MB Output Data Type: Signed 32

Decimals = 0 → Output = 4,379

Decimals = 3 → Output = 4,379,260

**Output Action:** Specify what should happen when the output register is read by the client (e.g. Start timer 1).

## Modbus Serial Communications

**Compatibility:** RS-485 (EIA-485)

**Protocol:** Modbus RTU or Modbus ASCII

Modbus Enron is supported by the Client and the Spoofer modes.

**Device Address:** 1 to 247 (Server)

**Transmit Delay:** 0 to 99 ms

**Receive Timeout:** 1 to 9 seconds

**Baud Rate:** 1,200 to 115,200 bps

**Data:** 8 bit (1 start bit, 1 stop bit)

**Parity:** Even, Odd, None with 1 stop bit, or None with 2 stop bits

**Outputs Inputs:** 199 for all modes

**Modbus Outputs:** 99 for all modes. The outputs can be grouped together to be sent as blocks of registers. These Modbus outputs are in addition to the outputs listed in the Modbus Register Tables, see the [PD9000 manual](#).

**Communication Break:** Reports a break condition after the response timeout has elapsed. The break condition can be: Zero, a default value, or the text Break.

The Client goes into break condition after the server device fails to respond and the timeout has elapsed.

The Snooper and Server modes go into break condition after no new data is received within the response timeout window.

Alarms can be programmed to go on, off, or stay as is when a break condition is detected. The analog outputs can be set up to generate a fixed mA current when a break condition is detected.

## Modbus Client, Snooper & Spoofer

**Add-On Features PDK9000-M1:** Client, Snooper & Spoofer

The Modbus Client is an option in the ConsoliDator+. It can be purchased at the time the order is placed or it can be purchased and enabled at any time. The Modbus Snooper & Spoofer features are part of the Client Add-On feature.

**Modes:** Client: Requests data from servers and writes data to servers.

Snooper: Listens to the RS-485 network communications and reads the selected registers.

Spooper: A channel is configured to pretend being a device that has been removed from the network. The device ID and register number is used.

## Client & Snooper Settings

**Availability:** Order Add-On Feature model PDK9000-M1 at any time.

**Number of Output PVs:** 99 process variables can be written by the Client mode to Modbus servers. Modbus server inputs and outputs are available over the Ethernet port, in Client mode also.

**Server ID:** Enter the server ID or address containing the process variables to be read or written by the Client or read by the Snooper.

**Function Code:** Select which Modbus function code to use for reading the server device or for writing to a server by the ConsoliDator+ Client.

**Register Address:** 0-65,533 (Base 0)

Reg. No. 30001-39999, 40001-49999

Reg. No. 300001-365534 or 400001-465534

Specifies which register(s) to read from the server device.

**Data Type:** Select the data format used by the server device.

Bit – Logic (Coil)

Signed/Unsigned: 16 (Short, 2 byte)

32 (Long, 4 byte)

64 (Long Long, 8 byte)

Float 32 (4 byte), Float 64 (Double, 8 byte)

**Byte Order:** ABCD, CDAB, BADC, or DCBA (big-endian, swapped, or little-endian)

**Client Poll Time:** 1.0 to 999.9 sec. Time between read commands

**Server Response Timeout:** 99:59:59 hrs.: Time allowed for the server to respond before the Modbus client generates a communication break condition. The timeout should be greater than the poll time.

Server/Snooper mode: Time the Modbus input will wait for new data before going into a break condition.

If the timeout is disabled, the last value will remain until a new value is received.

## Spoofers Settings

**Availability:** Order Add-On Feature model PDK9000-M1 at any time.

**Number of Output PVs:** 99 process variables can be replaced by the ConsoliDator+ Spoofer feature.

**Number of Input PVs:** 199 process variables can be written by a client to the Spoofer inputs replacing other Modbus servers.

**Server ID:** Enter the server ID or address being replaced by the ConsoliDator+ Spoofer.

**Function Code:** Select the Modbus function code used by the server device.

**Register Address:** Enter the address 0-65,533 (Base 0) for the process variable of the replaced server.

**Data Type:** Select the data format used by the server.

**Byte Order:** Select the byte order ABCD, CDAB, BADC, or DCBA (big-endian, swapped, or little-endian)

**Engineering Units:** Select the engineering units for the process variable.

**Decimals:** Enter the number of decimals required

**Output Action:** Select an action to be performed by the controller, when the Spoofer output is read by a Modbus client or leave as None.

## Data Logger – USB Drive

**USB Data Logger Add On Feature PDK9000-D1:** The Data Logger is an option in the ConsoliDator+. It can be purchased at the time the order is placed or it can be purchased and enabled at any time. The Data Logger feature is available on ConsoliDator+ units with a firmware version 2.2 or greater.

**Storage Device:** External USB flash drive

Format: FAT32 (32 GB maximum)

Recommended drive: SanDisk 32GB maximum.

**Number of Data Logs:** 8, maximum

**Number of Variables / Log:** 12, maximum

**Number of Log Variables:** 96 variables, maximum

(8 logs x 12 variables / log)

**Number of Log Records:** The number of records depends on the flash drive size.

Examples for 32 GB:

- 1) 4 logs with 8 variables each  
1 min rate: ~160,000,000 records  
Log time: 60 years
- 2) 8 logs with 12 variables each  
1 min rate: ~70,000,000 records  
Log time: 16 years

**Log File Type:** csv (comma separated value)

**Maximum Log File Size:** 100 MB

A new file is automatically created when the log file exceeds 100 MB.

**Stop when Full:** This should be selected if the oldest logged data is more important than logging new data.

If *Stop when Full* is not selected, the oldest block of data will be deleted to make room for new data.

**Remove Device:** Use the Remove Device button, in the *System – USB Drive*, to safely remove the USB drive and prevent data corruption.

**Start / Stop:** Selecting this feature enables the *Start / Stop* function key in the *View – Data Logs* menu. The *Start / Stop* function can be activated using the digital inputs, F1-F4 function keys in the *Setup – Screens* menu, Channel control schedule, Modbus inputs, and Modbus outputs.

**Log Enable Switch:** The *Enable Switch* setting can be used to control the log process using digital inputs, Modbus inputs, Channel control, alarms, or relay outputs. Logs are recorded only if the *Enable Switch* input is in the active (on) condition.

**Log Trigger:** The *Log Trigger* setting is used to log data on a specific event; a log can be triggered using digital inputs, Modbus inputs, Channel control, alarms, relays.

**Manual Log:** The user can record a log entry at any time by using the F4 key in the *View – Logs* menu or by assigning a function key in the *Setup – Screens* menu.

**Log Interval:** 00:00:01 to 23:59:59 hrs:min:sec

## How to Enable Add-On Features

To enable the Data Logger features, see Add-On Features in the PD9000 instruction manual.

### IMPORTANT

The USB Data Logger functions are available only if the Add-On feature has been enabled in the *System – General Settings*, see Add-On Features in the PD9000 instruction manual.

# PD9000 Multivariable Controller

## Sample Data Log File

Device Tag: Multivariable Controller									
Log Name: Tank Farm Log									
Date	Time	T1. Tank 1	T1. Units	T2. Tank 2	T2. Units	T3. Tank 3	T3. Units	T4. Tank 4	T4. Units
4/8/2021	7:41:07	109690	Gallons	99690	Gallons	89690	Gallons	79690	Gallons
4/8/2021	7:41:10	109691	Gallons	99691	Gallons	89691	Gallons	79691	Gallons
4/8/2021	7:41:11	109692	Gallons	99692	Gallons	89692	Gallons	79692	Gallons
4/8/2021	7:41:12	109693	Gallons	99693	Gallons	89693	Gallons	79693	Gallons
4/8/2021	7:41:13	109694	Gallons	99694	Gallons	89694	Gallons	79694	Gallons
4/8/2021	7:41:14	109695	Gallons	99695	Gallons	89695	Gallons	79695	Gallons
4/8/2021	7:41:15	109696	Gallons	99696	Gallons	89696	Gallons	79696	Gallons
4/8/2021	7:41:16	109697	Gallons	99697	Gallons	89697	Gallons	79697	Gallons
4/8/2021	7:41:17	109698	Gallons	99698	Gallons	89698	Gallons	79698	Gallons
4/8/2021	7:41:18	109699	Gallons	99699	Gallons	89699	Gallons	79699	Gallons
4/8/2021	7:41:19	109700	Gallons	99700	Gallons	89700	Gallons	79700	Gallons
4/8/2021	7:41:20	109701	Gallons	99701	Gallons	89701	Gallons	79701	Gallons
4/8/2021	7:41:21	109702	Gallons	99702	Gallons	89702	Gallons	79702	Gallons
4/8/2021	7:41:22	109703	Gallons	99703	Gallons	89703	Gallons	79703	Gallons
4/8/2021	7:41:23	109704	Gallons	99704	Gallons	89704	Gallons	79704	Gallons
4/8/2021	7:41:24	109705	Gallons	99705	Gallons	89705	Gallons	79705	Gallons
4/8/2021	7:41:25	109706	Gallons	99706	Gallons	89706	Gallons	79706	Gallons
4/8/2021	7:41:26	109707	Gallons	99707	Gallons	89707	Gallons	79707	Gallons
4/8/2021	7:41:27	109708	Gallons	99708	Gallons	89708	Gallons	79708	Gallons
4/8/2021	7:41:28	109709	Gallons	99709	Gallons	89709	Gallons	79709	Gallons
4/8/2021	7:41:29	109710	Gallons	99710	Gallons	89710	Gallons	79710	Gallons
4/8/2021	7:41:30	109711	Gallons	99711	Gallons	89711	Gallons	79711	Gallons
4/8/2021	7:41:31	109712	Gallons	99712	Gallons	89712	Gallons	79712	Gallons
4/8/2021	7:41:32	109713	Gallons	99713	Gallons	89713	Gallons	79713	Gallons
4/8/2021	7:41:33	109714	Gallons	99714	Gallons	89714	Gallons	79714	Gallons

## Ethernet Communications

**Device:** Lantronix Xport-05  
**Protocol:** Modbus TCP/IP (Default)  
 Modbus UDP/IP  
 Modbus RTU Over TCP/IP  
 Modbus RTU Over UDP/IP  
**Port Settings (Do Not Change):**  
 Protocol: RS-232  
 Baud Rate: 9600  
 Data Bits: 8  
 Flow Control: None  
 Parity: None, Stop Bits: 1  
**Network Stack:** IPv4  
**Ethernet Mac/Phy:** 10/100 Mbps  
**Additional Specifications:** Refer to the Lantronix Webpage <https://www.lantronix.com/products/xport>  
**Ethernet Port Configuration:** Use the System menu for basic Ethernet configuration or download the Lantronix DeviceInstaller software to fully configure the Ethernet port.  
<https://www.lantronix.com/products/xport>  
 See the [PD9000 manual](#) for instructions.

## ConsoliDator+ Software

**System Requirements:** Windows® 7, 10  
**Compatibility:** The software and firmware versions must be matched.

### CAUTION

Do not write configuration files created using older versions of the firmware and software to controllers with Add-On features enabled (Ver. 2.1 & up). This can create undesirable results, especially with the function keys F1-F4.

**Connection:** Standard USB A to Micro-USB type B (cable included).  
**Configuration:** Configure inputs and outputs, channels, totals, timers, alarms, etc. Configure bargraph and panel colors for normal operation, and colors for alarm indication. Save controller settings file on PC for programming other controllers or to restore settings.

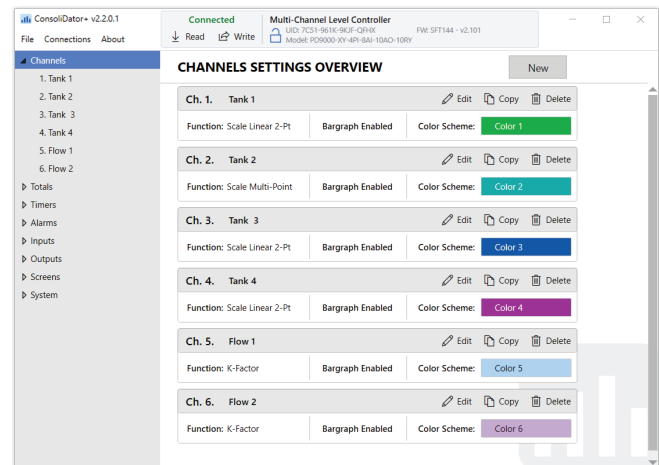



# PD9000 Multivariable Controller

## DIMENSIONS

### Overall Dimensions

Units: Inches (mm)

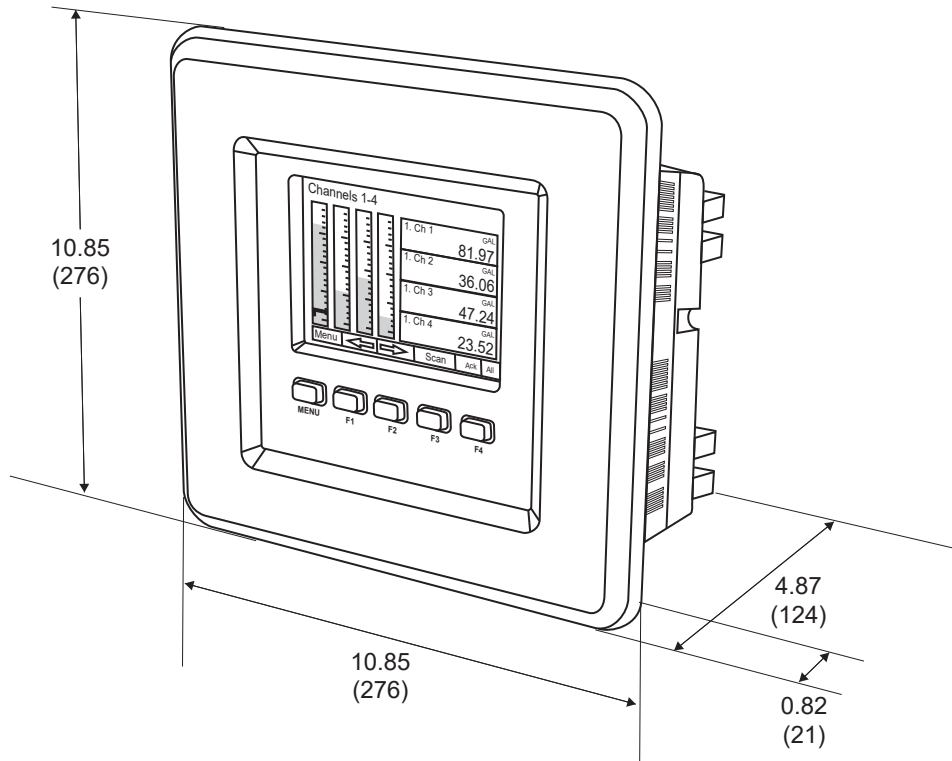

Panel Mount Controller



Download free 3-D CAD files of these instruments to simplify your drawings!

[predig.com/documentation-cad](http://predig.com/documentation-cad)



## Panel Mounting

- Prepare panel cutout per the dimensions provided
- Locate the panel mounting bracket and screws
- Inspect the controller to assure the gasket is securely in place
- Insert controller in the panel cutout, the latches on the top and bottom should hold it in place
- Insert the panel mounting bracket from the back of the panel, observe the orientation of the piece marked TOP
- Install the 12 screws provided

Units: Inches (mm)

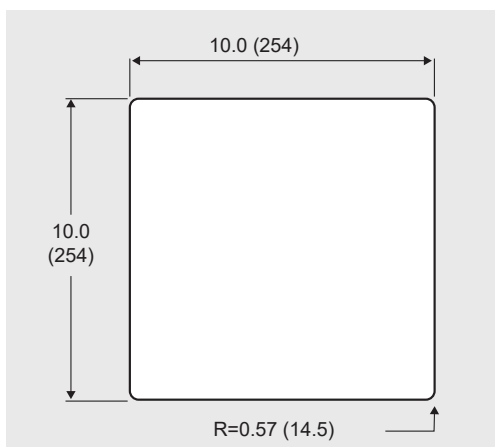

Panel Cutout Dimensions

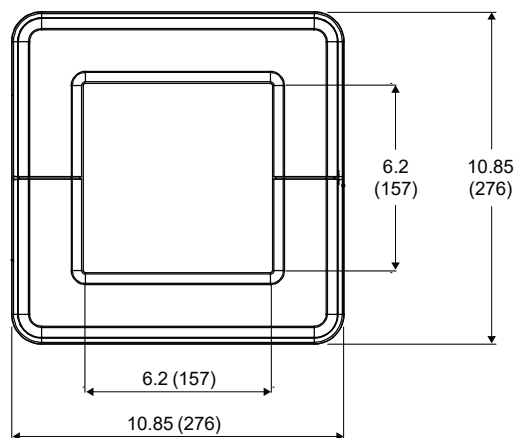

Front Panel Dimensions

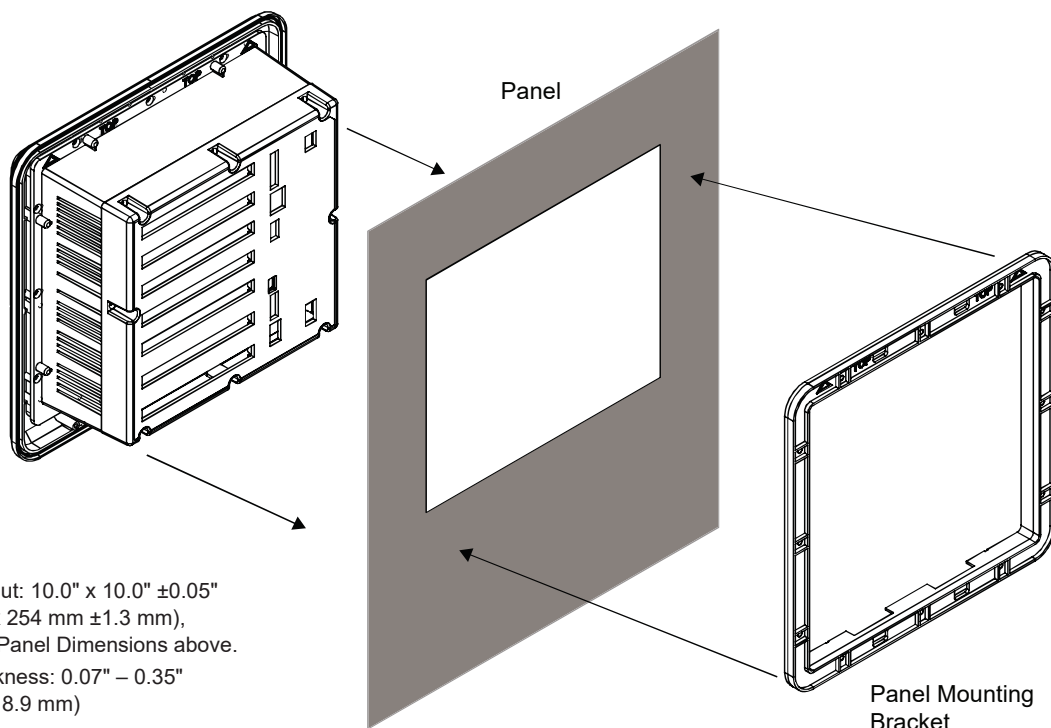

### Notes:

1. Panel cutout: 10.0" x 10.0"  $\pm 0.05$ " (254 mm x 254 mm  $\pm 1.3$  mm), see Front Panel Dimensions above.
2. Panel thickness: 0.07" – 0.35" (1.8 mm – 8.9 mm)
3. Clearance: Allow 6" (152 mm) behind panel

Panel Mount Installation

## ACCESSORIES

### PD9000-ENC ConsoliDator+ NEMA 4X Plastic and NEMA 4 Steel Enclosures

The PD9000-ENC enclosures provide a convenient way to mount the PD9000 ConsoliDator+ to walls and other vertical structures. The enclosures are available in painted steel and plastic and come pre-cut with one cutout to mount the PD9000. The enclosures are available in various sizes, with the larger enclosures capable of housing other pieces of equipment, such as the PDA1024-01 power supply.

**Note:** The enclosure and ConsoliDator+ are ordered and packaged separately.

#### Features

- House One ConsoliDator+ PD9000
- Cutout for One ConsoliDator+ Provided
- ConsoliDator+ Mounts in Cover
- ConsoliDator+ Mounts Inside PDA3939 Clear Cover
- Sub-Panels Available
- PDA6909 Pipe Mounting Kit Available
- Light / Horn & Button Available
- UL Listed Plastic Enclosures
- UL Listed, CSA Certified Steel Enclosures



**PDA1909**

Dimensions: 11.8" x 11.8" x 5.9"  
(300 mm x 300 mm x 150 mm)  
(H x W x D)



**PDA1939**

Dimensions: 17.7" x 13.8" x 7.9"  
(450 mm x 350 mm x 200 mm)  
(H x W x D)

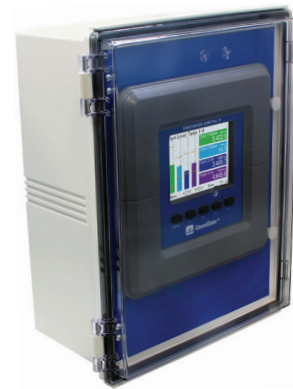

**PDA3939**

Dimensions: 17.7" x 13.8" x 7.9"  
(450 mm x 350 mm x 200 mm)  
(H x W x D)



**PDA2909**

Dimensions: 12.0" x 12.0" x 6.0"  
(305 mm x 305 mm x 152 mm)  
(H x W x D)



**PDA2919**

Dimensions: 14.0" x 12.0" x 8.0"  
(356 mm x 305 mm x 203 mm)  
(H x W x D)



**PDA2929**

Dimensions: 16.0" x 14.0" x 10.0"  
(406 mm x 355 mm x 254 mm)  
(H x W x D)



Download the PD9000-ENC datasheet for more information.



Download free 3-D CAD files of these enclosures to simplify your drawings!

[predig.com/documentation-cad](http://predig.com/documentation-cad)

## PDA9000SH Sun Hood



**PDA9000SH Installed on PD9000 ConsoliDator+ mounted in PDA2909 enclosure**  
(ConsoliDator+ and enclosure sold separately)

The PDA9000SH ConsoliDator+ Sun Hood provides shade for the ConsoliDator+ when it is mounted in direct sunlight. It is adhered to the ConsoliDator+ enclosure with industrial grade double-sided tape (provided).

## MOD-LH Light / Horn



**ConsoliDator+ Shown in a PDA2919 Enclosure with MOD-LHRB1 Red Light / Horn and Button**  
(ConsoliDator+ and enclosure sold separately. Assembly required.)

Precision Digital conveniently offers the MOD-LH which contains pre-drilled holes on a ConsoliDator+ enclosure for installation of the PDA-LH and PDA-BUTTON accessories.

The Light / Horn is available in three different light configurations and is designed to be mounted in any of the PD9000-ENC ConsoliDator+ enclosures.

The first option is a factory ordered Light / Horn with a color of either red, green, yellow, blue, or white. The second option is a Light / Horn the user determines the light color (red, green, yellow, blue or white) by connecting the appropriate wire. The third option is a Light / Horn with red, yellow, and green layers the user can turn on independently.

The light on the Light / Horn can be wired to flash (not available on PDA-LH5C) or stay steady on and the horn is rated at 85 dB.

The light and horn can be controlled independently of each other via separate relays on the ConsoliDator+; and since the controller's relays can be reset in a variety of ways, there are several ways the Light / Horn can operate. For instance, the horn can be programmed to silence at any time via the soft keys on the front of the ConsoliDator+, and reset the light automatically when the alarm clears.

When MOD-LH is ordered, the accompanying enclosure on the order comes with the holes pre-drilled for the Light / Horn and the Button, and the user performs the mounting and wiring. The ConsoliDator+ and enclosure are sold separately.

The PDA-LH Light / Horn and the PDA-BUTTON Button can also be ordered as separate items and the user performs all hole-drilling, mounting, and wiring as desired.

## ORDERING INFORMATION

General Purpose Panel Mount Models				
Model	Pulse Inputs	4-20 mA Inputs	4-20 mA Outputs	Relays
PD9000-GP (Modbus Monitor)	0	0	0	0
PD9000-GP-4AI	0	4	0	0
PD9000-GP-4AI-10RY	0	4	0	10
PD9000-GP-4AI-5AO-10RY	0	4	5	10
PD9000-GP-4AI-20RY	0	4	0	20
PD9000-GP-4AI-5AO-20RY	0	4	5	20
PD9000-GP-8AI	0	8	0	0
PD9000-GP-8AI-10RY	0	8	0	10
PD9000-GP-8AI-10AO-10RY	0	8	10	10
PD9000-GP-8AI-20RY	0	8	0	20
PD9000-GP-8AI-25RY	0	8	0	25
PD9000-GP-12AI	0	12	0	0
PD9000-GP-12AI-20RY	0	12	0	20
PD9000-GP-12AI-10AO-10RY	0	12	10	10
PD9000-GP-16AI	0	16	0	0
PD9000-GP-16AI-15RY	0	16	0	15
PD9000-GP-16AI-15AO	0	16	15	0
PD9000-GP-20AI	0	20	0	0
PD9000-GP-20AI-10RY	0	20	0	10
PD9000-GP-20AI-10AO	0	20	10	0
PD9000-GP-24AI	0	24	0	0
PD9000-GP-24AI-5RY	0	24	0	5
PD9000-GP-24AI-5AO	0	24	5	0
PD9000-GP-28AI	0	28	0	0
PD9000-GP-4PI	4	0	0	0
PD9000-GP-4PI-5AO	4	0	5	0
PD9000-GP-4PI-5AO-10RY	4	0	5	10
PD9000-GP-4PI-4AI-5AO	4	4	5	0
PD9000-GP-4PI-4AI-5AO-10RY	4	4	5	10
PD9000-GP-4PI-8AI-10AO-10RY	4	8	10	10
PD9000-GP-8PI	8	0	0	0
PD9000-GP-8PI-10AO	8	0	10	0
PD9000-GP-8PI-10AO-10RY	8	0	10	10
PD9000-GP-8PI-8AI-10AO-5RY	8	8	10	5

G = General Purpose  
P = Panel-Mount  
AI = Analog Input  
PI = Pulse Input

AO = Analog Output  
RY = Relay  
E = Ethernet (Add “-E” at the end of the model number)  
Example: PD9000-GP-4PI-8AI-10AO-10RY-E

Other models are available upon request.

# PD9000 Multivariable Controller

Add-On Features	
Model	Description
PDK9000-M1	Add-On Feature: ConsoliDator+ Modbus Client/Snooper/Spoofers (Ver. 2.1 & Up)
PDK9000-D1	Add-On Feature: ConsoliDator+ USB Data Logger (Ver. 2.2 & Up)

**Note:** Add-On features that are ordered with the ConsoliDator+ will be activated at the factory. Add-On features can be ordered for existing ConsoliDator+ units with a firmware version of 2.2 or greater, at any time. The user will receive a key they can enter into the ConsoliDator+ to unlock the Add-On feature. See the [PD9000 ConsoliDator+ manual](#) for instructions on how to enable the Add-On Features.

## ⚠ CAUTION

Do not write configuration files created with older versions of the firmware and software to controllers with Add On features enabled (Ver. 2.1 & up). This can create undesirable results, especially with the function keys F1-F4 and the digital inputs.

Input / Output Cards	
Model	Description
PDA9000-C4AI	(4) Isolated 4-20 mA Inputs Card for ConsoliDator+
PDA9000-C4PI	(4) Pulse Inputs Card for ConsoliDator+
PDA9000-C5AO	(5) Isolated 4-20 mA Outputs Card for ConsoliDator+
PDA9000-C5RY	(5) Relays Card for ConsoliDator+

Setup & Calibration Services	
Part Number	Description
PDN-CALCON+12	ConsoliDator+ Calibration and Certificate for up to 12 inputs and outputs
PDN-CALCON+24	ConsoliDator+ Calibration and Certificate for up to 24 inputs and outputs
PDN-CALCON+36	ConsoliDator+ Calibration and Certificate for up to 36 inputs and outputs
PDN-CALCON+12-DATA	ConsoliDator+ Calibration and Certificate with data for up to 12 inputs and outputs
PDN-CALCON+24-DATA	ConsoliDator+ Calibration and Certificate with data for up to 24 inputs and outputs
PDN-CALCON+36-DATA	ConsoliDator+ Calibration and Certificate with data for up to 36 inputs and outputs
PDN-CSETCON+	Custom Setup for ConsoliDator+

Enclosures	
Model	Description
PDA1909	NEMA 4X Plastic Enclosure for One ConsoliDator+ Dimensions: 11.8" x 11.8" x 5.9" (300 mm x 300 mm x 150 mm) (H x W x D)
PDA1939	NEMA 4X Plastic Enclosure for One ConsoliDator+ Dimensions: 17.7" x 13.8" x 7.9" (450 mm x 350 mm x 200 mm) (H x W x D)
PDA2909	NEMA 4 Steel Enclosure for One ConsoliDator+ Dimensions: 12.0" x 12.0" x 6.0" (305 mm x 305 mm x 152 mm) (H x W x D)
PDA2919	NEMA 4 Steel Enclosure for One ConsoliDator+ Dimensions: 14.0" x 12.0" x 8.0" (356 mm x 305 mm x 203 mm) (H x W x D)
PDA2929	NEMA 4 Steel Enclosure for One ConsoliDator+ Dimensions: 16.0" x 14.0" x 10.0" (406 mm x 355 mm x 254 mm) (H x W x D)
PDA3939	NEMA 4X Plastic Enclosure with Clear Cover for One ConsoliDator+ Dimensions: 17.7" x 13.8" x 7.9" (450 mm x 350 mm x 200 mm) (H x W x D)

## Accessories



### Light / Horn Accessories

Model	Description
MOD-LHRB1	Red Light / Horn and Button with Holes Drilled in Enclosure <sup>(1)</sup>
MOD-LHGB1	Green Light / Horn and Button with Holes Drilled in Enclosure <sup>(1)</sup>
MOD-LHYB1	Yellow Light / Horn and Button with Holes Drilled in Enclosure <sup>(1)</sup>
MOD-LHBB1	Blue Light / Horn and Button with Holes Drilled in Enclosure <sup>(1)</sup>
MOD-LHWB1	White Light / Horn and Button with Holes Drilled in Enclosure <sup>(1)</sup>
MOD-LH5CB1	Light / Horn with User Choice of Red, Green, Yellow, Blue or White Light, Button, and Holes Drilled in Enclosure <sup>(1)</sup>
MOD-LH3LCB1-RYG	Light / Horn with Red, Yellow, Green Light Layers, Button, and Holes Drilled in Enclosure <sup>(1)</sup>
PDA-LHR	Red Light / Horn
PDA-LHG	Green Light / Horn
PDA-LHY	Yellow Light / Horn
PDA-LHB	Blue Light / Horn
PDA-LHW	White Light / Horn
PDA-LH5C	Light / Horn with User Choice of Red, Green, Yellow, Blue or White Light
PDA-LH3LC-RYG	Light / Horn with Red, Yellow, Green Light Layers

**Note:**

1. This MOD supplies the Light / Horn and Button. The enclosure comes pre-drilled with holes for Light / Horn and Button and the user performs the installation and wiring. ConsoliDator+ and enclosure are sold separately. The Light / Horn hole is located on the top left corner of the enclosure and the Button is located on the bottom left side of the enclosure.

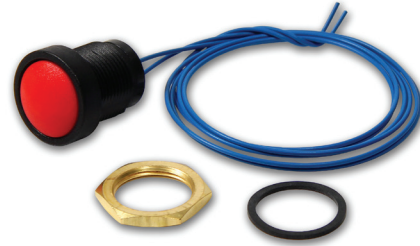

### PDA-BUTTON Momentary Pushbutton

Model	Description
PDA-BUTTON1B	NEMA 4X Black Button
PDA-BUTTON1G	NEMA 4X Green Button
PDA-BUTTON1R	NEMA 4X Red Button



### PDA9000SH Sun Hood

Model	Description
PDA9000SH	ConsoliDator+ Sun Hood



### PDA2360 Control Stations

Model	Description
PDA2360-E	Emergency Stop Button
PDA2361-A	1 Black Ack Button
PDA2361-Q	1 Black Silence Button



### PD9501 Multi-Function Calibrator

Model	Description
PD9501	Multi-Function Calibrator



# PD9000 Multivariable Controller



## Signal Splitter & Conditioner Accessories

Model	Description
PD659-1MA-1MA	Signal Isolator with One 4-20 mA Input and One 4-20 mA Output
PD659-1MA-2MA	Signal Splitter with One 4-20 mA Input and Two 4-20 mA Outputs
PD659-1V-1MA	Signal Conditioner with One 0-10 VDC Input and One 4-20 mA Output
PD659-1MA-1V	Signal Conditioner with One 4-20 mA Input and One 0-10 VDC Output



## PDA1024-01 Power Supply

Model	Description
PDA1024-01	24 VDC Power Supply for DIN Rail



## Split Core AC Current Transducer

Model	Description
PDA6420	Split Core AC Current Transducer. Input: 30/60/120 AAC; Output 4-20 mA

### Disclaimer

The information contained in this document is subject to change without notice. Precision Digital Corporation makes no representations or warranties with respect to the contents hereof, and specifically disclaims any implied warranties of merchantability or fitness for a particular purpose.

©2021 Precision Digital Corporation. All rights reserved.



## Panel Mount Buzzer and Light

Model	Description
PDA1000	Panel Mount Buzzer and Light



## Snubber 0.01µF/470Ω Flexible Leads

Model	Description
PDX6901	Snubber 0.01µF/470Ω Flexible Leads



## Low-Cost Signal Generator

Model	Description
PD9502	4-20 mA or 0-10 VDC, Low-Cost Signal Generator

Your Local Distributor is:



**WARNING**  
Cancer and Reproductive Harm - [www.P65Warnings.ca.gov](http://www.P65Warnings.ca.gov)

LDS9000\_F 08/21