



elcis
encoder

Via Rosa Luxembourg, 12/14 - 10093 Collegno (Torino) - Italy
Tel. +39 011 715577 - 011 715578 - Fax +39 011 712613
Corrispondenza: *Correspondence:* ELCIS ENCODER s.r.l.
P.O. Box 70 - 10093 Collegno (Torino) - Italy
www.elcis-encoder.com - info@elcis.com



LINEE PRODOTTI **PRODUCT LINES**
SENSORI MODULARI,
IN KIT E LOW-COST
MODULAR, KIT AND
LOW-COST SENSORS



SENSORI DI ELEVATA
QUALITÀ E CUSTOM
HIGH QUALITY AND
CUSTOM SENSORS

DIGITAL BIDIRECTIONAL COUNTER WITH TWO THRESHOLDS TYPE LBM82

WM090X0C

8 DIGITS VISUALIZED DIGITAL COUNTER WITH TWO THRESHOLDS, SUITABLE TO OPERATE LIKE:
BIDIRECTIONAL COUNTER,
SINGLE DIRECTIONAL COUNTER WITH DIRECTION UP/COUNT/DOWN/COUNT.
THE COUNTER LBM82 FINDS APPLICATION WHERE THERE IS THE NECESSITY TO VISUALIZE AND TO CONTROL, THROUGH TWO PROGRAMMABLE THRESHOLDS, BIDIRECTIONAL OR SINGLE DIRECTIONAL COUNTINGS FROM ELECTROMECHANICAL AND LOGICAL CONTACTS, PROXIMITY AND ENCODERS.
INSIDE THERE IS A BATCH COUNTER.



MAIN FEATURES

- Frontal keyboard in polycarbonate (antiscratch, antioil, antiacid)
- IP65 protection degree
- Accessible parameters with key software
- Removable terminals connection.
- Execution DIN 48 x 96
- Recessed assembly.
- Special retaining brackets.

PROGRAMMABLE PARAMETERS

- Two threshold
- Reset time
- Multiplication factor of the impulses
- Input (Slow/Fast)
- Count (Up / Down / Superior)
- Reset key
- Decimal point
- Counting input
- Auto Acknowledge of the Threshold
- Batch Counter
- Restart input

TECHNICAL FEATURES

- | | |
|---|--|
| - POWER SUPPLY IN ALTERNATE CURRENT | : single power 24 - 110 - 230 Vac (50 / 60 Hz). |
| - POWER SUPPLY IN DIRECT CURRENT | : single power 24 Vdc |
| - POWER SUPPLY TOLERANCE | : +10% - 15%. |
| - ABSORPTION | : 2 W - 3 VA. |
| - OPERATING TEMPERATURE | : -5 °C + 55 °C. |
| - CLIMATIC CONDITIONS | : U.R. 95 % at 40 °C (without condensate). |
| - COUNTER VISUALIZATION | : 6 digits, 14 mm high. |
| - BATCH COUNTER VISUALIZATION | : 5 digits, 14 mm high. |
| - MULTIPLICATION COEFFICIENT THE IMPULSES IN INPUT | : Programmable from 0,00001 to 9,99999. |
| - INPUT TYPE (NPN OR PNP) | : Suitable for bidirectional encoder, single directional encoder, Proximity, electromechanical and logical signals |
| - COUNTING FREQUENCY FOR LOGICAL SIGNALS | : Bidirectional encoders with 4 edges up to 24 kHz with 4 µSec between the edges
Bidirectional encoders with 4 edges up to 40 kHz
Single directional encoder with directional input up to 40 kHz
Upcounting / DOWNcounting up to 50 Hz
Programmable in 25%, 50% and 75% of the frequency |
| - MINIMUM TIME FOR SLOW INPUT SIGNALS | : from 10 to 50 Hz. |
| - CUT FREQUENCY FOR ELECTROMECHANICAL INPUTS | : 24 Vdc - 80 mA available on terminals. |
| - AUXILIARY INPUT POWER SUPPLY (version /5 /12 /24 VDC on demand) | : 12 Vdc - 80 mA available on terminals.
: 5 Vdc - 80 mA available on terminals. |
| - COMMAND INPUTS | : Counter reset.
: Counter restart.
: Inhibit / Auto acknowledge |
| - OUTPUTS | : 2 relays with operating contacts - capacity 2 A - 250 Vac. |
| - RELAY RESET | : Manual or automatic with excitation time from 0,1 to 99,9. |
| - PROGRAMMED DATA MEMORY | : Static (no battery) |

DESCRIPTION OF THE FRONTAL KEYBOARD

 **YELLOW**

The key '**LEFT ARROW**' in normal operating phase visualizes, blinking, all the programmings executed without the limitation of the insertion code. The time of scansion of the programmings is given from the pressure of the same key. It exits automatically from this phase after 5 sec of the last pressure of the same key.

In programming phase it moves the cursor of the figure towards left of a step, than at the beginning it is on the right side first one on the. At the end it resumes from the first one to right.

 **YELLOW**

The key '**UP ARROW**' in normal operating phase visualizes the Batch Counter.

In programming phase it increases the value of the blinking figure.

 **BLUE**

The key '**PRG**' pressed for 2 sec. allows to enter in the programming phase, visualizing on display C.0000.

In the programming phase, pressing key 'PRG' impulsively, it exits from the programming phase. The instrument exits automatically from the programming phase, 60 sec. after the pressure of the last key.

 **RED**

The key '**ENT/RES**' in normal phase of counting has the 'RESET' function, with the modalities to it attributed in the programming phase.

In programming phase it confirms and memorizes the visualized data and passes to the successive function. If it has arrived to list end it resumes from the beginning.

INPUTS / OUTPUTS DESCRIPTION

DC POWER
(inputs 1 - 2)

24V DC Power Supply of the instrument.

AC POWER
(inputs 3 - 4)

Power Supply of the instrument; it can be to 24 - 110 - 230 VAC according to demand.

12 VDC - 80mA
(inputs 6 - 7)

12 VDC - 80 mA auxiliary Power Supply that the instrument supply to feed Encoder and amplified proximity.

RESTART
(input 8)

RESTART input that executes the Restart of the counting from the programmed value in the RESTART register.

RESET
(input 9)

Input of RESET that executes the reset of the visualized count showed on display at the moment of its activation.

INHIBIT/AUTOACK.
(input 10)

When active, it operates as inhibit of the counting or as Auto Acknowledge of the value on the display as new Threshold value

CNT 1
(input 11)

NPN counting input (PNP on demand) suitable for electromechanical contacts, amplified proximity, 3 wires sensors, bi-directional and single directional Encoders.

CNT 2
(input 12)

NPN counting input (PNP on demand) suitable for electromechanical contacts, amplified proximity, 3 wires sensors, bi-directional and single directional Encoders.

RL1
(inputs 14-15-16)

Output of Relay 1, connected to the operation of the Threshold S1. The Common and Normally Opened contacts are available.

RL2
(inputs 17-18-19)

Output of Relay 2, connected to the operation of the Threshold S2. The Common and Normally Opened contacts are available.

DESCRIPTION OF THE LED'S OPERATION

LED 1

It comes activated to the reaching of the Threshold S1.

LED 2

It comes activated to the reaching of the Threshold S2.

PROGRAMMING OF THRESHOLD

For THRESHOLDS programming access, proceed as follow:

- Press key **PRG** in impulsive mode; on display appears:

S1
99999999

S.1 = THRESHOLD 1, value programmable between - 9999999 and 99999999. Its operating mode depend to the modality choose in the MODE parameter in GROUP 3.

S2
99999999

S.2 = THRESHOLD 2, value programmable between - 9999999 and 99999999. Its operating mode depend to the modality choose in the MODE parameter in GROUP 3.

Key **ENT** confirms the data and passes to the successive programming. In order to exit the programming, press key **PRG**.

PROGRAMMING OF THE OPERATION PARAMETERS

The programmable parameters are divided in two groups and protect with a 4 figures code.

In order to approach the programming, proceed in the following way:

- Press key **PRG** for about 2 sec. On the display appears:

Cod
0000

GROUP 1: insert code **2357** and press **ENT**.

t.r. 0 10

t.r. = Automatic Time Reset, programmable from 00,0 up to 99,9 sec. This parameter allows to the instrument to operate in **automatic** mode. When the counting reach the S1 value automatically it resets the counting, excites the relay RL1 and restart the counting without lose impulses. The relay RL1 remains ON for time programmed in t.r. programming. If the reset time programmed in t.r. is = 0 (00,0) the instrument operates in **manual** mode.

Particular case: if the set up time t.r. is smaller of the time employed from the count to arrive to the values of S.1 or S.2, the relative relays will never come unactivated.

100000
F.

F = 6 digits multiplier Factor, programmable from 0,1 to 9.99999. This parameter allows to convert the number of the input impulses, showing them on the display in another format. If it programmed = 0 it comes reprogrammed automatically to 1. If a value lower than 1 is inserted, it obtains the division of the impulses. Es. I want to divide for 25 the impulses in input; calculation $1 : 25 = 0.04$.

Attention: the variation of the value of the multiplying modifies automatically the value of the counting.

Cn UP
Cn dn
Cn Sp.

Cn. = Counting Mode: UP / DOWN / Superior.

UP = UP counting on rising edge

dn. = DOWN counting on rising edge

SP. = SUPERIOR, counting on rising edge getting over the Threshold.

Counting = Up: the counter gets ready to visualize the UP counting in rising edge mode, starting from zero up to the programmed value of Threshold. To the counting's end it activates the relative relay output.

Counting = dn: the counter gets ready to visualize the DOWN counting in rising edge mode, starting from the programmed value of Threshold to zero. To the counting's end it activates the relative relay output. This programming operates with positive Thresholds only; negatives Thresholds are reprogrammed to 0.

Count = Sp: The operation is similar to UP Counting with the difference that to the reaching of the threshold the instrument continues to count and can manually be resets to zero only. It operates with positive and negative Thresholds. With Superior Counting, each time that the thresholds are overcoming the Batch Counter is increased.

r.G. 000

r.G. = CLEARANCE RECOVERY

It's a 3 digit programmable value (0-999) that it's summed to the Threshold value.

(Example: S1 = 10000, r.G. = 20, S1 actives at 10020, S3 = -2000, r.G. = 20, S3 actives at -2020)

n.r. P.

M.r. = Automatic Reset Mode. This parameter allows to program which Threshold, negative or positive, must works in Automatic Reset. The instrument than will operate in the mode programmed in the GROUP 3 and with the thresholds values programmed.

P. = Two POSIVE Thresholds.

n. = Two NEGATIVE Thresholds.

P.n. = One POSITIVE Threshold and one NEGATIVE Threshold.

Two POSIVE Thresholds: The Automatic Reset works with the Threshold with the highest programmed value between the two Thresholds.

Example: two independent Thresholds; S1 = 10000, S2 = -12000, the Automatic Reset starts when it reaches the S1 value.

Two NEGATIVE Thresholds: The Automatic Reset works with the Threshold with the lowest programmed value between the two negative Thresholds.

Example: two independent Thresholds; S1 = 10000, S2 = -12000, the Automatic Reset starts when it reaches the S2 value.

One POSITIVE Threshold and one NEGATIVE Threshold: this mode integrates the two previous modes. The Automatic Reset can be starts when reach the positive threshold and the negative threshold.

Example: two independent Thresholds; S1 = 10000, S2 = -1000, the Automatic Reset starts when it reaches the S1 and S2 values.

Every time that the counting reaches a Threshold connected to the Automatic Reset the Batch Counter is increased. The Threshold not connected to the Automatic Reset operates in Superior mode.

When DOWN counting is programmed, it's not possible to have negative Thresholds.

Key **ENT** confirms the data and passes to the successive programming. In order to exit the programming, press key **PRG**.

PROGRAMMING OF THE OPERATION PARAMETERS

The programmable parameters are divided in two groups and protect with a 4 figure code.

In order to approach the programming, proceed in the following way:

- Press key **PRG** for about 2 sec. On the display appears:

Cod

0000

GROUP 2: insert code **2413** and press **ENT**.

APP. n

APP. = AUTO ACKNOWLEDGE.

This parameter allows to set on which threshold is active the Auto Acknowledge function. The function allows to memorize the value visualized on the display as threshold value. If the Auto Acknowledge function is active, when its input has closed, the value visualized on the display becomes the new threshold value. The temporary lighting of the frontal leds signals the acknowledged. The Acknowledge function remains active up to it has excluded by menu. When this function is not active, the input operates as INHIBIT, that inhibits the counting for all time long that it's close.

n. = Auto Acknowledge NOT ACTIVE. The INHIBIT function is active.

1 = Auto Acknowledge ACTIVE on THRESHOLD 1.

2 = Auto Acknowledge ACTIVE on THRESHOLD 2.

r.r.S

1000

r.r.s. = REGISTRO DI RESTART. Value programmable between -9999999 and 99999999. Every time that the RESTRT input is close, the programmed value is reload on the display. This programming is used to Restart the counting from a programmed value. It can be activated in Impulsive or Continuously mode.

P.d 0

P.d 1

Programming of the Decimal Point of the Counter.

This programming allows to add a decimal point to the visualization on the 5 digits, in order to obtain counts with various resolutions.

d.p. = 0 Decimal Point excluded; visualization 99999999

d.p. = 1 Decimal Point on the second display from right; visualization 999999,9

d.p. = 2 Decimal Point on the third party display from right; visualization 999999,99

d.p. = 3 Decimal Point on the quarter display from right; visualization 99999,999

d.p. = 4 Decimal Point on fifth display from right; visualization 9999,9999

Attention, the Decimal Point is only fictitious, it doesn't realize any conversion.

RES 2

res = RESET KEY MODE. Programmable function of the frontal RES KEY

1 = INHIBITED RESET. It's not possible to RESET with the RES key.

2 = ACTIVE RESET. It's possible to RESET with the RES key.

3 = IMPULSIVE RESTART. The RES key operates as Impulsive RESTART.

bl.S n

bl.S. = BLOCK OF THE PROGRAMMING OF THE THRESHOLD. This programming prevent the access of the threshold programming.

n. = BLOCK NOT ACTIVE, it's possible to access to the thresholds programming.

Y. = BLOCCO ACTIVE, it's not possible to access to the thresholds programming.

r.r.S 1

r.r.s. = RESTART INPUT MODE

This programming sets the operating mode of the RESTART function:

I. = IMPULSIVE RESTART

C. = CONTINUOUSLY RESTART WITH UNACTIVATION OF THE COUNTING.

IMPULSIVE: when active, the counter reload on display the value programmed in the Restart register without stops to count. This command is instantaneously elaborated (interrupt mode).

CONTINUOUSLY: when active, the counter reload on display the value programmed in the Restart register and remains stopped up to when the input becomes unactive.

In.r.

In.r. = INPUT RESET MODE. This programming sets the operating mode of the Reset Input.

1 = The Reset Input resets the counting on display, the normal counting or the Batch Counter, depending on what is showed on display.

2 = The Reset Input contemporaneously resets the counting and the Batch Counter.

AS r.

A.S. = Threshold Activation.

With this programming is possible to active the new Threshold value directly quitting the programming or quitting the programming after a Reset (with frontal RES key or with Reset input).

A.S. = P. Threshold activation quitting the programming.

A.S. = r. Threshold activation quitting the programming after a Reset.

Key **ENT** confirms the data and passes to the successive programming. In order to exit the programming, press key **PRG**.

PROGRAMMING OF THE OPERATION PARAMETERS

The programmable parameters are divided in two groups and protect with a 4 figure code.

In order to approach the programming, proceed in the following way:

- Press key **PRG** for about 2 sec. On the display appears:

Cod

0000

GROUP 3: insert code **2359** and press **ENT**.

Modo

Modo = Selection of the operating mode of the CNT1 e CNT2 inputs.

bidi. 4 = BIDIRECTIONAL ENCODER, COUNTING ON 4 EDGES

bidi. 1 = BIDIRECTIONAL ENCODER, COUNTING ON 1 EDGE

Mono = SINGLE DIRECTIONAL, COUNTING on CNT1 input and DIRECTION on CNT2 input

Inc. dec = UP / DOWN COUNTER, INCREASING on CNT1input and DECREASING on CNT2 input

Fr.t.

Fr.t. = Cut Frequency for the Single Directional and UP / DOWN Counter modes.

This programming sets the Cut Frequency of the filter of the counting inputs.

This programming is available for the counting inputs programming **Mono** and **Inc Dec** only.

10 = SLOW up to 10 Hz

20 = SLOW up to 20 Hz

50 = SLOW up to 50 Hz

F. = FAST up to 40 kHz (not available for **Inc. Dec** programming)

dc. 25

D.C. = DUTY CYCLE FOR THE SLOW CUT FREQUENCY.

This programming sets the duty cycle for the slow cut frequency programmed (not available for the **Fast** or **bidi** programming).

25 = DUTY CYCLE 25 %

50 = DUTY CYCLE 50 %

75 = DUTY CYCLE 75 %

Setting 10 Hz (period = 100 mSec) and duty cycle 25 %, the impulse, to be read, must have a minimum ON time of 25 mSec and a minimum OFF time of 75 mSec. The cut frequency and the duty cycle are elaborated with a digital software filter; in this mode it's possible to guarantee the maximum precision also after many years of work.

MS 1

M.S. = OPERATING MODE OF THE THRESHOLDS

This programming sets the operating mode of the Thresholds.

- 1 = S1 MAIN THRESHOLD, S2 SECONDARY THRESHOLD IN OFFSET
- 2 = S1 MAIN THRESHOLD, S2 SECONDARY THRESHOLD IN ABSOLUTE
- 3 = TWO INDEPENDENT THRESHOLDS

In **MODE 1**, S2 = OFFSET, S2 is a threshold that comes activated always ahead the main threshold S1. The programmed value is the value of the advance with which S2 will be active respect the threshold S1.

If S1 threshold is set 10000 and S2 is set 1000, the relay RL2 will be ON to 9000 and the Relay RL1 to 10000. If we change the S1 value, the RL2 will always be ON 1000 in advance respect S1.

The main threshold S1 can have a positive or negative value while S2 will always be a positive value, being an Offset value. With positive values of S1, S2 can be programmed between 0 and S1 value. (Example. S1 = 10000, S2 between 0 and 10000).

With negative values of S1, S2 can be programmed between 0 and the absolute positive value of S1 minus 1. (Example. S1 -20000, S2 between 0 and 19999).

If it's programmed with a value out of this range it's automatically reprogrammed to (S1-1).

In **MODE 2**, S2 = ABSOLUTE, S2 is an independent threshold that operates in SUPERIOR mode and must be programmed between 0 and S1 value. If we change the S1 value, the S2 value doesn't change. With positive values of S1, S2 can be programmed between 0 and S1. (Example. S1 = 10000, S2 between 0 and 10000). With negative values of S1, S2 can be programmed between 0 and the value of S1 plus 1 (example S1 = -20000, S2 between 0 and -19999).

If it's programmed with a value out of this range it's automatically reprogrammed to (S1-1) or (S1 +1).

In **MODE 3** all the thresholds are programmable in independence mode.

Key **ENT** confirms the data and passes to the successive programming. In order to exit the programming, press key **PRG**.

PROGRAMMING OF THE OPERATION PARAMETERS

The programmable parameters are divided in two groups and protect with a 4 figure code.

In order to approach the programming, proceed in the following way:

- Press key **PRG** for about 2 sec. On the display appears:

Cod

0000

GROUP 4: insert code **2415** and press **ENT**.

P. 0000

P. = BATCH COUNTER

If programmed = 0, the Batch Counter is an absolute counter with 5 digits in increase that totalizes the number of cycles. If it's set to a value, it's a Batch counter in decrease, starting for the value to 0. When it reaches the 0 the counting is stopped with the Relays ON up to a Reset with the frontal RES key or by the Reset input. In this case the Restart command is not active.

Key **ENT** confirms the data and passes to the successive programming. In order to exit the programming, press key **PRG**.

MODO DI FUNZIONAMENTO

MODE	OPERATING DIAGRAM		OPERATING DESCRIPTION
BIDI x 1	CNT1		CNT1, counting on an edge, for signals 90° out of p phase.
	CNT2		CNT2 input, executes the inversion of the counting's direction when it's ahead CNT1.
	UP	0 1 2 3 4 5 4 3 2 1	Increasing visualization, from 0 to S programmed Threshold value.
	DOWN	S S-1 S-2 S-3 S-4 S-5 S-4 S-3 S-2 S-1	Decreasing visualization, from S programmed Threshold value to 0.
BIDI x 4	CNT1		CNT1, counting on rising and falling edge, for signals 90° out of phase.
	CNT2		CNT2, counting on rising and falling edge, executes the inversion of the counting's direction when it's ahead CNT1.
	UP	0 1 2 3 4 5 6 7 8	Increasing visualization, from 0 to S programmed Threshold value.
	DOWN	S S-1 S-2 S-3 S-4 S-5 S-6 S-7 S-8	Decreasing visualization, from S programmed Threshold value to 0.
DIR	CNT1		CNT1, single directional counting input of the impulses.
	CNT2		CNT2, executes the inversion of the counting's direction from increasing to decreasing and vice versa.
	UP	0 1 2 1 0 -1 0 1 2	Increasing visualization, from 0 to S programmed Threshold value.
	DOWN	S S-1 S-2 S-1 S S+1 S S-1 S-2	Decreasing visualization, from S programmed Threshold value to 0.
INC/DEC	CNT1		CNT1, single directional counting input in increasing mode
	CNT2		CNT2, single directional counting input in decreasing mode
	UP	0 1 2 3 2 1 0 0 1	Increasing visualization, from 0 to S programmed Threshold value.
	DOWN	S S-1 S-2 S-3 S-2 S-1 S S S-1	Decreasing visualization, from S programmed Threshold value to 0.

SENSORS CONNECTIONS

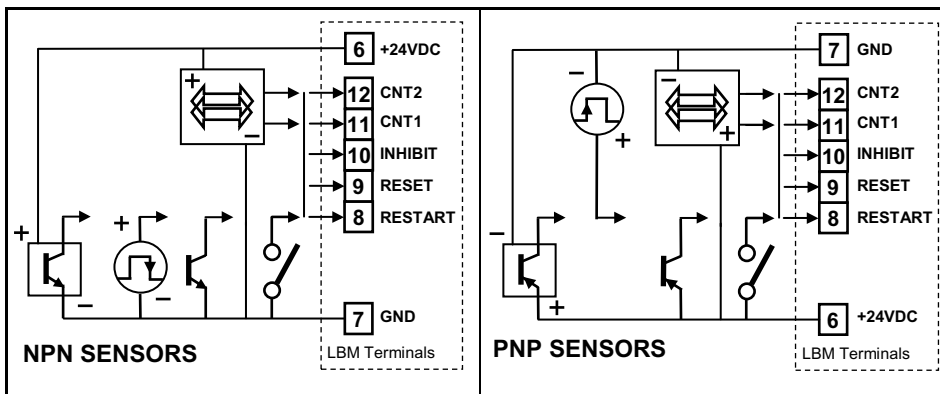

KEY

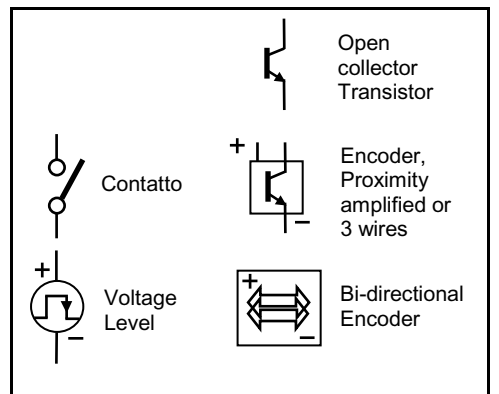

CONNECTIONS IN NEGATIVE LOGIC NPN

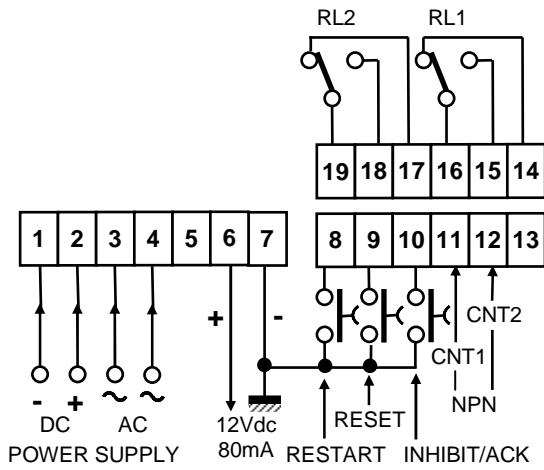

24 VDC POWER SUPPLY

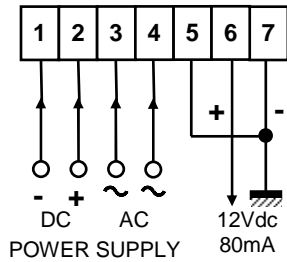

When the instrument is fed to 24 VDC connect the input 5 and 7 as showed.

CONNECTIONS IN POSITIVE LOGIC PNP

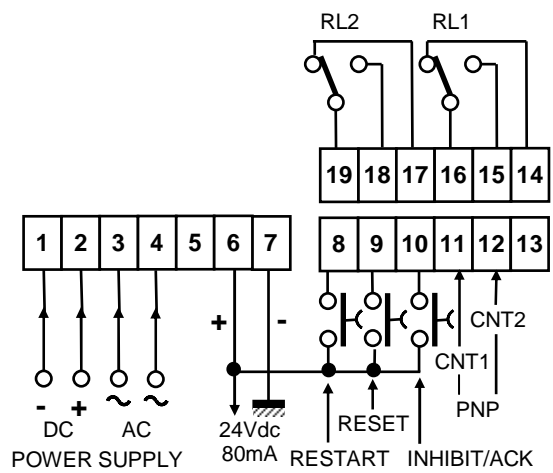

TRANSISTORS OUTPUTS

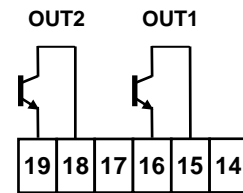

Max. Voltage 30VDC - Max. Current 100 mA

OVERALL DIMENSIONS (mm)

FRONTAL

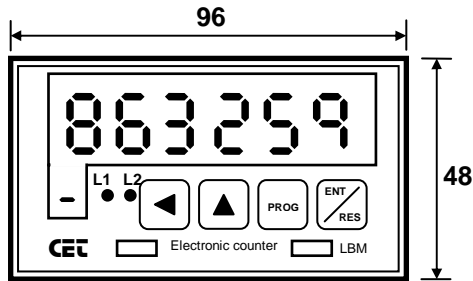

SIDE

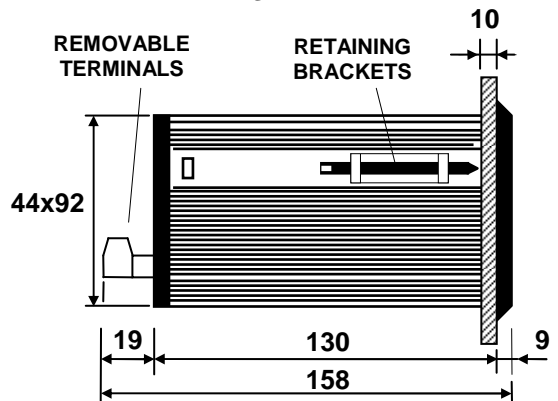

REAR

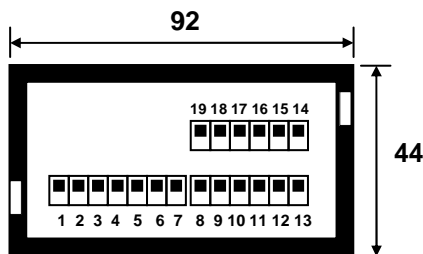

DRILL TEMPLATE

