



# Index

General .....	3
Technical specifications .....	4
Dimensions .....	4
Terminal connections .....	5
Front panel and keys .....	6
Configuration .....	7
Configuration parameters .....	8
Output 0/4-20 mA and 0..10 V (option) .....	10
Output connections .....	10
Alarm (option) .....	11
Alarm relay connections .....	11
Serial output RS-485/RS-232 (option) .....	12
Serial output connections .....	12
Serial communication .....	13
Serial protocol (SCL) .....	13
Secret code .....	14
Field display 2800 construction .....	15

**Manufacturer:**  
***Nokeval Oy***  
**Yrittajakatu 12**  
**FIN-37100 NOKIA**  
**Tel. +358 3 342 4800**  
**Fax. +358 3 342 2066**

# Field display 2800-2041 for strain gauge sensors

- Strain gauge sensors with 4- or 6 -wire connection
- Excitation voltage 10V to sensors, max 150 mA
- 6-digit processor-based LED-display
- Settings via front panel keys
- Output 0/4..20 mA, 0..10 V
- Serial output RS-232 or RS-485
- 2 - 4 alarm relays
- Display taring via front panel key
- Measuring accuracy < 0,05 % of span
- Power supply 85..240 VAC or 12..32 VDC/ 24 VAC



The versatile display 2041 is designed for strain gauge sensors. Strain gauge sensors can be connected with 4 or 6 wires. The 6-wire connection removes the lead wire resistance, as bridge voltage is measured from the sensor poles, and therefore it is recommended for applications requiring very high accuracy. The panelmeter provides 10V excitation voltage for sensors, max. four 350 ohm sensors. Options to the 2041 include output 0/4-20 mA, 0-10V, 2..4 alarms or serial output RS-485/232.

Display scaling and taring is easy via front panel keys. Scaling can be carried out in two different ways, either by applying the mV values of the bridge or using the teaching function. The teaching is done by first loading the sensors with the min. weight and then with the max. weight, after which the meter will automatically count the scaling.

In applications where the sensor loading is not in balance a separate serial connection unit of the sensors 20 SA-4 can be used to prevent the nonlinearity caused by the imbalance. There are two power supply alternatives: one for line voltage 85..240 VAC and the other 12..32 VDC/ 24 VAC, both

galvanically isolated from input and output. Analog conversion is done by a 16-bit AD-converter (resolution 1/64000) and the number of measurements is 3 per second. Separate passwords can be set for access to the configuration menu and alarms. The display can be damped with a digital filter if necessary. The number of decimals on the display is selectable. Field display 2800 protection rating is IP65.

The series 2000 is very flexible and easy to modify by changing input cards for different kinds of sensors, such as temperature sensors, pulse sensors, serial inputs etc. The modification does not require any calibration. The optional cards are the same for all the instruments in this product family. Each panelmeter type has its own datasheet.

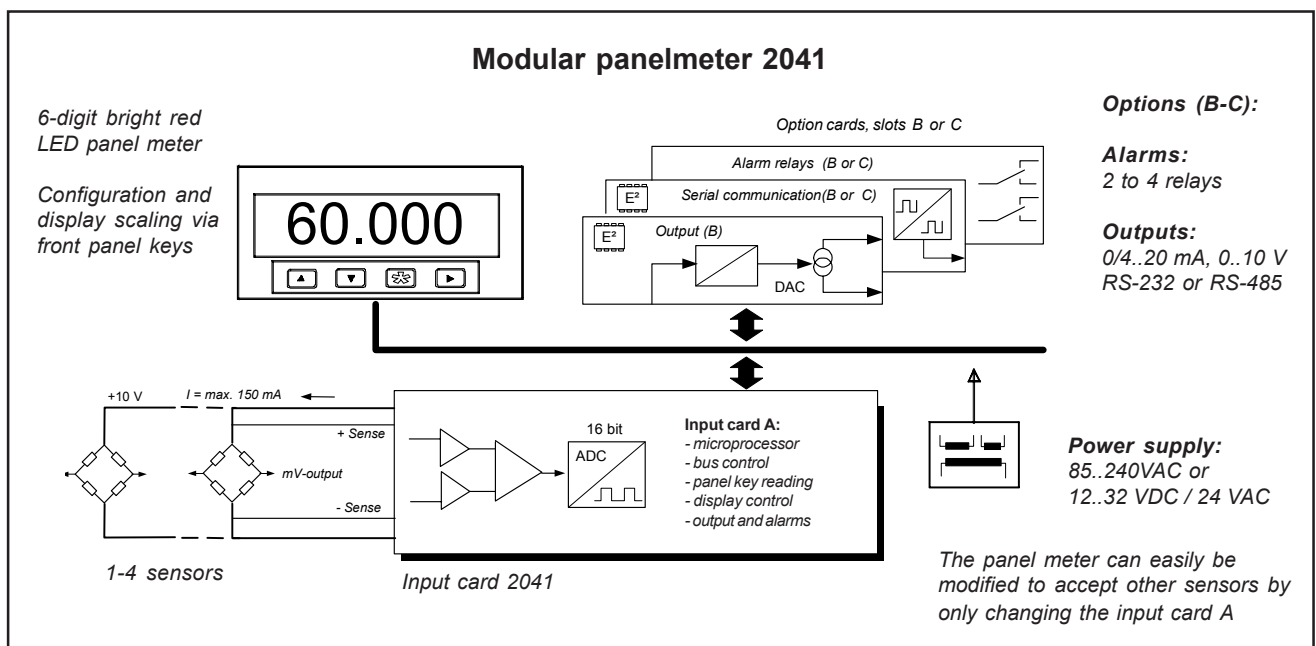

# Technical specification:

Sensor strain gauge, max 350ohm parallel  
 Sensor connection 4- or 6 -wire connection  
 Bridge connection full bridge or half bridge  
 Bridge supply 10 VDC, max. 150 mA  
 Measuring range 25..50 mV  
 Sensitivity settings mV/V, freely selectable  
 Accuracy <0,05 % FS  
 Repeatability <0,02 % of span  
 Temperature drift 0,0028 % /°C

### Output (option):

Outputs 0..20 mA, 4..20 mA and 0..10 VDC  
 Output range scaleable on the whole display range,  
 scaling via front panel

Accuracy 0,05% of the scaled display range  
 Galvanic isolation test voltage 2000 VDC  
 Load resistance maximum 700ohm

### Alarms (option):

Relays 2..4 alarm relays, max 230 VAC / 2A  
 Optional cards 2000-REL2 or 2000-REL3, 4 relays (2x 2000-REL2)  
 prevent the use of other options

### Serial output (option):

Serial output RS-232 and RS-485  
 Only for measurement reading or setting of alarms  
 Baud rate 300, 1200, 2400, 4800, 9600 or 19200

### General:

Display range 6 digits, bright red LED , digit height 20 mm, brightness selectable on the whole range via front panel  
 Display scaling on the whole range via front panel keys  
 Display taring via front panel keys  
 Teaching function applying min/max weights  
 Configuration via front panel keys  
 Case 130 x 180 x 80 mm  
 Front panel protection IP65  
 Operating temp. 0..60 °C  
 Terminals detachable, max. 1,5 mm<sup>2</sup>  
 Power supply 85..240 VAC or 12..32 VDC / 24VAC  
 Weight 500 g

### How to order: 2800-2041-OUT-REL2-24VDC

Type  
 Output OUT  
 Alarm card REL2  
 Power supply:  
 85..240VAC or  
 12..32VDC/24VAC

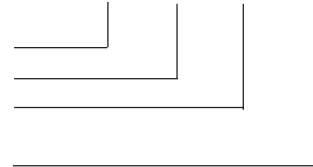

### Optional cards (2 options available at a time):

Output card 2000-OUT  
 Alarm card, 2 relays 2000-REL2  
 Alarm card, 3 relays 2000-REL3  
 Serial output, RS-232/485 2000-RS

*(When ordering a field display, the "2000" of the cards is left out.)*

### Case dimensions:

#### Enclosure:

Light gray  
 Polykarbonate  
 Glands PG11 (3).

Removable mounting brackets

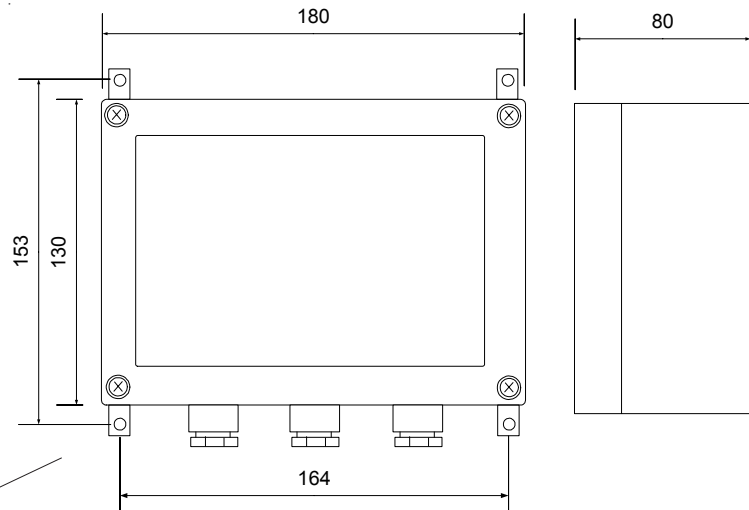

## Terminal connections:

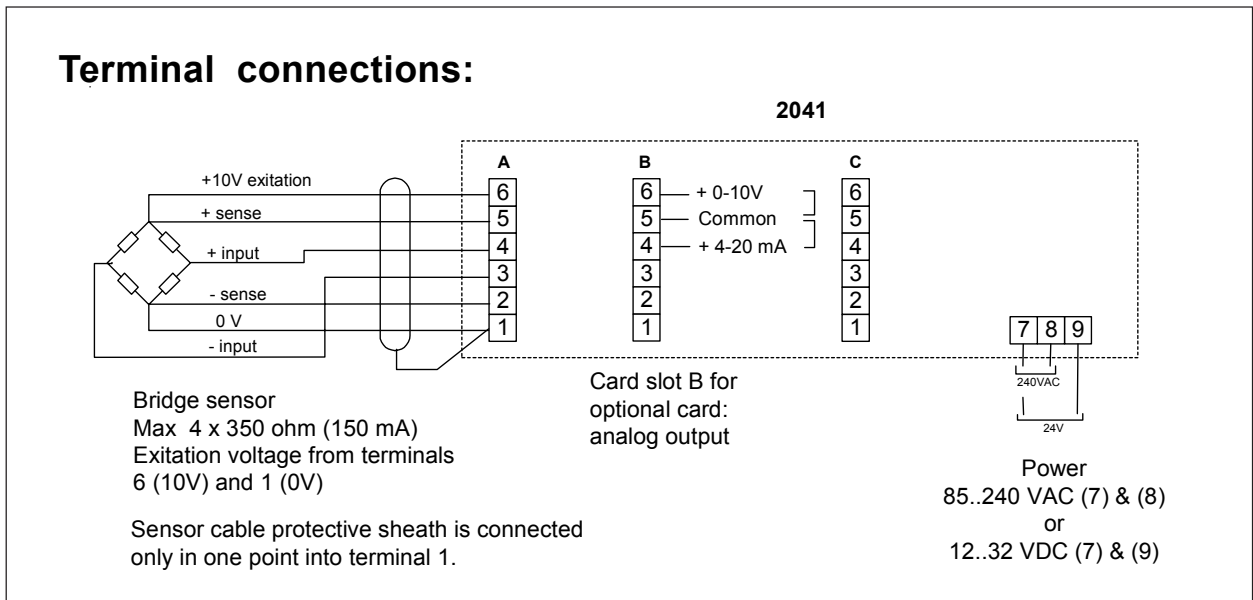

### Connecting bridge sensor with 4- or 6- wires:

Bridge sensors excitation voltage is measured directly from sensor poles. Processor corrects display value if voltage differs from 10 Volts. Selected 6-wire connection technique enables also use of separate voltage supply which voltage may vary between 7..13 V. Unit accepts also 4-wire connection but then the sense wires must be connected to voltage supply terminals (short cut 5-6 and 1-2). This 4-wire connection can be used if the accuracy demand is unimportant or if the sensor lead wire error is corrected by rescaling the display with known error.

If the sensor is not connected with 6-wires the lead wire resistance will reduce the excitation voltage and display shows too low values. How big this error is depends on the current level in wires and on line resistance.

An example: If the line resistance on each sensor is 2 ohms it means that four 350 ohm bridges in parallel causes 87,5 ohm load to 10 V excitation voltage.

### 4-wire connection

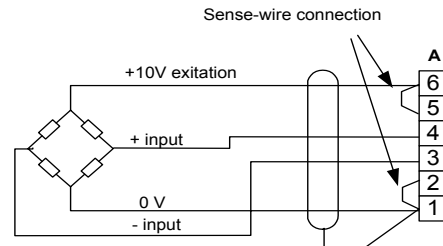

Bridge sensor

Sensor current can be calculated as:  $10V/87,5 \text{ ohm} = 114,2 \text{ mA}$ . Voltage in bridge poles is then:  $10V - (114,2 \text{ mA} \times 2 \text{ ohm}) = 9,776V$ .

Sensor message is 2,24 % too low compared to 10.000V excitation voltage. Bridge excitation voltage is directly comparable to received mV-input and vice versa. Model 2041 has continuous excitation voltage measurement function and therefore voltage don't have to be exact in bridge poles.

### Half bridge connection:

Model 2041 accepts also half bridge sensor. This is an optional function which must be specified when ordering the unit. Unit which is ordered for half bridge sensor can be used with full bridge connection by replacing the short cut jumper as drawn below.

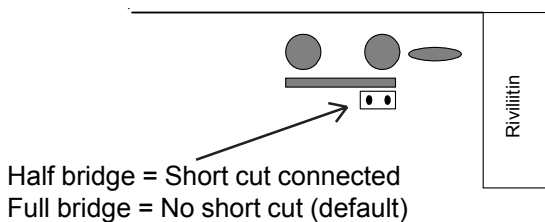

Half bridge connection in below picture. Terminal 3 is not connected. Sensor cable protective sheath is connected only in one point into terminal 1.

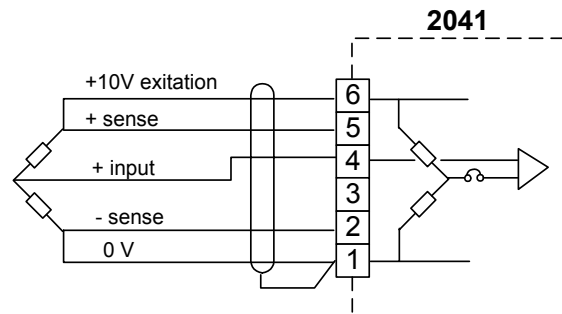

Half bridge connection

# Front panel and keys

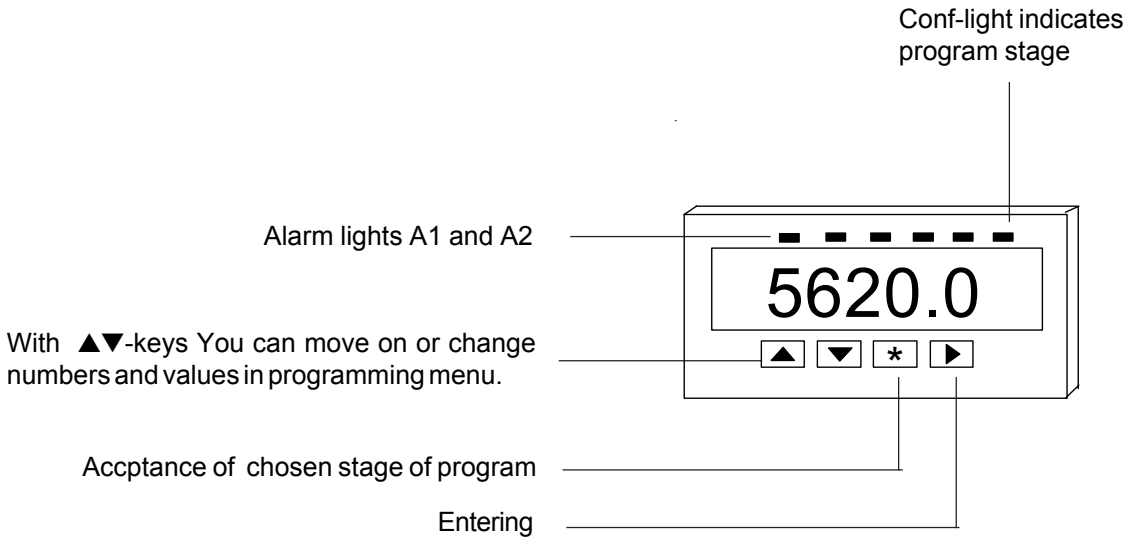

## Display Tare procedure:

Press and hold ★ until display shows 0000 (approximately for 3 s). Press ★ again and display is tared and ready to measure.

## Configuration

You can enter configuration stage by pressing two seconds ▲ and ★-keys at same time. In program stage f. ex. scaling of display, sensor selection and alarm mode are chosen. See closer in chapter programming.

## Setting of alarms

By first pressing of ► key you can see setpoint of alarm one (A1), correspondingly by second pressing setpoint of alarm two (A2) etc. Third pressing returns display to normal stage. Alarm indication light blinks showing that alarm has been set (if you do not touch keys you come to normal stage automatically).

When indication light blinks (A1 or A2) you can change alarm value by pressing ▲ and ▼ key. You may have optional alarm relays for each alarm level. Alarm mode, hysteresis and other settings must be set in configuration menu. If you do not touch keys during 8 seconds display returns to normal state automatically and save settings.

### Setting of alarm value

You can set alarm value by ▲▼-keys number by number. Setting starts from largest number from left to right. You may go to next number by ►-key. Exit by ★-key.

Number setting

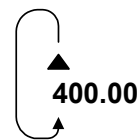

▲▼  
Numbers  
0...9 and , (decimal)

# Configuration

You can enter configuration state by pressing two seconds **▲** and **★** keys at same time. By arrow keys **▲** and **▼** you can move upwards and downwards in main menu. By pressing **▶** key you can enter configuration state at wished point. From setting state you can skip direct to save state or to previous

level with **★** key. You may set alarms in configuration or in display stage. Alarm levels can be set in configuration state or measuring state. You can cancel changes by selecting text **UnDo** to display and by pressing **▶** key. Next page describes in more details configuration functions.

## Configuration start:

Press two second **▲** and **★** keys at same time

## Description

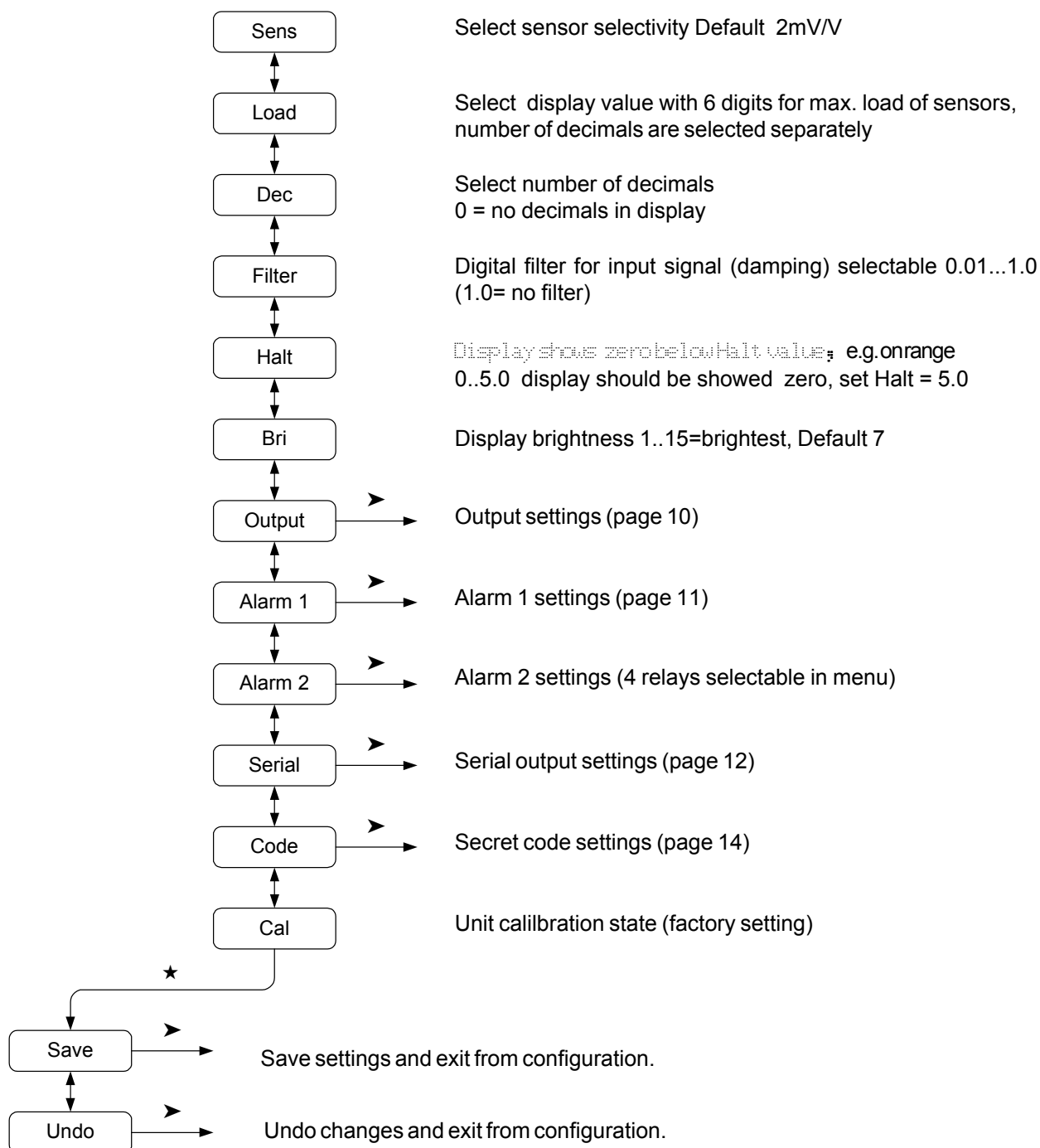

# Configuration parameters

## Sense

Typical sensor sensitivity is 2 mV/V which you will find in label of sensors. Change SET value according to sensitivity of sensors. Changing this value will have reserved effect on display. For example changing default selectivity 2 mV/V to 2,2 mV/V, display reading will reduce 10%.

Measuring range is defined from selectivity as follows  
Sensor selectivity 2 mV/V is multiplied with the bridge voltage. If selectivity is 2 mV/V and the bridge voltage is 10 V the input measuring range will be 20 mV (2 mV/V x 10V =20 mV).

## Load: Set or Teach

You can make scaling by two different ways as follows:

**SET** selection indicates the weighing value which gives the maximum signal from the bridge. Unit uses this value to calculate the maximum mV-signal with maximum load on sensor. If display value is e.g. 5% too low you can fix the display by increasing the Load value 5%.

**Teach** selection gives possibility to use reference loads for scaling, see page 9.

## Dec

Number of decimals in display. Select 0...5 with st-keys and accept with H-key.

## Filter

Display filtering. Filtering damps restless display by large number values. Measuring interval is 0,4 s.

Value setting between 1(min) ..0.010 (max).

1.000 = no filter

0.200 = normal filtering

e.g. 0,2 =(1/5) one new value + 4 old values

or 0,1=(1/10) one new + 9 old values (very steady)

## Halt

Display can be set to show zero below Halt value e.g. the display should be showed zero when weighing value is under 10, set halt value 10. You can use also negative values.

## Bri

Display brightness 1..15 = brightest. Default 7.

## Output (option)

Output settings. See chapter "Output"

## Alarm 1 and 2 (option)

Alarm settings. See chapter "Alarm"

## Serial (option)

Serial output settings. See chapter "Serial output"

## Code

Secret code settings. See chapter "Secret code"

## Cal

For factory settings

## Undo, Save

Exit from configuration stage without saving changes (*Undo*) or save and exit (*Save*).



# Scaling of display

Display can be scaled on two different ways.

Select **LOAD** in menu and press ►-key.

**SET:** Enter display value on max.loading signal from bridge.  
 Example: If sensor gives 2 mV/V and supply voltage for sensor is 10 V, max signal from bridge is 2 mV/V x 10V = 20 mV. If you like to show 5000 for max input signal (20mV), SET value = 5000. The display range is now 0-5000 on input 0-20 mV.

**TEACH:** You can teach scaling of display by using two reference loads.

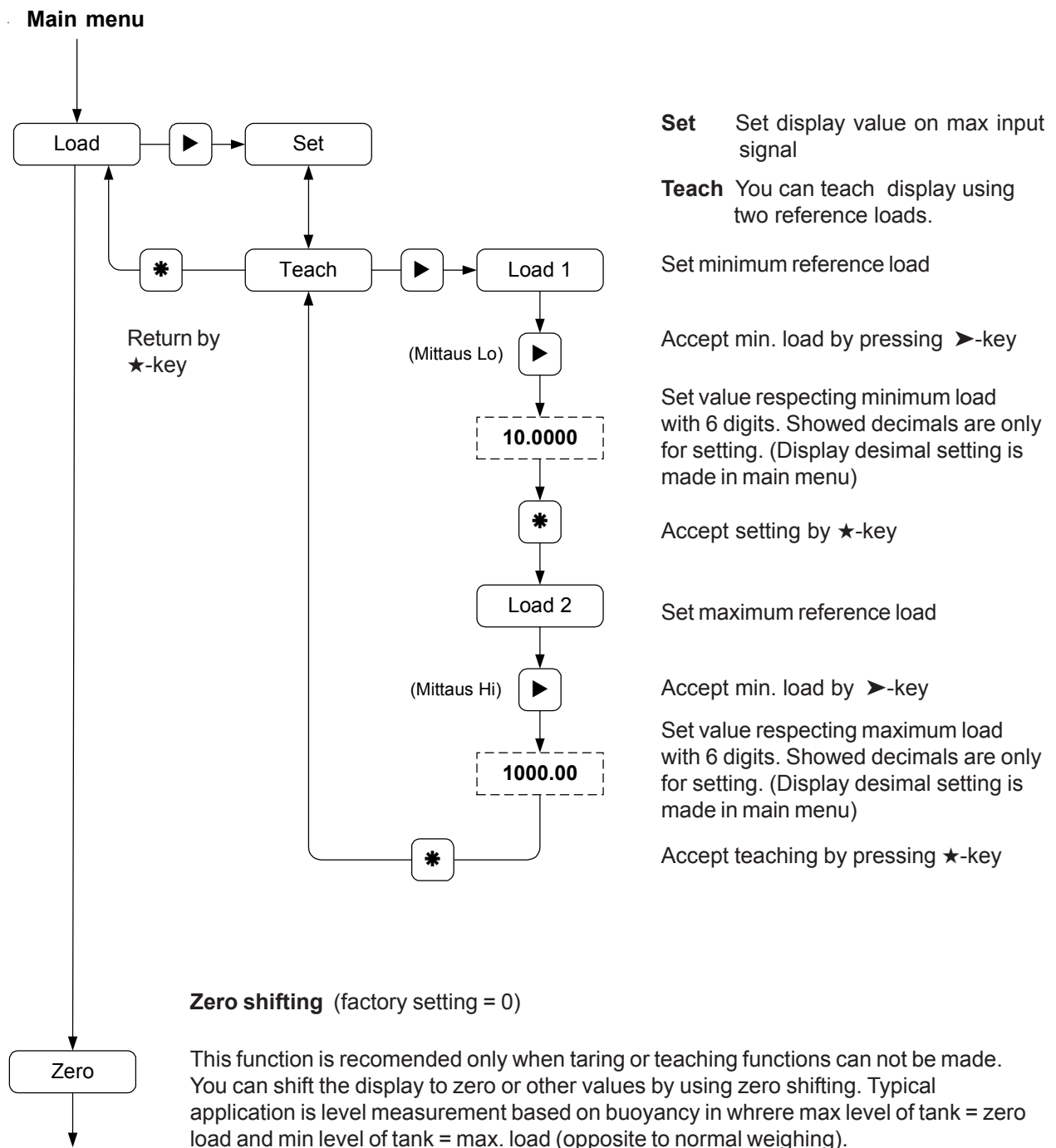

# Output 0/4-20 mA and 0..10 V (option)

The display may be provided with isolated output, ranges 0..20 mA, 4..20 mA or 0..10 V, which are programmable. You can mount output card to slot B or C (default B). Calibration information is saved to card and no cali-

bration is needed in configuration. You need not select card in programming because meter recognizes the mounted card. Programming: select **Output** selection in main menu and press ► key. See below description.

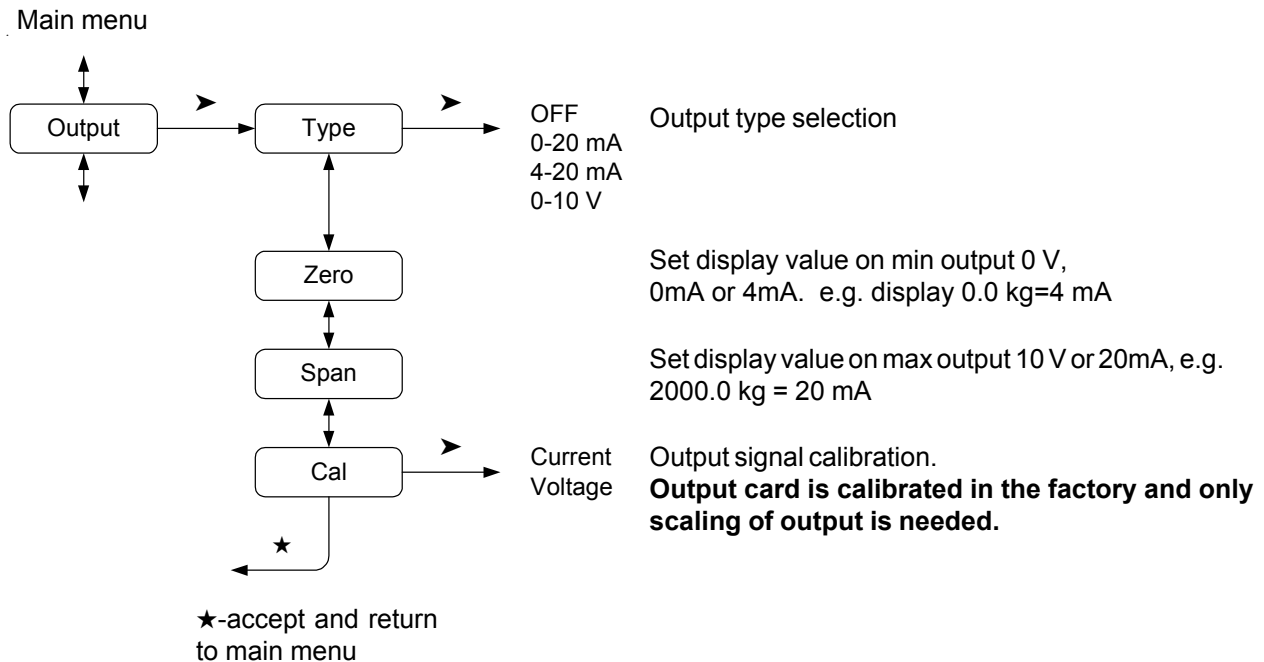

## Output connections

### Output 0-10V

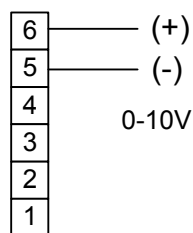

Slot B

### Output 4-20 mA

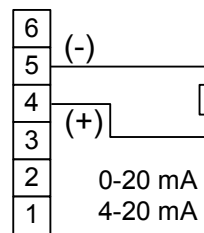

Slot B

# Alarm (option)

Meter may be provided optional alarm relay card (2000-REL2). In REL2 card is two relays with change over contact. Both relays can be setting in configuration state: alarm level, hysteresis, alarm type and

relay direction. When all alarm settings is done in configuration mode, alarm levels can be easily changed with frontpanel keys in normal measuring state. See chapter "Front panel and keys".

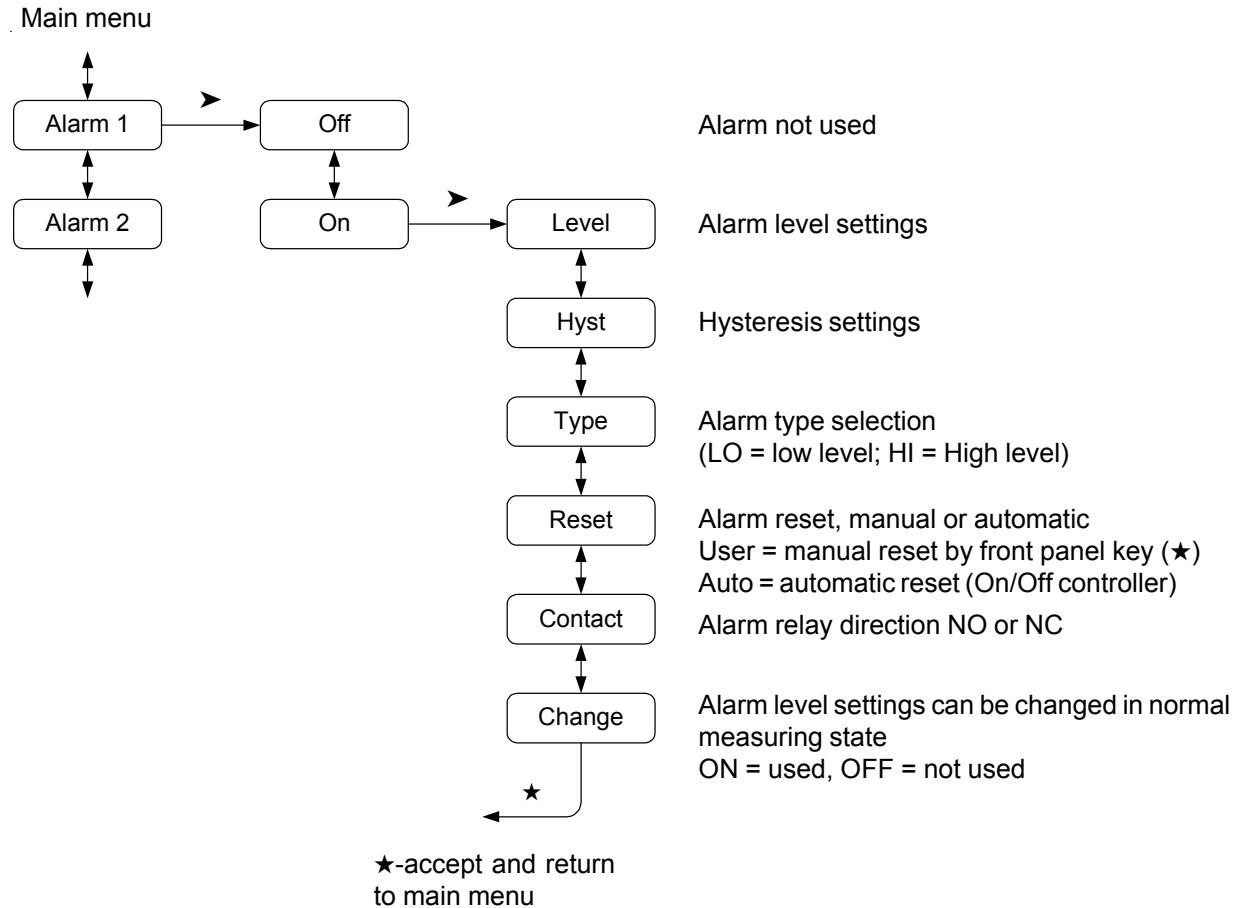

## Alarm relay connections:

2000-REL2

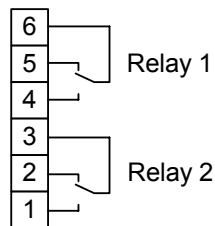

max. 260 VAC, 2 A

2000-REL3

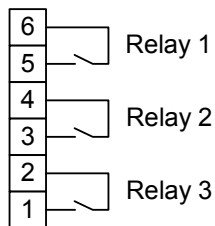

max. 260 VAC, 2 A

2000-I/O

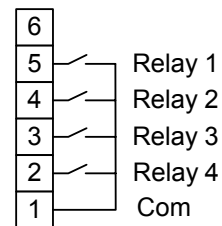

max. 60 V, 100 mA

# Serial output RS-485/RS-232 (option)

Meter may be provided with optional serial output and you can read measurements by e.g. PC. Display programming can not be made via serial port. Additional card provides serial signal RS232 and RS485, only one of those can be selected.

Serial signal is isolated from both input signal and power supply. Meters with RS485 can be max. 31 in same loop and longest distance 1000m. RS232 enables only connection of one meter and max. distance 10..20 m.

In config state you can first select card type (serial) mounted to slot B or C and then address and Baud rate. baud rates are: 300, 1200, 2400, 4800, 9600, 19200 and addresses 0...127.

Program remembers card type mounted, if it has been saved by save command when leaving program. In case you can not choose serial card, slot has automatically recognized card (plug and play).

Main menu

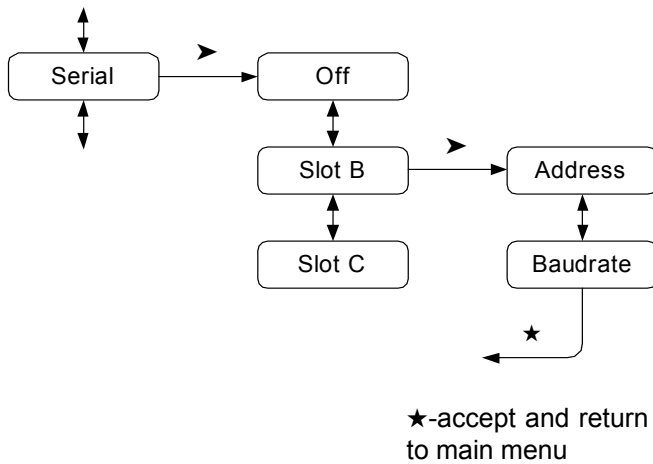

Serial output RS485 not used

Serial output card installed to the Slot B.  
Serial address selection 0..127

Baud rate selection

## Serial output connections:

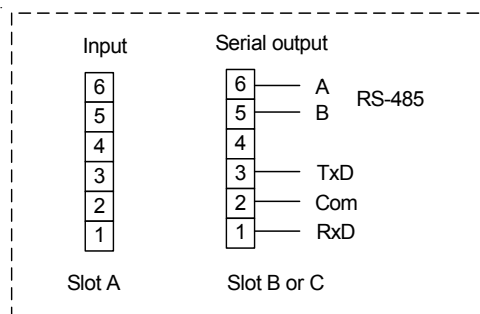

When using serial signal RS485 last unit must be terminated 110 ohm resistor. You can make termination at terminal connectors or connecting jumper Term to ON position.

## Serial output card

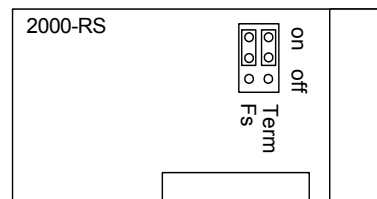

Term = terminated resistor, Fs = Fail safe

RS232                      RS485                      RS485  
                                 other units on bus                      Last unit on bus  
                                 (Factory settings)

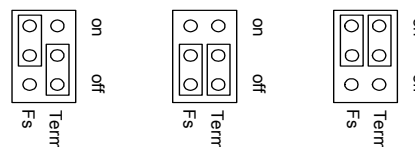

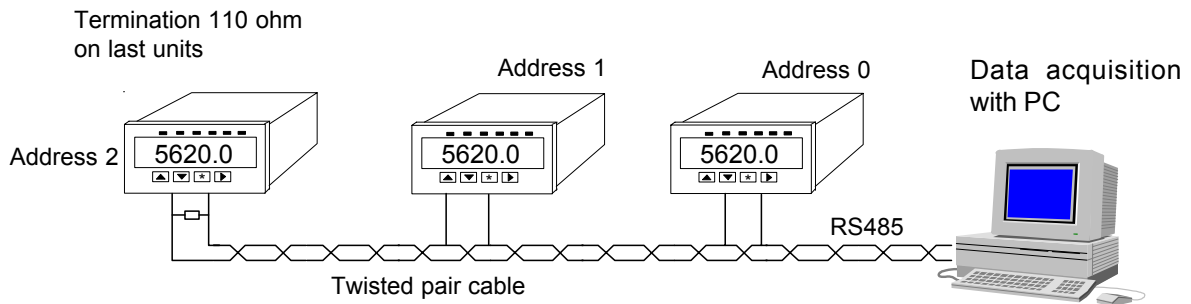

## Serial communication

Baud rate: 300, 1200, 2400, 4800, 9600 and 19 200  
1 Start, 8 Data and 1 Stop bit, no parity.

## Serial protocol (SCL)

MESSAGES: When asking the measurement data from the panelmeter 2041 through the serial port, a command sequence which is in accordance with the SCL protocol is used for the inquiry.

**<ADDR+80h>COMMAND STRING<ETX><BCC>**

### <ADDR>

The first byte character to be sent contains the address of the destination device and at the same time functions as the start indicator of the command. The uppermost bit of this byte is set, in other words 80H (128 in decimal) is added to the address.

COMMAND STRING: When measurement data is requested, the actual command is: MEA CH 1 ? , in which 1 means the channel number. (there is only one channel in the panelmeter 2041 so the number is always 1).

### <ETX>

<ETX> mean the end mark of the command, ASCII character 03h.

### <BCC>

Finally the checksum is calculated using XOR operation on the byte characters of the actual command including the ETX, excluding ADDR byte. In the example the ASCII codes have been presented in hexadecimal.

### e.g.

One wants the measurement result from the display unit address 1. An inquiry is sent:

MEA CH 1 ? (ASCII codes shown for <BCC> calculation)

M E A C H 1 ? <ETX> <BCC>  
4Dx45x41x20x43x48x20x31x20x3F x03 = 6F

(XOR operation is presented with a character x)  
(ASCII code 20h corresponds to space character)

So the following bytes are sent to 2041:

81 4D 45 41 20 43 48 20 31 20 3F 03 6F

RETURN MESSAGE: The answer from the panelmeter 2041 is obtained in the following format:

**<ACK>RETURN MESSAGE<ETX><BCC>**

### <ACK>

The first byte of the answer contains the start of the answer <ACK> (ASCII-code 06h) and the answer itself, endmark <ETX> (ASCII-03h) and the checksum of the answer which is calculated from all the byte characters of the answer including <ACK> and <ETX>. 2041 counts the checksum in which case the receiver does not need necessarily to care about it.

### e.g.

e.g. When a measurement result is for example 21.3, it will be obtained from the panelmeter in the following form

<ACK> 2 1 . 3 <ETX> <BCC>  
Answer: 06 32 31 2E 33 03 1B

# Secret code

You can enter secret code by pressing six time keys (1-4) in wished order (lines goes forward in display). Setting must be repeated in same order before new setting is accepted. For example: Press one after another keys ▲▲★▶▲▲ and once more ▲▲★▶▲▲. You may think the keys as numbers from left to right 1,2,3,4 in order to help recording and remembering.

e.g.



Input code ▲▲★▶▲▲ and once more.  
Example number value would be 113411.

In menu position **Code** press ▶ key and move on to selection state.

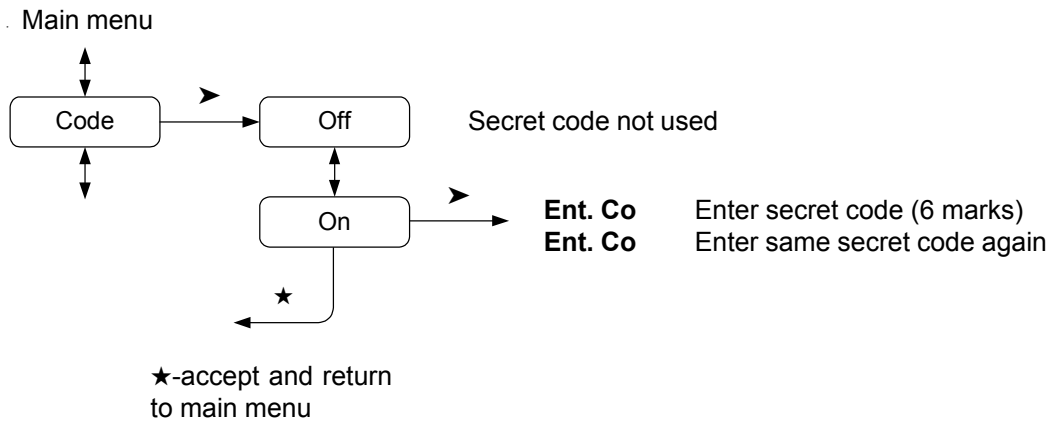

# Field display 2800-construction

The 2800 series field displays are modular and easy to assemble. According to customers wishes. The basic construction consists of mother board with three slots, A, B and C. Slot A determines meter type and provides always input signal. Slot B and C are interchangeable. As factory delivery input signal is always installed into slot A, mA output into slot B and alarms into slot C. In case of f.ex 4 alarms and relay card with 2 change-over contact (2 + 2 relays) are used, you must place second relay card into slot B. If you accept

only closing or opening relay contacts, you need only one relay card with 4 relays placed into slot C. The slot B is now usable for other optional outputs. You can have different types of meters by only changing the input card in slot A. Data sheet of each type of meter dictates the possible combinations. Recalibration of card is not needed; only scaling and other settings must be set by front panel keys.

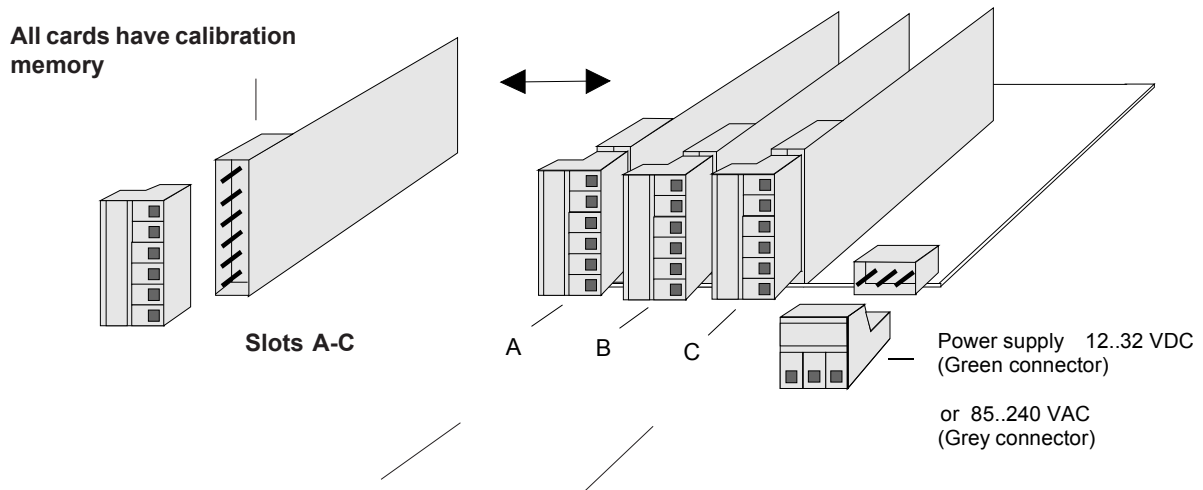

### Change of meter type:

Input card is placed always to slot A. By changing input card you can get an other type of meter. You can change meter with pulse input to meter with current input, thermocouple, strain gage etc.

### Additional slots:

Additional cards provide output 4..20 mA, alarms, serial interface, BCD output etc. Meter data sheet dictates possible combinations. grey connectors allow line voltage 110..240 VAC (relay contacts).

### Power supply:

There are two different mother boards power supply 85..240VAC and 12..32 VDC. mother board accepts 24 VAC. Connectors are colour coded.

# ***Nokeval Oy***

Yrittajakatu 12

37100 NOKIA, FINLAND

Tel. +358 3 342 4800

Fax. +358 3 342 2066

email [support@nokeval.com](mailto:support@nokeval.com)

[http:// www.nokeval.com](http://www.nokeval.com)