

1-phase solid state contactors for resistive loads



Description

The RL Lite slimline series is the ideal solution when multiple solid state relays need to fit in a constrained space. The RL is intended for use with resistive loads.

The **RLC** variants are equipped with an integrated heatsink. The slimmest product, with a 17.8 mm wide footprint, has a rating of 22 AAC @ 40°C. The **RLC** range extends to 30 AAC, which occupies a 22.5 mm wide footprint.

Power terminals are touch protected and allow for easy and safe looping of cables. The removable IP20 covers allow wiring of ring lug terminated cables. The control is provided through a spring pluggable terminal.

The **RLC** output consists of a TRIAC that is protected against overvoltages by means of integrated protection. Control ON indication is provided through a green LED.

Specifications are at a surrounding temperature of 25°C unless otherwise specified.

Benefits

- **Panel space savings.** The RL solid state contactor with a width of only 17.8 mm for ratings up to 22 AAC and 22.5 mm for ratings up to 30 AAC occupies a very small footprint in panels.
- **Trouble free operation over millions of cycles.** Wire bonding technology reduces thermal and mechanical stresses on the output chips resulting in a larger number of fault free operational cycles compared to other assembly technologies.
- **Low machine downtime.** Integrated overvoltage protection prevents the output of the solid state relay from breaking down in case of uncontrolled transients that may occur on the lines.
- **Ready to use.** The RLC is provided with an integrated heatsink, eliminating the need for users to calculate the size of the heatsink required for thermal dissipation and to maintain stock of heatsinks.
- **Touch safe.** The RL output terminals are touch protected. The touch protection cover is removable to allow connection of ring lug terminated cables.
- **Fast wiring.** Spring control terminals help to reduce installation time. The pluggable control terminals allow for fast and easy replacement.
- **Certifications ready.** The RLC conforms to applicable EU directives, UK regulations and is certified by Underwriters Laboratory as a listed product.

Applications

Plastic injection machines, extrusion machines, blow moulding machines, thermoformers, dryers, electrical ovens, fryers, shrink tunnels, climatic chambers, ovens and furnaces, reflow ovens.

Main features

- Voltage ratings up to 530 VAC
- Current ratings up to 22 AAC @ T_A 40°C in a 17.8 mm wide footprint, 30 AAC @ T_A 40°C in a 22.5 mm wide footprint
- DC or AC control voltage
- Integrated overvoltage protection

Order code

 **RLC1A**

Enter the code option instead of . Refer to the selection guide section for valid part numbers.

Code	Option	Description	Comments
RL	-	Solid State Relay - RL series	
C	-	With integrated heatsink	
1	-	1-pole switching	
A	-	Zero Cross switching (ZC)	
<input type="checkbox"/>	40	Rated voltage: 24-440 VAC, 600 Vp	
	48	Rated voltage: 42-530 VAC, 1200 Vp	
<input type="checkbox"/>	D	Control voltage: 4-32 VDC	
	A	Control voltage: 80-250 VAC	
<input type="checkbox"/>	15	Rated current: 15 AAC	17.8 mm wide
	22	Rated current: 22 AAC	17.8 mm wide
	30	Rated current: 30 AAC	22.5 mm wide
<input type="checkbox"/>	-		Single packaging
	X20	Bulk packaging of 20 pcs.	Applicable only to: RLC..15, 22

Selection guide

Rated voltage, Switching mode	Control voltage	Rated operational current @ 40°C		
		15 AAC	22 AAC	30 AAC
400 VAC, ZC	4 - 32 VDC	RLC1A40D15	RLC1A40D22	RLC1A40D30
480 VAC, ZC	4 - 32 VDC	RLC1A48D15	RLC1A48D22	RLC1A48D30
	80 - 250 VAC	RLC1A48A15	RLC1A48A22	RLC1A48A30

Selection guide - Bulk packaging by 20 pcs.

Rated voltage, Switching mode	Control voltage	Rated operational current @ 40°C		
		15 AAC	22 AAC	-
400 VAC, ZC	4 - 32 VDC	RLC1A40D15X20	RLC1A40D22X20	-

Carlo Gavazzi compatible components

Description	Component code	Notes
Control plugs	RGM25	Pack of 10 spring loaded control plugs. 1x control plug is provided with the RL.

Structure

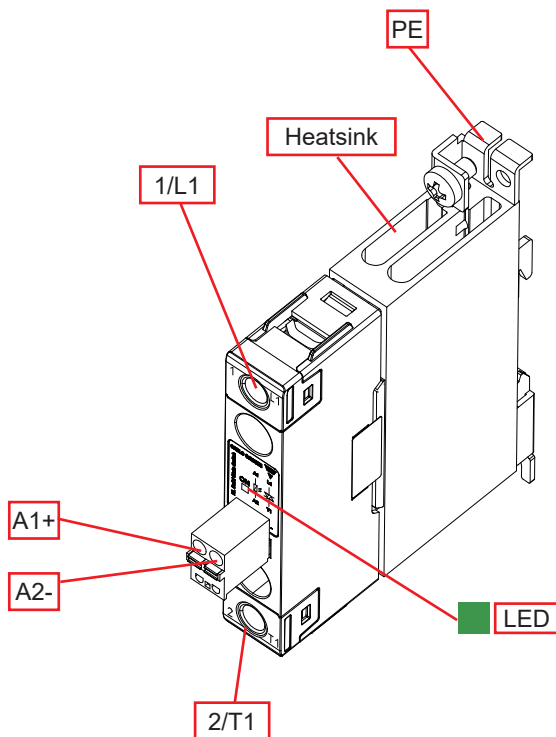

Element	Component	Function
1/L1	Power connection	Mains connection
2/T1	Power connection	Load connection
A1+, A2-	Control connection	Terminals for control voltage
LED	ON indicator	Indicates presence of control voltage
Heatsink	Integrated heatsink	DIN rail mounting (panel mounting also possible)
PE	Protective Earth	Connection for Protective Earth, PE screw not provided with RLC

Features

General data

Material	PA66 or PA6 (UL94 V0), RAL7035 Glow wire ignition temperature and Glow wire flammability index conforming to EN 60335-1 requirements.	
Mounting	DIN rail (panel mount also possible)	
Touch protection	IP20	
Overvoltage category	III, 6 kV (1.2/50 μ s) rated impulse withstand voltage	
Isolation	Input and Output to Case:	4000 Vrms
	Input to Output:	4000 Vrms
Weight (including packaging)	RLC..15, RLC..22:	approx. 267 g
	RLC..30:	approx. 373 g

Performance

Output specifications

	RLC..15	RLC..22	RLC..30
Max. operational current¹: AC-51 @ Ta=25°C	15 AAC	22 AAC	30 AAC
Max. operational current¹: AC-51 @ Ta=40°C	15 AAC	22 AAC	30 AAC
Operational frequency range	45 to 65 Hz		
Output protection	Integrated overvoltage protection		
Leakage current @ rated voltage	<5 mAAC		
Minimum operational current	100 mAAC	150 mAAC	150 mAAC
Repetitive overload current UL508: Ta=40°C, t_{ON}=1 s, t_{OFF}=9 s, 50 cycles	22.5 AAC	33 AAC	45 AAC
Non-repetitive surge current (I_{TSM}), t=10 ms	212 Ap	500 Ap	500 Ap
I²t for fusing (t=10 ms), minimum	225 A ² s	1250 A ² s	1250 A ² s
Power factor	>0.9 at rated voltage		
Critical dV/dt (@Tj init = 40°C)	1000 V/ μ s		

1. Refer to Current derating curves

Output voltage specifications

	RLC..40..	RLC..48..
Operational voltage range	24 - 440 VAC	42 - 530 VAC
Blocking voltage	600 Vp	1200 Vp

Input specifications

	RLC..D..	RLC..A..
Control voltage range ²	4 - 32 VDC	80 - 250 VAC
Pick-up voltage	4.0 VDC	70 VAC
Drop-out voltage	1.2 VDC	10 VAC ³
Maximum reverse voltage	32 VDC	-
Maximum response time	½ mains cycle	52 ms @ 50 Hz
Response time drop-out	½ mains cycle	40 ms @ 50 Hz
Input current @ 40°C	See diagrams below	

- 2. DC control to be supplied by class 2 power source according to UL1310
- 3. RL output is OFF @ 10 VAC but LED may still be ON in the range 4-10 VAC

RL..D.: DC input current vs. input voltage

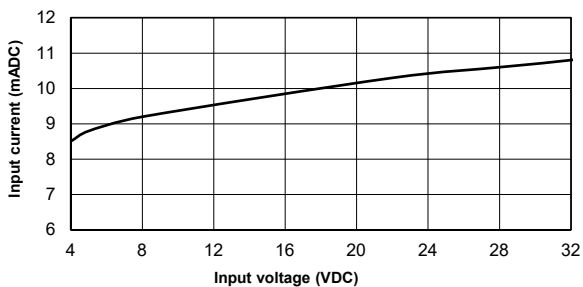

RL..A.: AC input current vs. input voltage

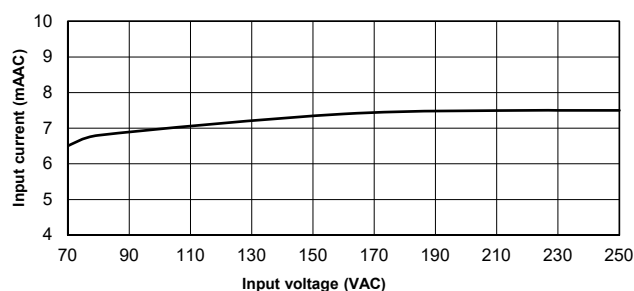

Output power dissipation

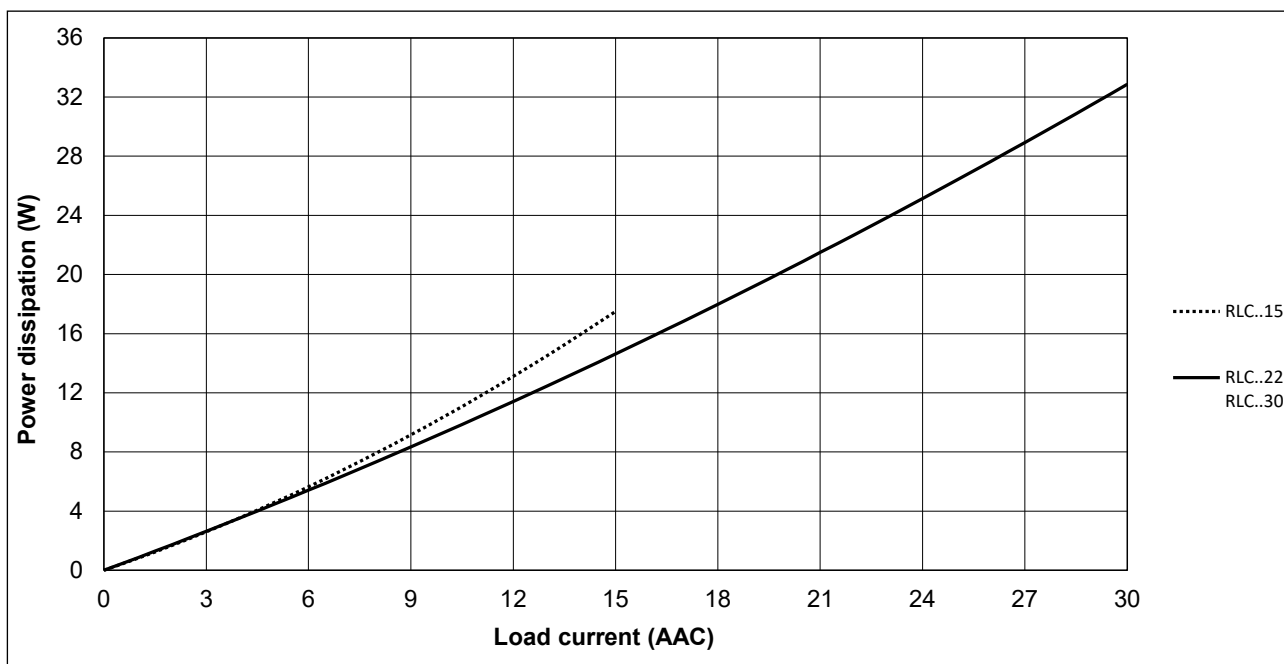

Current derating

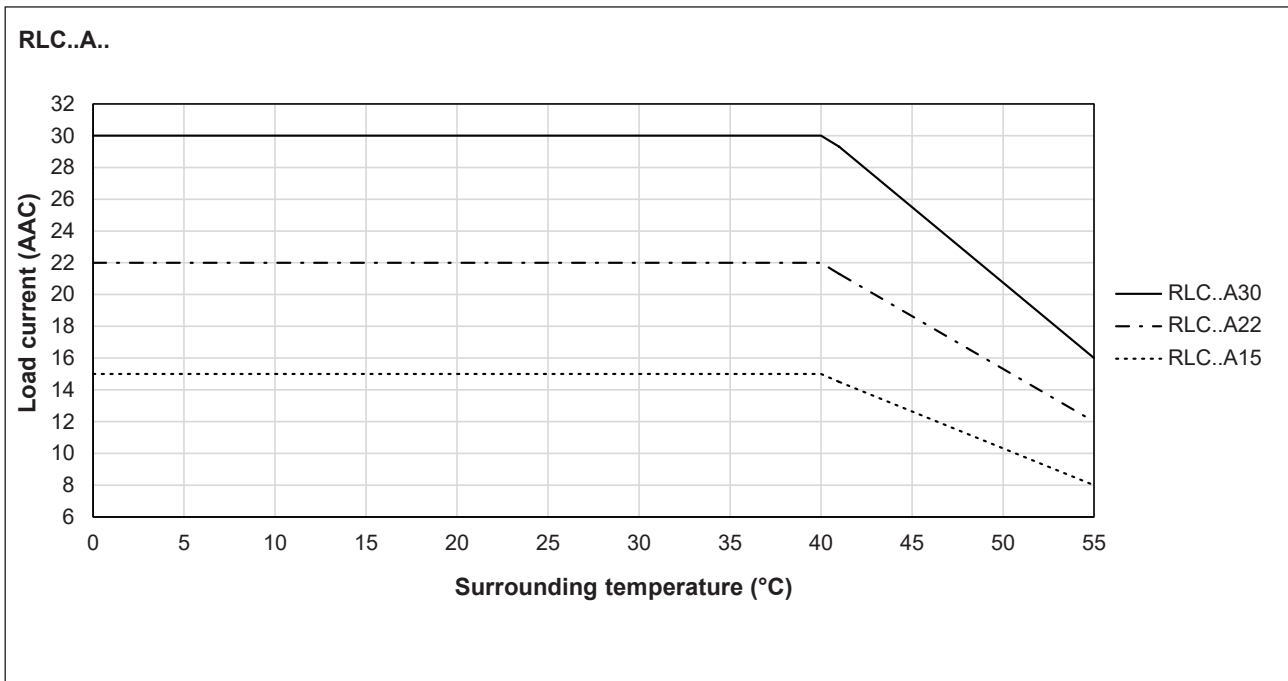
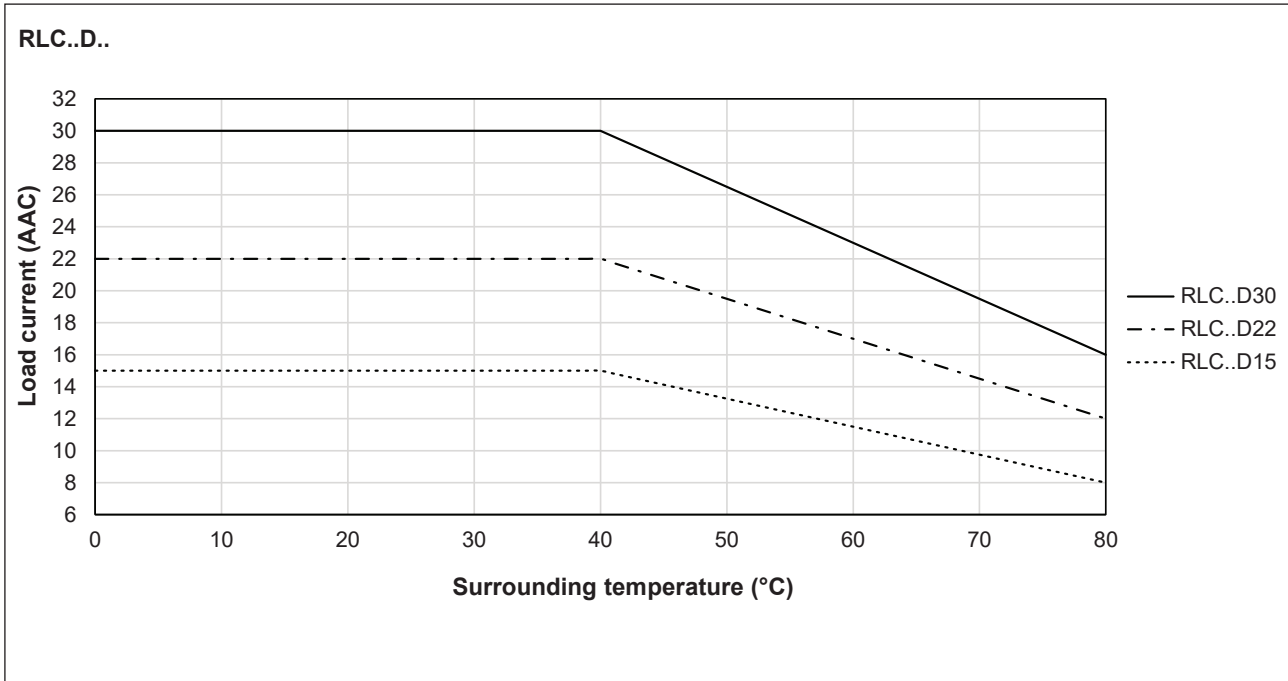

Derating vs. spacing curves

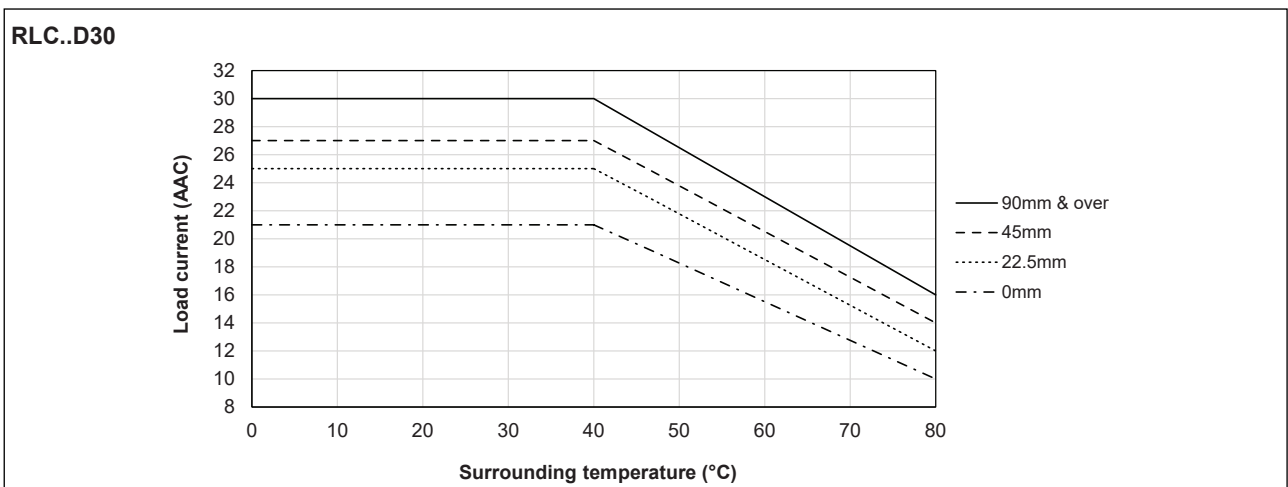
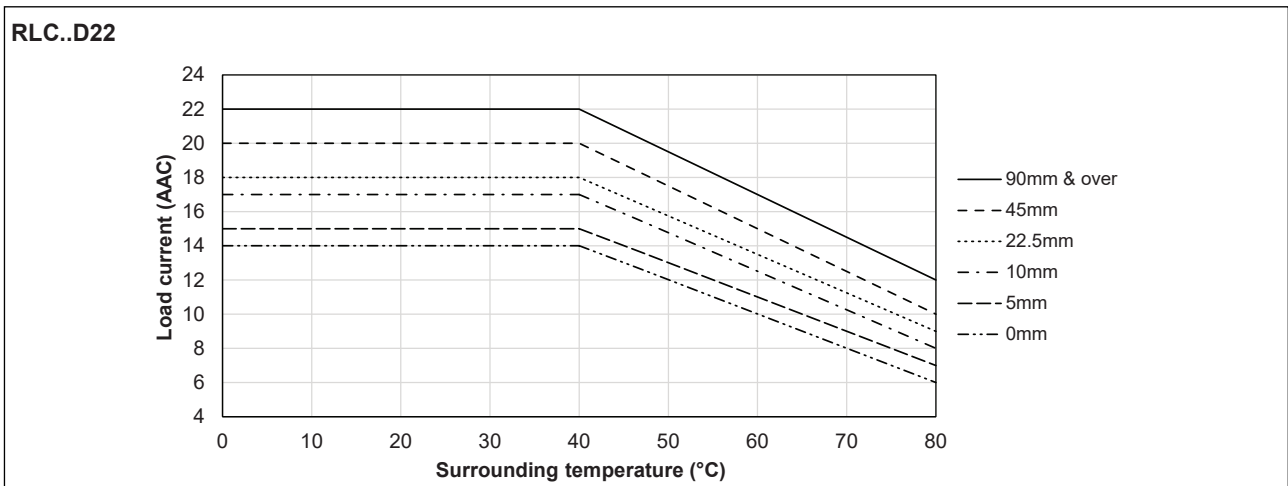
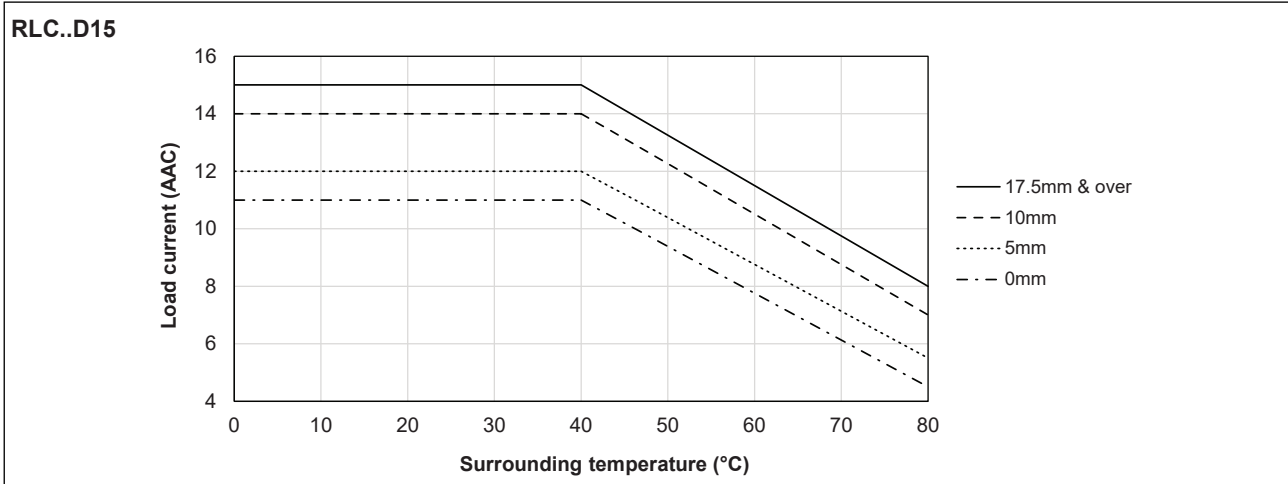

Derating vs. spacing curves (continued)

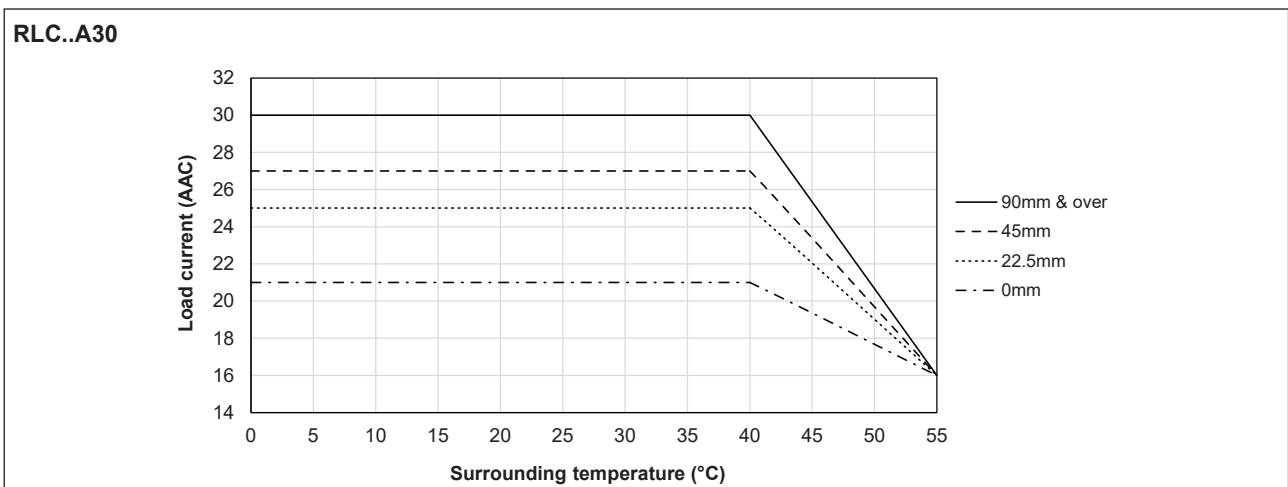
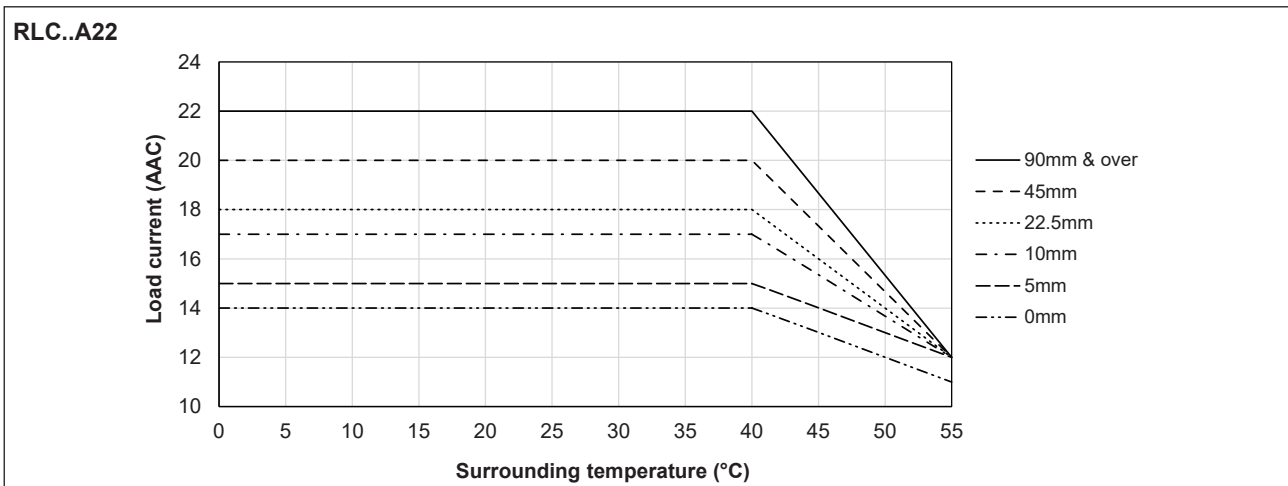
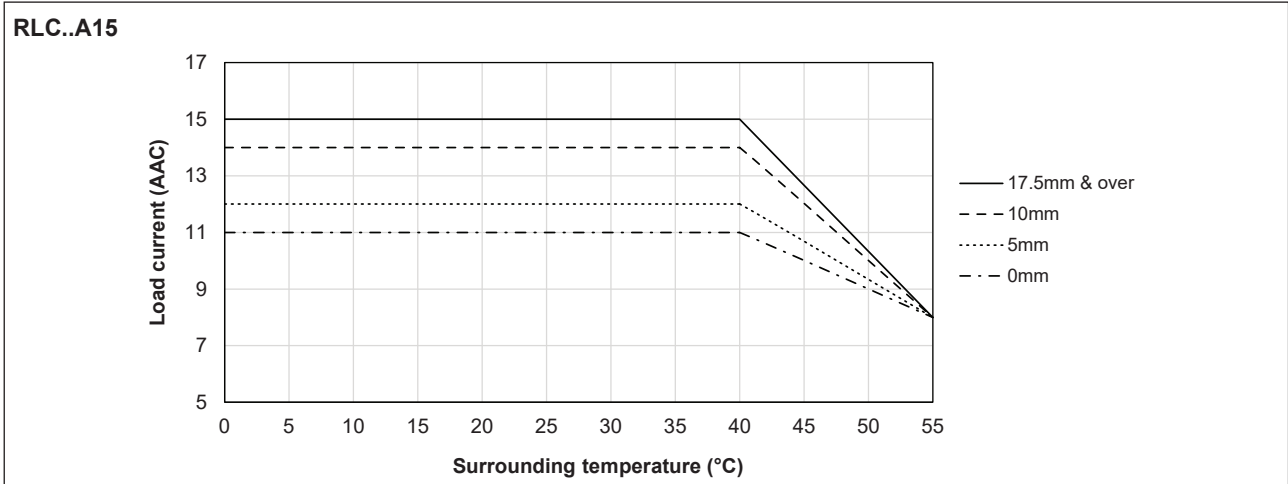

Compatibility and conformance

Approvals	
Standards compliance	LVD: EN 60947-4-3 EMCD: EN 60947-4-3 EE: EN 60947-4-3 EMC: EN 60947-4-3 UL: UL508 (E80573), NRNT cUL: C22.2 No. 14 (E80573), NRNT7

Electromagnetic compatibility (EMC) - Immunity	
Electrostatic discharge (ESD)	EN/IEC 61000-4-2 8 kV air discharge (PC2) 4 kV contact (PC1)
Radiated radio frequency	EN/IEC 61000-4-3 10 V/m, from 80 MHz to 1 GHz (PC1) 10 V/m, from 1.4 to 2 GHz (PC1) 10 V/m, from 2 to 2.7 GHz (PC1)
Electrical fast transient (burst)	EN/IEC 61000-4-4 Output: 2 kV, 5 kHz (PC2) Input: 1 kV, 5 kHz (PC1)
Conducted radio frequency	EN/IEC 61000-4-6 10 V/m, from 0.15 to 80 MHz (PC1)
Electrical surge	EN/IEC 61000-4-5 Output, line to line: 1 kV (PC2) Output, line to earth: 2 kV (PC2) Input, line to line, 1 kV (PC2) Input, line to earth, 2 kV (PC2)
Voltage dips	EN/IEC 61000-4-11 0% for 0.5, 1 cycle (PC2) 40% for 10 cycles (PC2) 70% for 25 cycles (PC2) 80% for 250 cycles (PC2)
Voltage interruptions	EN/IEC 61000-4-11 0% for 5000 ms (PC2)

Electromagnetic compatibility (EMC) - Emissions	
Radio interference field emission (radiated)	EN/IEC 55011 Class A: from 30 to 1000 MHz
Radio interference voltage emissions (conducted)	EN/IEC 55011 Class A: from 0.15 to 30 MHz (External filter may be required - refer to Filtering section)

Notes:

- Control input lines must be installed together to maintain products' susceptibility to Radio Frequency interference.
- Use of AC solid state relays may, according to the application and the load current, cause conducted radio interferences. Use of mains filters may be necessary for cases where the user must meet E.M.C requirements. The capacitor values given inside the filtering specification tables should be taken only as indications, the filter attenuation will depend on the final application.
- This product has been designed for Class A equipment. Use of this product in domestic environments may cause radio interference, in which case the user may be required to employ additional mitigation methods.
- Performance Criteria 1 (PC1): No degradation of performance or loss of function is allowed when the product is operated as intended.
- Performance Criteria 2 (PC2): During the test, degradation of performance or partial loss of function is allowed. However when the test is complete the product should return operating as intended by itself.
- Performance Criteria 3 (PC3): Temporary loss of function is allowed, provided the function can be restored by manual operation of the controls.

Filtering

Part number	Suggested filter for EN 55011 Class A compliance	Maximum heater current [AAC]
RLC..15	68 nF / xx V / X1	15 AAC
RLC..22	220 nF / xx V / X1	22 AAC
RLC..30	220 nF / xxV / X1	30 AAC

xx represents the voltage rating of the capacitor. This shall not be lower than the mains supply voltage to which it will be connected.

Filter connection diagram

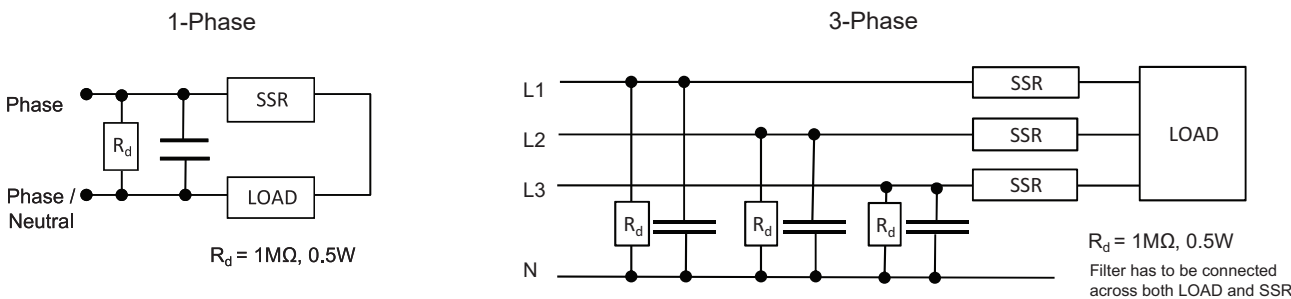

Short circuit protection, co-ordination type 2

Part No.	Prospective short circuit current [kArms]	Ferraz Shawmut (Mersen)		Siba	
		Max fuse size [A]	Part number	Max fuse size [A]	Part number
RLC..15	10	20	6.921 CP GR 22x58 /20 FR22GR69V20T	20	50 124 06.20
RLC..22	10	40	6.921 CP GR 22x58 /40 FR22GR69V40T	40	50 124 06.40
RLC..30					

Environmental specifications

Operating temperature	-30°C to +80°C (-22°F to +176°F) max. +55°C (+131°F) for RL..A..
Storage temperature	-40°C to +100°C (-40°F to +212°F)
Relative humidity	95% non-condensing @ 40°C
Pollution degree	2
Installation altitude	0-1000 m. Above 1000 m derate linearly by 1% of FLC per 100 m up to a maximum of 2000 m
Vibration resistance	2g / axis (2-100Hz, IEC 60068-2-6, EN 50155, EN 61373)
Impact resistance	15/11 g/ms (EN50155, EN61373)
EU RoHS compliant	Yes
China RoHS	

The declaration in this section is prepared in compliance with People's Republic of China Electronic Industry Standard SJ/T11364-2014: Marking for the Restricted Use of Hazardous Substances in Electronic and Electrical Products.

Part Name	Toxic or Harardous Substances and Elements					
	Lead (Pb)	Mercury (Hg)	Cadmium (Cd)	Hexavalent Chromium (Cr(VI))	Polybrominated biphenyls (PBB)	Polybrominated diphenyl ethers (PBDE)
Power Unit Assembly	x	o	o	o	o	o

O: Indicates that said hazardous substance contained in homogeneous materials fot this part are below the limit requirement of GB/T 26572.

X: Indicates that said hazardous substance contained in one of the homogeneous materials used for this part is above the limit requirement of GB/T 26572.

这份申明根据中华人民共和国电子工业标准 SJ/T11364-2014：标注在电子电气产品中限定使用的有害物质

零件名称	有毒或有害物质与元素					
	铅 (Pb)	汞 (Hg)	镉 (Cd)	六价铬 (Cr(VI))	多溴化联苯 (PBB)	多溴联苯醚 (PBDE)
功率单元	x	o	o	o	o	o

O:此零件所有材料中含有的该有害物低于GB/T 26572的限定。

X: 此零件某种材料中含有的该有害物高于GB/T 26572的限定。

Dimensions

RLC..15, RLC..22

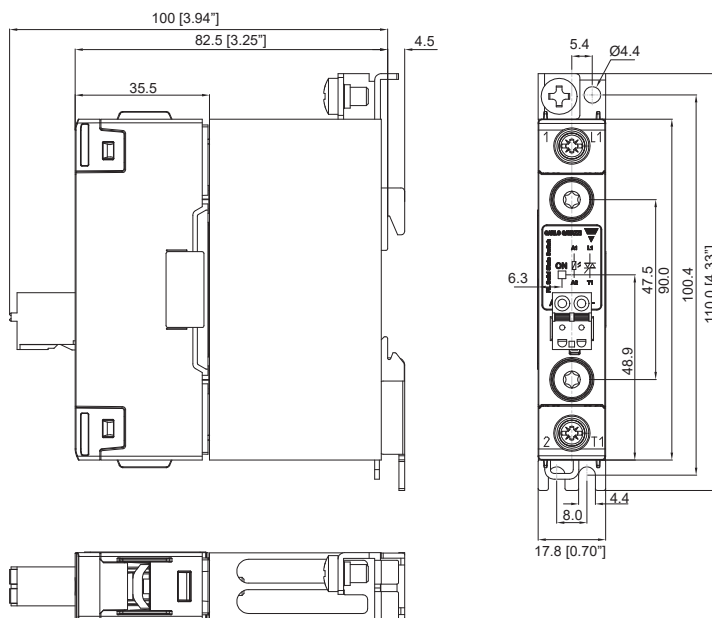

RLC..30

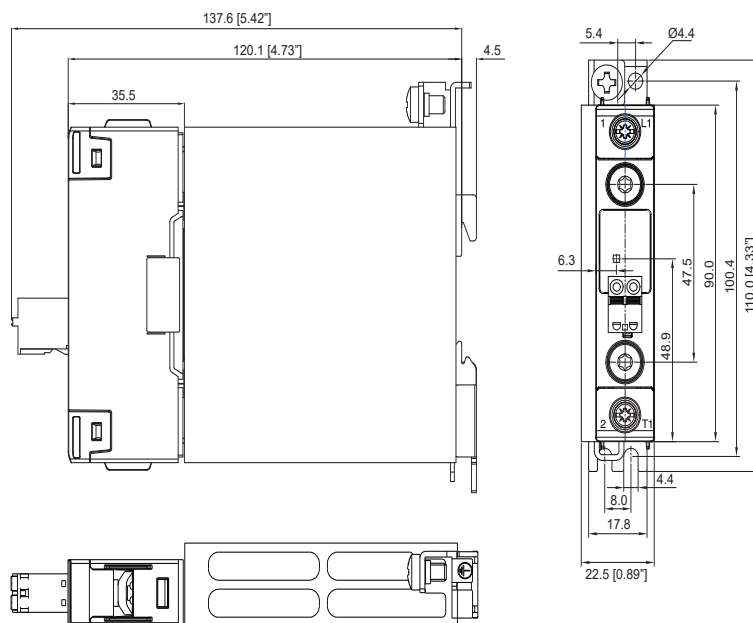

Housing width tolerance +0.5mm, -0mm as per DIN 43880. All other tolerances +/- 0.5mm.
Dimensions in mm.

Terminal layout

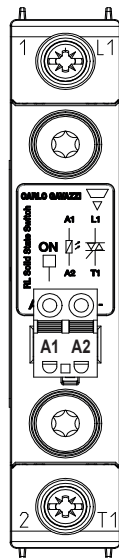

1/L1: Mains supply connection
 2/T1: Load connection
 A1(+): Positive control signal
 A2(-): Control ground
 ⊕ : Protective earth

Connection diagram

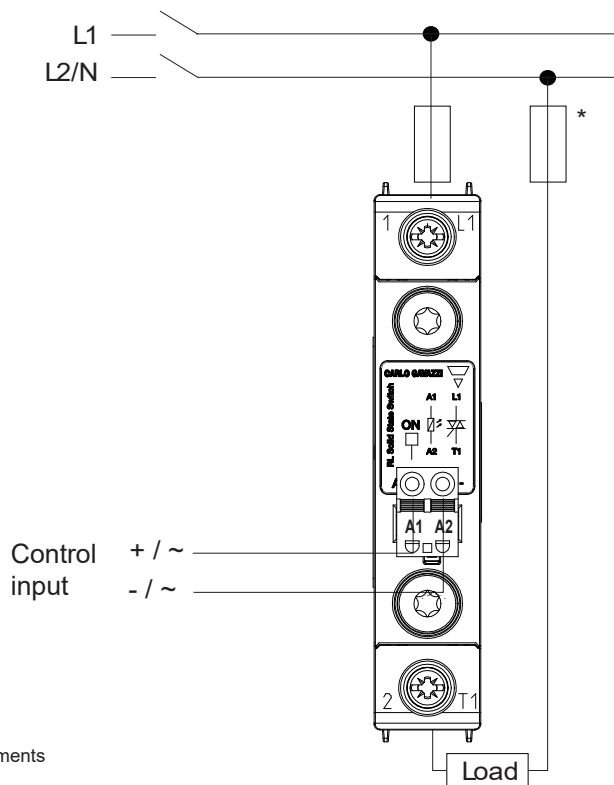

* depends on system requirements

Functional diagram

DC control

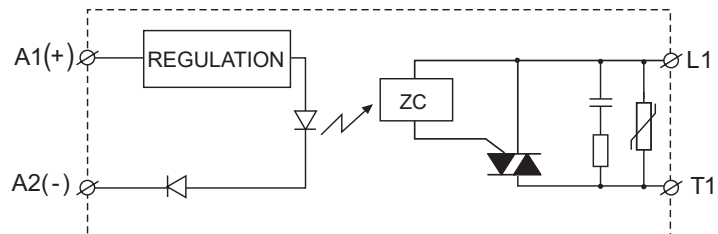

AC control

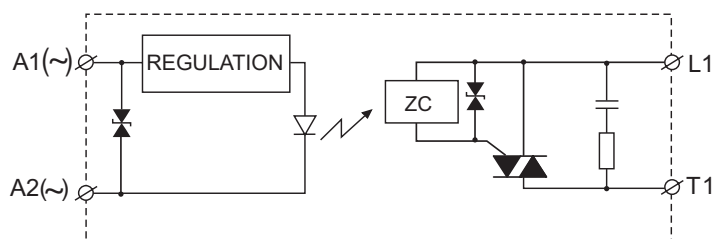

Installation

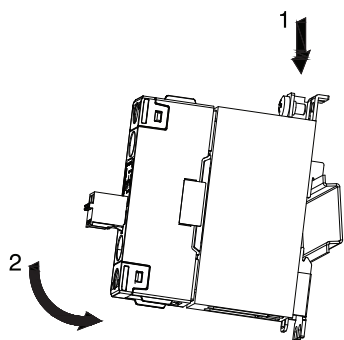



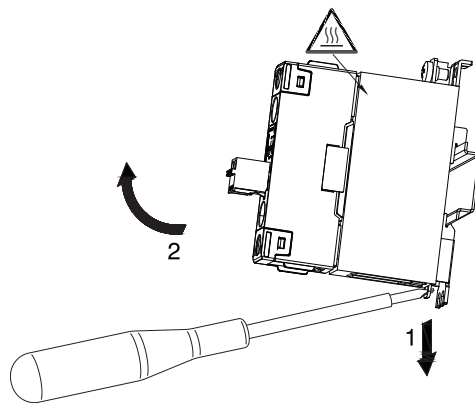

Mounting on DIN rail

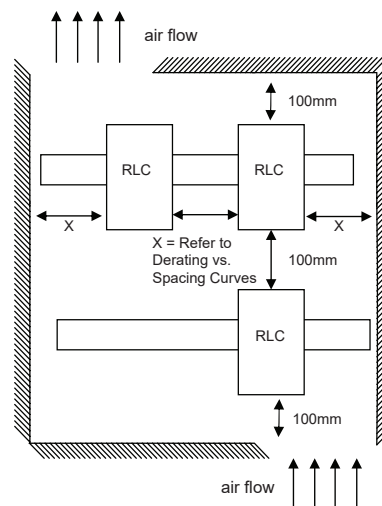

Dismounting from DIN rail

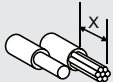

Connection specifications

Power connections			
Terminals	1/L1, 2/T1		
Conductors	Use 75°C copper (Cu) conductors		
			
Connection type	M4 screw with captivated washer		
Stripping length	X = 12 mm		
Rigid (solid & stranded) UL/cUL rated data	 <table border="1" style="width: 100%; border-collapse: collapse;"> <tr> <td style="width: 50%;">2x 2.5 – 6.0 mm² 2x 14 – 10 AWG</td> <td style="width: 50%;">1x 2.5 – 6.0 mm² 1x 14 – 10 AWG</td> </tr> </table>	2x 2.5 – 6.0 mm ² 2x 14 – 10 AWG	1x 2.5 – 6.0 mm ² 1x 14 – 10 AWG
2x 2.5 – 6.0 mm ² 2x 14 – 10 AWG	1x 2.5 – 6.0 mm ² 1x 14 – 10 AWG		
Flexible with end sleeve	 <table border="1" style="width: 100%; border-collapse: collapse;"> <tr> <td style="width: 50%;">2x 1.0 – 2.5 mm² 2x 2.5 – 4.0 mm² 2x 18 – 14 AWG 2x 14 – 12 AWG</td> <td style="width: 50%;">1x 1.0 – 4.0 mm² 1x 18 – 12 AWG</td> </tr> </table>	2x 1.0 – 2.5 mm ² 2x 2.5 – 4.0 mm ² 2x 18 – 14 AWG 2x 14 – 12 AWG	1x 1.0 – 4.0 mm ² 1x 18 – 12 AWG
2x 1.0 – 2.5 mm ² 2x 2.5 – 4.0 mm ² 2x 18 – 14 AWG 2x 14 – 12 AWG	1x 1.0 – 4.0 mm ² 1x 18 – 12 AWG		
Flexible without end sleeve	 <table border="1" style="width: 100%; border-collapse: collapse;"> <tr> <td style="width: 50%;">2x 1.0 – 2.5 mm² 2x 2.5 – 6.0 mm² 2x 18 – 14 AWG 2x 14 – 10 AWG</td> <td style="width: 50%;">1x 1.0 – 6.0mm² 1x 18 – 10 AWG</td> </tr> </table>	2x 1.0 – 2.5 mm ² 2x 2.5 – 6.0 mm ² 2x 18 – 14 AWG 2x 14 – 10 AWG	1x 1.0 – 6.0mm ² 1x 18 – 10 AWG
2x 1.0 – 2.5 mm ² 2x 2.5 – 6.0 mm ² 2x 18 – 14 AWG 2x 14 – 10 AWG	1x 1.0 – 6.0mm ² 1x 18 – 10 AWG		
Torque specifications	 <p>Posidrive bit 2 UL: 2.0 Nm (17.7 lb-in) IEC: 1.5 – 2.0 Nm (13.3 – 17.7 lb-in)</p>		
Aperture for termination lug (fork or ring)	12.3 mm		
Protective Earth (PE) connection	M5, 1.5 Nm (13.3 lb-in) M5 PE screw is not provided with the solid state relay. PE connection is required when product is intended to be used in Class 1 applications according to EN/IEC 61140.		

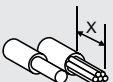
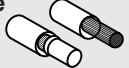
Control connections			
Terminals	A1+, A2-		
Conductors	Use 60/75°C copper (Cu) conductors		
			
Connection type	Spring loaded		
Stripping length	X = 12-13 mm		
Rigid (solid & stranded) UL/cUL rated data	 <table border="1" style="width: 100%; border-collapse: collapse;"> <tr> <td style="width: 50%;">1x 0.2 - 2.5 mm² 1x 24 - 12 AWG</td> <td style="width: 50%;"></td> </tr> </table>	1x 0.2 - 2.5 mm ² 1x 24 - 12 AWG	
1x 0.2 - 2.5 mm ² 1x 24 - 12 AWG			
Flexible with or without end sleeve	 <table border="1" style="width: 100%; border-collapse: collapse;"> <tr> <td style="width: 50%;">1x 0.2 - 2.5 mm² 1x 24 - 12 AWG</td> <td style="width: 50%;"></td> </tr> </table>	1x 0.2 - 2.5 mm ² 1x 24 - 12 AWG	
1x 0.2 - 2.5 mm ² 1x 24 - 12 AWG			
Flexible with end sleeve using TWIN ferrules	2x 0.2 - 1.0 mm ² 2x 24 - 18 AWG		

Bulk packaging option



- Packing quantity: 20 pcs.
- Total weight (including packaging): 4.8 kg

Applicable only to RLC..15 and RLC..22 variants.



COPYRIGHT ©2022.
Content subject to change.
Download the PDF: <https://gavazziautomation.com>