

**ABSOLUTE  
ENCODER  
759UMA**

Programmable absolute single/multiturn encoder with up to 65536 steps x4096 rev  
 With SSI interface and incremental output: 1024 sin/cos or up to 16384 line driver  
 With blind hollow shaft up to Ø 15mm passing with a spring coupling.  
 Fixing on the motor shaft by means of grub-screws

Family: **A**  
 pag.: 01.759CMA 1/2  
 data sheet IG 011 X0B

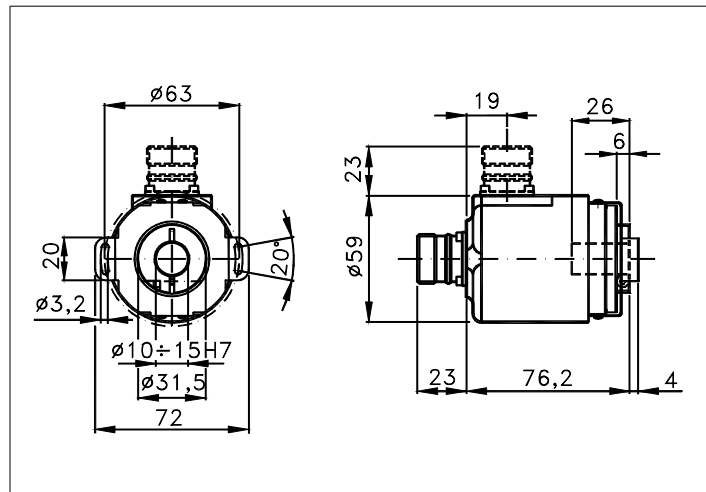

Measures without tolerance according to UNI ISO 2768-mk

**TECHNICAL FEATURES AND POSSIBLE CONFIGURATIONS**

- Output codes.....: Gray or Binary
- Max resolution ...: 65536 (16 bit)
- Max revolutions ...: 4096 rev.(12 bit)
- Power supply Vcc....: 10÷30 V
- Max consumption.....: 200 mA
- Optical sensors.....: OptoAsic
- Operating temp.....: -20 ÷ +85 °C
- Storage temp.....: -30 ÷ +85 °C
- Max. clock freq.....: 500 kHz
- Inputs.....: SSI Clock, DIR, PRESET
- Output electronic....: Line driver RS 422
- Interface .....: (S1) SSI with Preset
- Options .....: (PR) Programmable  
(S) Sin/Cos 1024  
(I) Incremental

(\*)

- Connect. (R) Radial : CV CL SL CH  
(-) Axial CV CL SL CH
  - Base.....: Aluminium
  - Cover.....: VALOX 420
  - Weight.....: 340 g
  - Shaft.....: Cava acc. inox Ø 6÷15
  - Max.rad/ax.load....: 4 Kg
  - IP output side.....: see 'CONNECTIONS'pag. 2
  - IP shaft side.....: std.64 | sealed 66
  - Contin. max RPM(°): 6000 | 3000
  - Starting torq. gcm.: 60 | 90
  - Impact resistance...: 50 G (11 ms)
  - Vibration resist....: 12 G (10 ÷ 2000 Hz)
  - MTTFd (°).....: HIGH
- (°)MTTFd according to UNI EN ISO 13849-1  
 (\*\*) Intermittent max RPM + 30% of continuous max RP

**PROGRAMMABLE PARAMETERS**

Programming (PR option) is available with SW on PC connected by special cable to a USB that feeds the encoder. It can be also provided a RS422 interface that allows to program and exchange data in ASCII code with the encoder.(SW and cable are supplied upon request)

**Programmable parameter:**

- Code.....: Gray or Binary
- Resolution...: Max encoder physical resolution
- Preset.....: Preset value
- Direction...: Counting direction

**POSSIBLE OPTIONS**

CODE	DESCRIPTION	CODE	DESCRIPTION	CODE	DESCRIPTION
Y	Unbreakable disk	X	Custom options	G	Tropicalization
		P	Compressed air connect	Z	Sealed ball bearing



Elcis encoder s.r.l. Via Rosa Luxembourg 12/14 10093 COLLEGNO (TO) ITALY  
 Phone: +39 011 715577/78 r.a.  
 MAIL: Elcis encoder s.r.l. P.O.Box 70 10093 COLLEGNO (TO) ITALY

\* <http://www.elcis.com>  
 \* e-mail: [info@elcis.com](mailto:info@elcis.com)  
 \* Fax: +39 011 712613

## SSI INTERFACE

### SSI INTERFACE DESCRIPTION.

Position value is transmitted in synchronous mode with Clock signal, provided by control, starting from the MSB. At the beginning of a reading sequence, the first leading front of Clock stores position data in a Shift-Register, with the next rise fronts of the Clock it occurs the transmission starting from (MSB) bit. On the rise front of last Clock starts a mono-stable that keeps down the data line for a time  $t_p \sim 32 \mu s$ , during this time it is not possible to send another pulses sequence.

The Clock pulses sequence is:

-14 pulses for singleturn encoder with max 13 bit (8192) resolution

-26 pulses for multiturn encoder with max 25 bit (8192 x 4096 rev) resolution

-29 pulses for multiturn encoder with max 28 bit (65536 x 4096 rev) resolution

The position bit is always right aligned, therefore, if the resolution is less than the max. resolution, the lacking MSB are at 0.

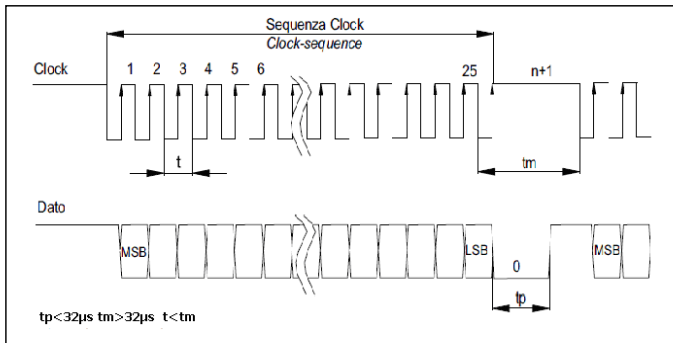

CONNECTIONS			
SIGNAL	CABLE	CONNECTOR	
		CH	CL - SL
DATA+	WHITE	3	B
DATA-	BROWN	4	H
CLOCK+	YELLOW	2	A
CLOCK-	ORANGE	1	G
DIR	VIOLET	8	I
PRESET	GREEN	9	C
PROG	BLACK	7	J
+Vprog	GRAY	10	E
+Vcc	RED	11	D
0V - GND	BLUE	12	F

CONNECTIONS Opz. S / I		
SIGNAL	CABLE	CONNECTOR
		CH
DATA+	WHITE	3
DATA-	BROWN	4
CLOCK+	YELLOW	2
CLOCK-	ORANGE	1
DIR	VIOLET	8
PRESET	GREEN	9
Sin+/A+	W./BLACK	5
Sin-/A-	W./BROWN	6
Cos+/B+	BLACK	7
Cos-/B-	GREY	10
+Vcc	RED	11
0V - GND	BLUE	12

## ORDERING CODE

Possible noril bug 0

( n ) 0 n a rich.  
( 6 ) 0 6  
( 8 ) 0 8  
( 10 ) 0 10  
( 12 ) 0 12  
( 15 ) 0 15

(G) Gray  
(B) Binary

( CV ) 1 m long cable  
( CL )  
( SL )  
( CH )  
( )

IP65

(S1) SSI with Preset

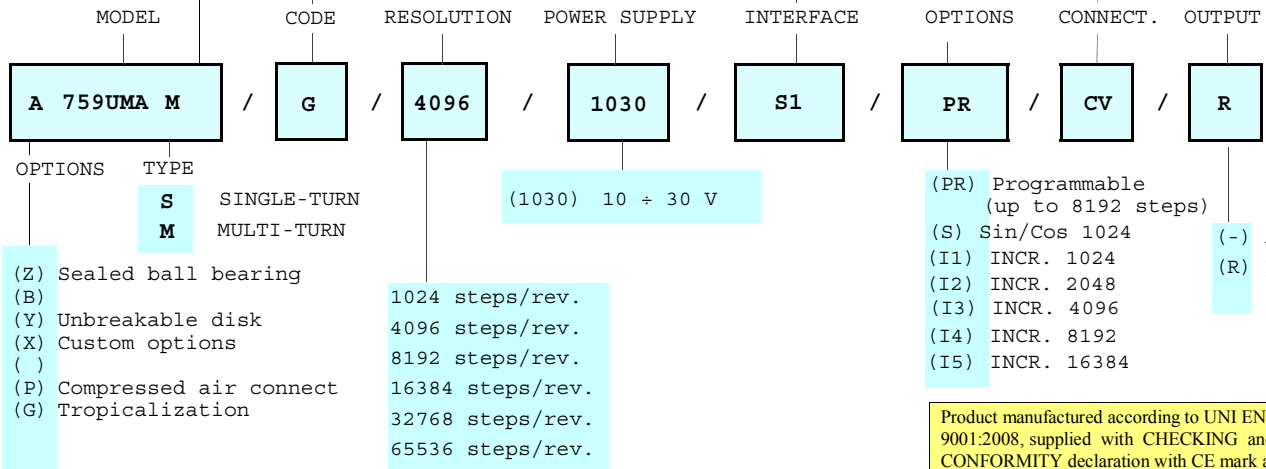

Product manufactured according to UNI EN ISO 9001:2008, supplied with CHECKING and CONFORMITY declaration with CE mark and with TWO (2) YEARS WARRANTY starting from delivery date.

ELCIS company has the right to make any changing without previous notice.

data sheet IG 011 X0B pag.: 01. 759CMA 2/2



Elcís encoder s.r.l. Via Rosa Luxembourg 12/14 10093 COLLEGNO (TO) ITALY  
 Phone: +39 011 715577/78 r.a.  
 MAIL: Elcís encoder s.r.l. P.O.Box 70 10093 COLLEGNO (TO) ITALY

\* <http://www.elcis.com>  
 \* e-mail: [info@elcis.com](mailto:info@elcis.com)  
 \* Fax: +39 011 712613