

ORDERING INFORMATION

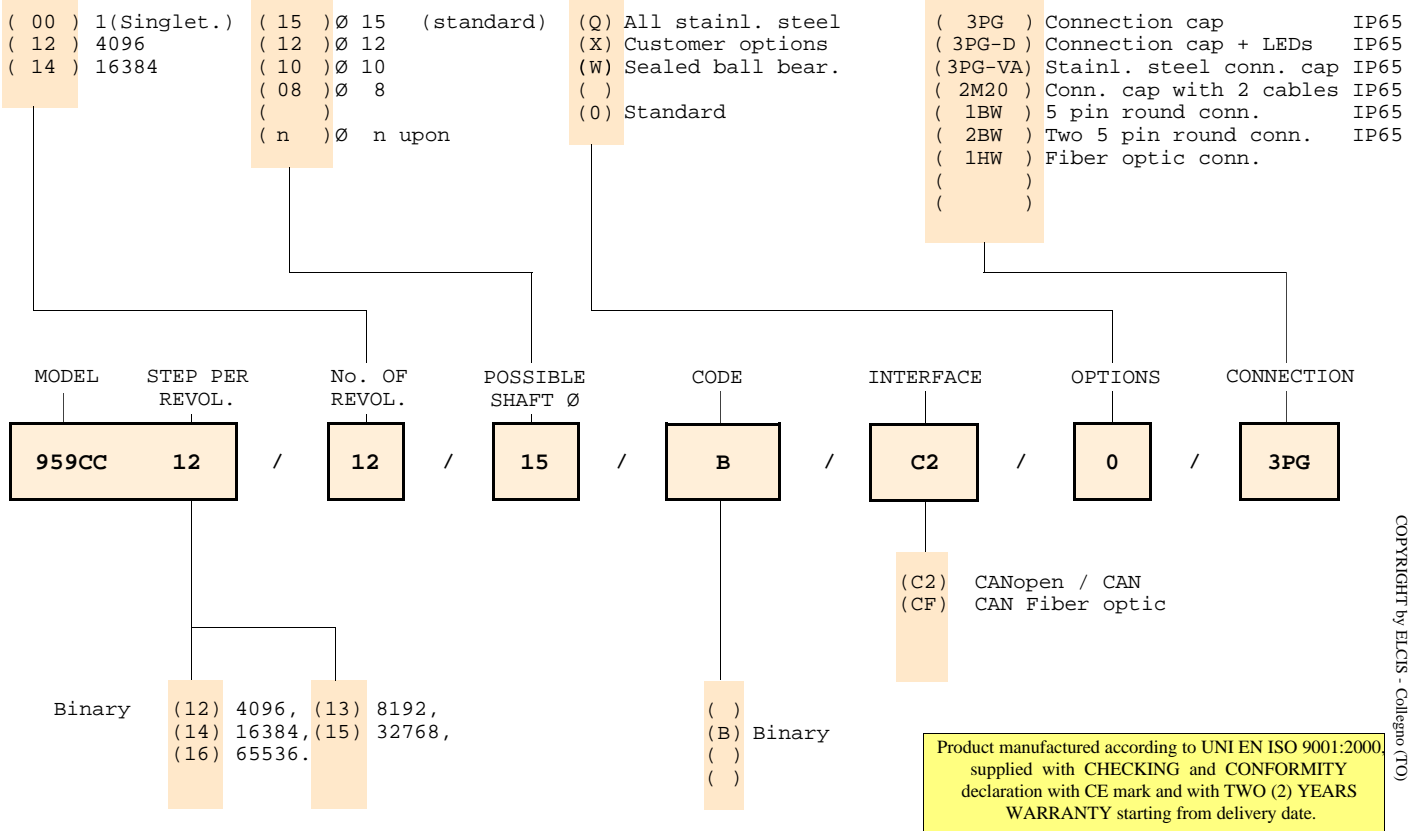

COPYRIGHT by ELCIS - Collegno (TO)

ELCIS company has the right to make any changins without previous notice.

data sheet IB 037 E00 page: 08.959CC 2/2

 ELCIS s.r.l. Via Rosa Luxembourg 12/14 10093 COLLEGNO (TO) ITALY
 Phone: +39 011 715577/78 r.a.
 MAIL: ELCIS s.r.l. P.O.Box 90 10093 COLLEGNO (TO) ITALY

 * http://www.elcis.com
 * e-mail: info@elcis.com
 * Fax: +39 011 712613