

# Technical Datasheet



## SRZ KL Series

### Helical Flow Meters

for high-viscosity, non abrasive and lubricating fluids

## Overview

With more than 50 years of experience in the flow measurement field and numerous innovative and customer-specific product developments, we are a qualified and competent contact for flow measuring technology and calibration. KEM offers a broad selection of measuring principles for this purpose. We develop, produce, and deliver high quality Gear Flow Meters, Turbine Flow Meters, Helical Flow Meters and Micro Flow Meters as well as Coriolis Mass Flow Meters worldwide. Specific accessories complement the product range.

This document provides information, technical details and typical applications concerning the SRZ KL Helical Flow Meter Series.

Series	Application	Process Medium	Attributes
SRZ ST	Flow measurement	Polymers, adhesives, silicone Abrasive, less lubricating Medium/high viscosity	Stainless steel body Tungsten carbide sleeve bearing Bigger tolerances
SRZ KL	Filling processes	Hydraulic fluids, glycol, grease Lubricating Medium/high viscosity	Stainless steel body Stainless steel ball bearing Bigger tolerances
SRZ Compact	Consumption measurement	Sealant, additives, fuels Abrasive, less lubricating Medium/high viscosity	Stainless steel body Tungsten carbide sleeve bearing Bigger tolerances
SRZ High Resolution	Dosage control (High Resolution)	Resin, lubricants, waxes Abrasive, less lubricating Medium/high viscosity	Stainless steel body Tungsten carbide sleeve bearing Bigger tolerances

Please contact KEM Sales for additional information on our Flow Meters or for advisory purposes related to your individual application needs. For KEM Sales contact details see the document's last page.



## Description

The SRZ KL helical flow meter series (ball bearing design) are used mainly in highly viscous, not abrasive as well as lubrication media.

Intended for precise volume flow measurement in various media. These include a variety of oils and fuels, greases and lubricants of all kinds, and also coolants and test fluids. The innovative design is particularly well suited for use in test stands. Different viscosities due to temperature fluctuations only have a minor effect on the measurement accuracy.

Furthermore, the helical flow meter sets itself apart with a broad measuring range and low pressure loss. Thanks to the ball bearings, the reproducible detection of the smallest volume flows is possible even at low viscosity.

Only high-grade steels that even withstand corrosive liquids are used in the production of helical flow meters. Combined with the use of stainless steel precision ball bearings, the SRZ KL guarantees optimum measurement accuracy and a long service life even under the toughest application conditions.

Short response times, very dynamic performance and high measurement accuracy ensure accurate regulation and control of flow rates in demanding applications.

For applications in hazardous areas, we offer intrinsically safe sensors and amplifiers with Ex protection in accordance with ATEX, IECEx, CSA and other standards. Additional certifications such as EAC (TR-CU) are available.

## Principle and Design

Two cycloidal helical spindles with geometrically lapped profiles that interlock with high precision lie in a cylindrical housing. This creates enclosed measuring chambers between the spindle profiles and the wall of the housing. These transport the medium being measured.

The medium is forcibly guided and flows through the measuring chamber bores in the axial direction, causing the spindles to rotate. This process is pulsation-free with minimum leakage. A contactless frequency measuring element with a high-speed pulse wheel captures the rotational speed of the spindle pair through the housing wall. The rotational speed of the spindles is exactly proportional to the volume flow over a very wide range. Impulses per unit of volume are available for the analysis.

The calibration factor of the Helical Flow Meter describes the exact pulse rate per unit of volume. In order to determine the individual calibration factor of a flow meter, each of our meters is internally calibrated by us prior to delivery. The operating viscosity specified by the customer is taken into account for calibration. A corresponding calibration certificate is included with every flow meter we supply.

## Applications

- Hydraulic and gear oils
- Fats and waxes
- Water/glycol mixtures
- Light to heavy fuel oil
- All sorts of fuels
- Thixotropic liquids

## Features

- High measuring accuracy up to  $\pm 0.1\%$ <sup>1)</sup>
- Exceptional repeatability of  $\pm 0.05\%$
- Measuring range up to 1:100
- Short response times
- Pressure-resistant up to 315 bar [4,500 psi]
- Argely independent of viscosity, perfect for 1 to  $1 \times 10^6$  mm<sup>2</sup>/s
- Low pressure drop compared with other positive displacement meters
- High resolution
- Pulsation-free measurement, non-sensitive to pulsating flows
- Resistant to corrosion by advanced materials and bearings

<sup>1)</sup> Under laboratory conditions; incl. linearization; viscosity  $\geq 30$  mm<sup>2</sup>/s.

### Technical Data – Sizes

SRZ Type <sup>2)</sup>	Measuring Range (l/min)		K-Factor <sup>3)</sup> (pulses/l)	max. Pressure (bar/psi)		Frequency <sup>3)</sup> (Hz)			Weight (kg)
				Bolts ISO 4762	Bolts A4-70				
SRZ 40	0.4	to 40	3,500	315 [4,500]	250 [3,600]	20	to	2,350	6.2
SRZ 100	1.0	to 100	850	250 [3,600]	250 [3,600]	14	to	1,450	15.0
SRZ 400	4.0	to 400	214	200 [2,900]	200 [2,900]	14	to	1,450	34.0

### Technical Data – General

Measuring Accuracy	Up to $\pm 0.1$ % <sup>4)</sup>
Repeatability	$\pm 0.05$ % (under the same conditions)
Linearity	$\pm 0.5$ % of actual flow (viscosity $\geq 30$ mm <sup>2</sup> /s) $\pm 0.25$ % of actual flow (viscosity $\geq 100$ mm <sup>2</sup> /s)
Materials	Housing: as per DIN 1.4305 [AISI 303], 1.4404 [AISI 316L] Helicals: as per DIN 1.4122 Bearing: Stainless steel ball bearing Seals: FKM, PTFE (others on request)
Medium Temperature	-40 °C up to +180 °C [-40 °F up to +356 °F] (others on request)
Dimensions	See dimensional drawing (page 5)

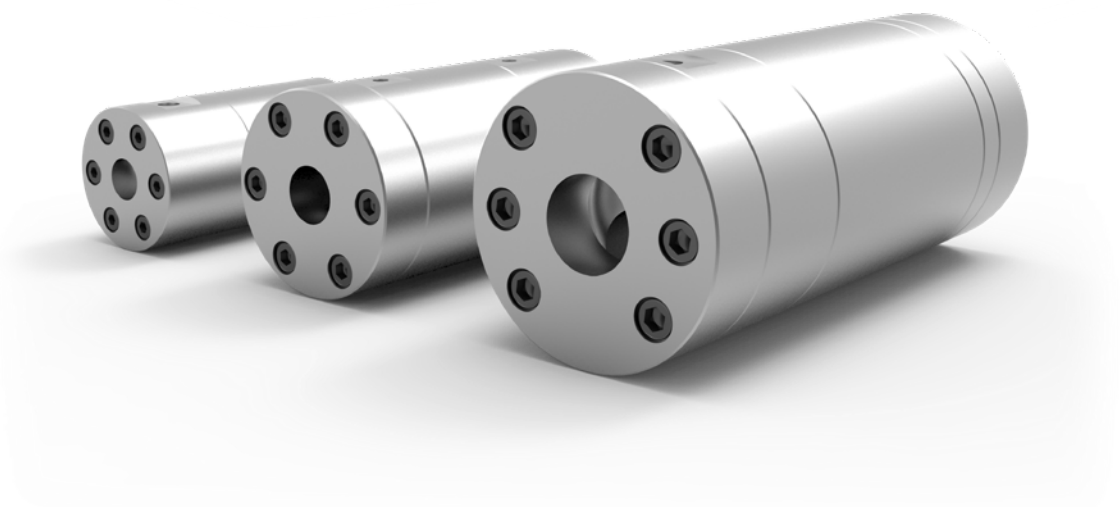

<sup>2)</sup> Exact type designation see ordering code (page 6).

<sup>3)</sup> Average values for single sensors, dual pickups and higher resolution available.

<sup>4)</sup> Under laboratory conditions; incl. linearization; viscosity  $\geq 30$  mm<sup>2</sup>/s.

Dimensional Drawing

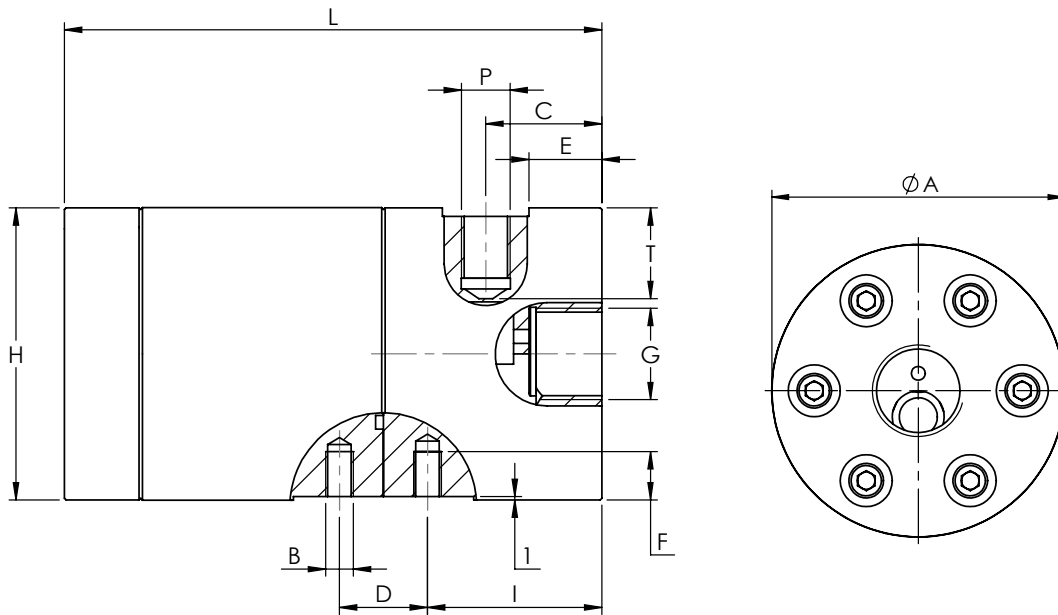

SRZ Type	Ø A	B	C	D	E	F	G <sup>5)</sup>	H	I	L	P <sup>6)</sup>	T <sup>6)</sup>
SRZ 40	85 mm [3.35 in]	M8	33.5 mm [1.32 in]	25 mm [0.98 in]	19 mm [0.75 in]	13 mm [0.51 in]	G ¾" ¾" NPT	81 mm [3.19 in]	50 mm [2.00 in]	155 mm [6.10 in]	E/D	26 mm [1.02 in]
SRZ 100	109 mm [4.29 in]	M10	53 mm [2.09 in]	44 mm [1.73 in]	23 mm [0.91 in]	18 mm [0.71 in]	G 1" 1" NPT	106 mm [4.17 in]	65 mm [2.56 in]	221 mm [8.70 in]	E/D	30 mm [1.18 in]
SRZ 400	134 mm [5.28 in]	M12	60 mm [2.36 in]	80 mm [3,15 in]	30 mm [1.18 in]	16 mm [0,63 in]	G 1½" 1½" NPT	132 mm [5.20 in]	119 mm [4,69 in]	318 mm [12.52 in]	E/D	33 mm [1.30 in]

<sup>5)</sup> Others on request.

<sup>6)</sup> Only applies for single pickup holes of type „E“.

Attention: the total installation height is the result of the height (H) and the height of the electronics (dimensions in separate datasheet).

Ordering Code

					<b>SRZ</b>	-	<b>XX</b>	-	<b>XX</b>	-	<b>X</b>	-	<b>X</b>	
<b>Measuring Range</b>							40							
0.4 - 40.0 l/min							100							
1.0 - 100 l/min							400							
4.0 - 400 l/min														
<b>Meter Attributes</b>														
<i>Housing</i>	<i>Spindle</i>	<i>Bearing</i>	<i>Bolts</i>	<i>Thread</i>										
1.4305 [AISI 303]	1.4122	ball bearing	ISO 4762	BSPP								KL		
1.4305 [AISI 303]	1.4122	ball bearing	ISO 4762	NPT								A1		
1.4404 [AISI 316L]	1.4122	ball bearing	AISI 316	BSPP								SK		
1.4404 [AISI 316L]	1.4122	ball bearing	AISI 316	NPT								SN		
<b>Sensor Ports</b>														
M14x1.5													E	
2xM14x1.5 (90° Phase Shift)													D	
<b>Sealing Options</b>														
FKM (Viton®)														V
PTFE (Teflon®)														T

Pressure Drop Curves

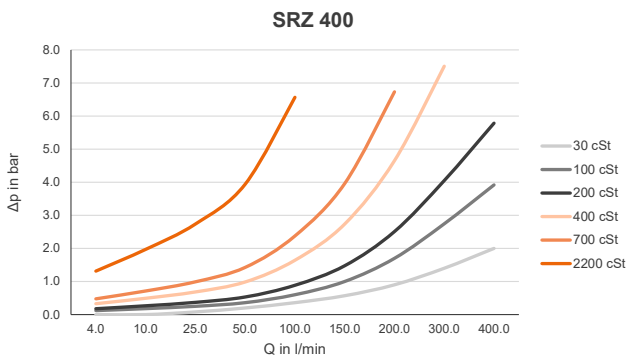
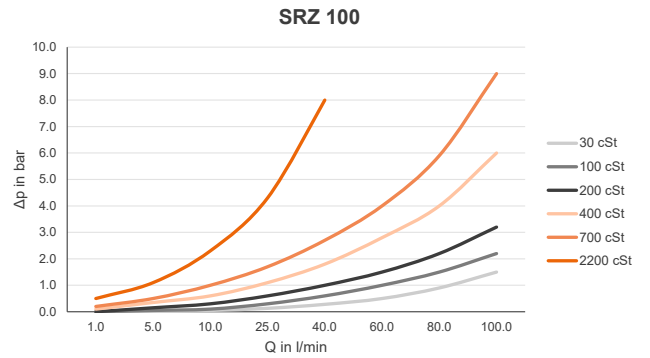
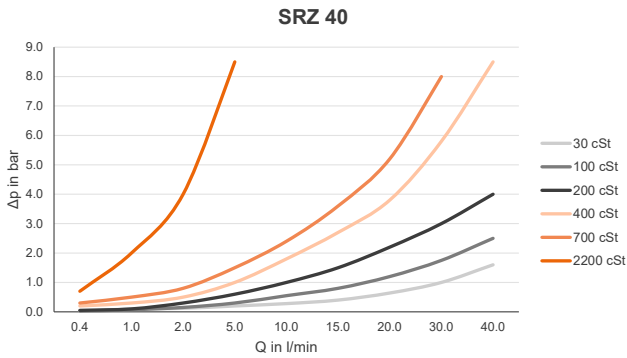

## Calibration

In-house calibration is performed on volumetric calibration rigs or at the wishes of the customer in our DAkkS calibration laboratory.

The KEM calibration lab uses a high-precision load cell system. With an accuracy of 0.05 % for the mass and 0.1 % for the volume of flowing liquids, we occupy a leading position worldwide. The German Accreditation Body (DAkkS) has accredited the laboratory with engineers, processes and measuring equipment in accordance with the international standard DIN EN ISO/IEC 17025:2018.

The KEM calibration certificate not only verifies the accuracy of a flow meter, but also guarantees its traceability to national standards as well as ensuring all requirements according to international quality standards are met.

The calibrations are performed with different hydrocarbons. This ensures the optimum simulation of changing operating conditions in density and viscosity even when temperatures change. This way the primary viscosity for the use of the flow meter can be specifically taken into account when viscosity fluctuations occur in a customised application.

The calibration result is the specified calibration factor (K-factor) in pulses per litre. This K-factor accordingly applies only at a certain flow velocity or a certain flow rate.

The calibration factor varies only very slightly at different volume flow rates. The individual measuring points provide the calibration curve of the flow meter from which the average K-factor is determined. The average calibration factor applies to the entire measuring range.

The linearity error specification (percentage deviation) refers to the average K-factor. To further increase the measurement accuracy in onsite use, the specific K-factors can be used to calculate the flow rate. For this, KEM also supplies optional special electronics.

## Calculation of volume flow

The flow is directly dependent on the measured frequency and the associated calibration factor:

$$Q = \frac{f \cdot 60}{K} \text{ l/min}$$

- Q = Volume Flow
- f = Measuring frequency
- K = Specific K-Factor

## Calibration protocol

Example: SRZ 40 KL

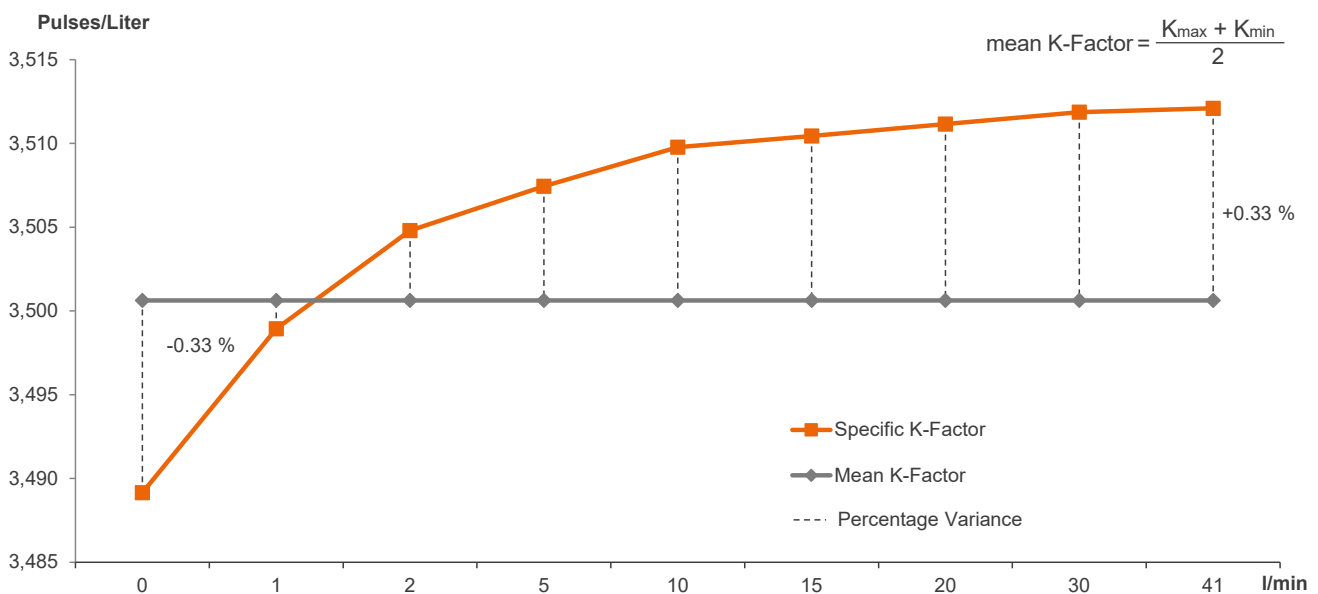



Küppers Elektromechanik GmbH

[www.kem-kueppers.com](http://www.kem-kueppers.com)

[info@kem-kueppers.com](mailto:info@kem-kueppers.com)

### KEM Headquarters

Liebigstraße 5  
85757 Karlsfeld  
Germany

T. +49 8131 59391-0  
F. +49 8131 92604

[info@kem-kueppers.com](mailto:info@kem-kueppers.com)

### KEM Manufacturing Center

Wetzeller Straße 22  
93444 Bad Kötzing  
Germany

T. +49 9941 9423-0  
F. +49 9941 9423-23

[production@kem-kueppers.com](mailto:production@kem-kueppers.com)

### KEM Sales

Liebigstraße 5  
85757 Karlsfeld  
Germany

T. +49 8131 59391-100  
F. +49 8131 92604

[sales@kem-kueppers.com](mailto:sales@kem-kueppers.com)

### KEM Service & Repairs

Wetzeller Straße 22  
93444 Bad Kötzing  
Germany

T. +49 9941 9423-37  
F. +49 9941 9423-24

[service@kem-kueppers.com](mailto:service@kem-kueppers.com)

*More distributors & partners can be found at:  
[www.kem-kueppers.com](http://www.kem-kueppers.com)*